

# EPSON

SCARA ROBOT

*LS series*

MANIPULATOR MANUAL

Rev.5

EM132R2465F

MANIPULATOR MANUAL

LS series Rev.5

SCARA ROBOT

# *LS series Manipulator Manual*

Rev.5

Copyright © 2011–2013 SEIKO EPSON CORPORATION. All rights reserved.

## FOREWORD

Thank you for purchasing our robot products.

This manual contains the information necessary for the correct use of the manipulator.

Please carefully read this manual and other related manuals before installing the robot system.

Keep this manual handy for easy access at all times.

## WARRANTY

The Manipulator and its optional parts are shipped to our customers only after being subjected to the strictest quality controls, tests, and inspections to certify its compliance with our high performance standards.

Product malfunctions resulting from normal handling or operation will be repaired free of charge during the normal warranty period. (Please ask your Regional Sales Office for warranty period information.)

However, customers will be charged for repairs in the following cases (even if they occur during the warranty period):

1. Damage or malfunction caused by improper use which is not described in the manual, or careless use.
2. Malfunctions caused by customers' unauthorized disassembly.
3. Damage due to improper adjustments or unauthorized repair attempts.
4. Damage caused by natural disasters such as earthquake, flood, etc.

Warnings, Cautions, Usage:

1. If the Manipulator or associated equipment is used outside of the usage conditions and product specifications described in the manuals, this warranty is void.
2. If you do not follow the WARNINGS and CAUTIONS in this manual, we cannot be responsible for any malfunction or accident, even if the result is injury or death.
3. We cannot foresee all possible dangers and consequences. Therefore, this manual cannot warn the user of all possible hazards.



## TRADEMARKS

Microsoft, Windows, and Windows logo are either registered trademarks or trademarks of Microsoft Corporation in the United States and/or other countries. Other brand and product names are trademarks or registered trademarks of the respective holders.

## NOTICE

No part of this manual may be copied or reproduced without authorization.

The contents of this manual are subject to change without notice.

Please notify us if you should find any errors in this manual or if you have any comments regarding its contents.

## INQUIRIES

Contact the following service center for robot repairs, inspections or adjustments.

If service center information is not indicated below, please contact the supplier office for your region.

Please prepare the following items before you contact us.

- Your controller model and its serial number
- Your manipulator model and its serial number
- Software and its version in your robot system
- A description of the problem

## SERVICE CENTER

--

## MANUFACTURER

### **SEIKO EPSON CORPORATION**

Toyoshina Plant  
Factory Automation Systems Dept.  
6925 Toyoshina Tazawa,  
Azumino-shi, Nagano, 399-8285  
JAPAN  
TEL : +81-(0)263-72-1530  
FAX : +81-(0)263-72-1495

## SUPPLIERS

North & South America **EPSON AMERICA, INC.**  
Factory Automation/Robotics  
18300 Central Avenue  
Carson, CA 90746  
USA  
TEL : +1-562-290-5900  
FAX : +1-562-290-5999  
E-MAIL : info@robots.epson.com

Europe **EPSON DEUTSCHLAND GmbH**  
Factory Automation Division  
Otto-Hahn-Str.4  
D-40670 Meerbusch  
Germany  
TEL : +49-(0)-2159-538-1391  
FAX : +49-(0)-2159-538-3170  
E-MAIL : robot.infos@epson.de

China **EPSON China Co., Ltd**  
Factory Automation Division  
7F, Jinbao Building No. 89 Jinbao Street  
Dongcheng District, Beijing,  
China, 100005  
TEL : +86-(0)-10-8522-1199  
FAX : +86-(0)-10-8522-1120

Taiwan **EPSON Taiwan Technology & Trading Ltd.**  
Factory Automation Division  
14F, No.7, Song Ren Road, Taipei 110  
Taiwan, ROC  
TEL : +886-(0)-2-8786-6688  
FAX : +886-(0)-2-8786-6677

Southeast Asia  
India

**Epson Singapore Pte Ltd.**  
Factory Automation System  
1 HarbourFrontPlace, #03-02  
HarbourFront Tower one, Singapore  
098633  
TEL : +65-(0)-6586-5696  
FAX : +65-(0)-6271-3182

Korea

**EPSON Korea Co, Ltd.**  
Marketing Team (Robot Business)  
11F Milim Tower, 825-22  
Yeoksam-dong, Gangnam-gu, Seoul, 135-934  
Korea  
TEL : +82-(0)-2-3420-6692  
FAX : +82-(0)-2-558-4271

Japan

**EPSON SALES JAPAN CORPORATION**  
Factory Automation Systems Department  
Nishi-Shinjuku Mitsui Bldg.6-24-1  
Nishishinjuku. Shinjuku-ku. Tokyo. 160-8324  
JAPAN  
TEL : +81-(0)3-5321-4161

## For Customers in the European Union



The crossed out wheeled bin label that can be found on your product indicates that this product and incorporated batteries should not be disposed of via the normal household waste stream. To prevent possible harm to the environment or human health please separate this product and its batteries from other waste streams to ensure that it can be recycled in an environmentally sound manner. For more details on available collection facilities please contact your local government office or the retailer where you purchased this product. Use of the chemical symbols Pb, Cd or Hg indicates if these metals are used in the battery.

This information only applies to customers in the European Union, according to DIRECTIVE 2006/66/EC OF THE EUROPEAN PARLIAMENT AND OF THE COUNCIL OF 6 September 2006 on batteries and accumulators and waste batteries and accumulators and repealing Directive 91/157/EEC and legislation transposing and implementing it into the various national legal systems.

For other countries, please contact your local government to investigate the possibility of recycling your product.

The battery removal/replacement procedure is described in the following manuals:

Controller manual / Manipulator manual (Maintenance section)

## Before Reading This Manual

This section describes what you should know before reading this manual.

### Structure of Control System

The LS series Manipulators can be used with the following combinations of Controllers and software.

#### TYPE A:

Controller	Software
RC90	EPSON RC+ 5.0

		RC90 Controller Firmware Version
		Ver.3.0.*.*
EPSON RC+ 5.0	Before Ver.5.4.0	!!!
	Ver.5.4.1 or later	OK

**OK:** Compatible All functions of the EPSON RC+ 5.0 and the Controller are available.

**!!!:** Compatible Connection is OK. We recommend using EPSON RC+5.0 Ver. 5.4.1 or later. Controller firmware update cannot be executed.

#### TYPE B: Robot Controller RC90 with the following label attached.

Label	Controller	Software
	RC90	EPSON RC+ 7.0

		RC90 controller firmware
		Ver.7.0.2.0
EPSON RC+ 7.0	Before Ver.7.0.1	!!!
	Ver.7.0.2 or later	OK

**OK:** Compatible All functions of the EPSON RC+ 7.0 and the Controller are available.

**!!!:** Compatible Connection is OK. We recommend using EPSON RC+7.0 Ver. 7.0.2 or later.

## Turning ON/OFF Controller

When you see the instruction “Turn ON/OFF the Controller” in this manual, be sure to turn ON/OFF all the hardware components. For the Controller composition, refer to the table above.

## Shape of Motors

The shape of the motors used for the Manipulator that you are using may be different from the shape of the motors described in this manual because of the specifications.

## Setting by Using Software

This manual contains setting procedures by using software. They are marked with the following icon.

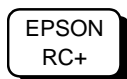

## Figures in this Manual

The figures of manipulators indicated in this manual are basically Standard-model Manipulator. Unless special instruction is provided, the specifications of Standard-model and Cleanroom-model are the same.

## Setup & Operation

<b>1. Safety</b>	<b>3</b>
1.1 Conventions.....	3
1.2 Design and Installation Safety.....	4
1.3 Operation Safety .....	5
1.4 Emergency Stop.....	6
1.5 Emergency Movement Without Drive Power .....	8
1.6 Manipulator Labels .....	9
<b>2. Specifications</b>	<b>11</b>
2.1 Features of LS series Manipulators .....	11
2.2 Model Number .....	12
2.3 Part Names and Outer Dimensions .....	13
2.3.1 Standard-Model .....	13
2.3.2 Cleanroom-Model .....	17
2.4 Specifications .....	21
2.5 How to Set the Model.....	23
<b>3. Environments and Installation</b>	<b>24</b>
3.1 Environmental Conditions .....	24
3.2 Base Table.....	25
3.3 Mounting Dimensions.....	26
3.3.1 LS3-401* .....	26
3.3.2 LS6-602* .....	28
3.4 Unpacking and Transportation .....	30
3.5 Installation Procedure.....	31
3.5.1 Standard-Model.....	31
3.5.2 Cleanroom-Model.....	32
3.6 Connecting the Cables.....	32
3.7 User Wires and Pneumatic Tubes.....	34
3.8 Relocation and Storage.....	35
3.8.1 Precautions for Relocation and Storage .....	35
3.8.2 Relocation.....	36
<b>4. Setting of End Effectors</b> .....	<b>37</b>
4.1 Attaching an End Effector.....	37
4.2 Attaching Cameras and Valves .....	39
4.3 Weight and Inertia Settings .....	40
4.3.1 Weight Setting .....	40
4.3.2 Inertia Setting .....	41
4.4 Precautions for Auto Acceleration/Deceleration of Joint #3.....	44

## TABLE OF CONTENTS

---

5. Motion Range.....	45
5.1 Motion Range Setting by Pulse Range (for All Joints).....	45
5.1.1 Max. Pulse Range of Joint #1 .....	46
5.1.2 Max. Pulse Range of Joint #2 .....	46
5.1.3 Max. Pulse Range of Joint #3 .....	47
5.1.4 Max. Pulse Range of Joint #4 .....	47
5.2 Motion Range Setting by Mechanical Stops.....	48
5.2.1 Setting the Mechanical Stops of Joints #1 and #2.....	49
5.2.2 Setting the Mechanical Stop of Joint #3 .....	51
5.3 Setting the Cartesian (Rectangular) Range in the XY Coordinate System of the Manipulator (for Joints #1 and #2).....	53
5.4 Standard Motion Range .....	53

## Maintenance

1. Safety Maintenance .....	57
2. General Maintenance .....	58
2.1 Schedule for Maintenance Inspection.....	58
2.2 Inspection Point.....	59
2.2.1 <b>Inspection</b> While the Power is OFF (Manipulator is not operating) .....	59
2.2.2 Inspection While the Power is ON (Manipulator is operating) .....	59
2.3 Greasing.....	60
2.4 Tightening Hexagon Socket Head Cap Bolts .....	61
2.5 Matching Origins .....	61
2.6 Layout of Maintenance Parts .....	62
3. Covers.....	63
3.1 Arm Top Cover .....	64
3.2 Arm Bottom Cover.....	64
3.3 Connector Plate .....	65
3.4 Connector Sub Plate.....	66
3.5 User Plate.....	66
4. Cable.....	67
4.1 <b>Replacing</b> Cable Unit .....	67
4.2 Wiring Diagrams.....	72
4.2.1 Signal Cable .....	72
4.2.2 Power Cable.....	74
4.2.3 User Cable .....	75
4.3 <b>Replacing</b> M/C Cable .....	76
5. Arm #1 .....	79
5.1 Replacing Joint #1 Motor .....	80
5.2 Replacing Joint #1 Reduction Gear Unit .....	83



<b>6. Arm #2.....</b>	<b>86</b>
6.1 Replacing Joint #2 Motor .....	87
6.2 Replacing Joint #2 Reduction Gear Unit.....	90
<b>7. Arm #3.....</b>	<b>94</b>
7.1 Replacing Joint #3 Motor .....	95
7.2 Replacing the Timing Belt .....	98
7.3 Replacing the Brake.....	101
<b>8. Arm #4.....</b>	<b>104</b>
8.1 Replacing Joint #4 Motor .....	105
8.2 Replacing the Timing Belt .....	108
8.2.1 U2 Belt.....	109
8.2.2 U1 Belt.....	114
8.3 Replacing the Brake (For LS6 series).....	117
<b>9. Bellows .....</b>	<b>119</b>
<b>10. Ball Screw Spline Unit .....</b>	<b>121</b>
10.1 Greasing the Ball Screw Spline Unit.....	121
10.1.1 Standard-model (S type) .....	122
10.1.2 Cleanroom-model.....	123
10.2 Replacing the Ball Screw Spline Unit.....	124
<b>11. Lithium Battery.....</b>	<b>127</b>
11.1 Replacing the Battery Unit (Lithium Battery).....	129
11.2 Replacing the Resolver Board.....	130
11.3 Replacing the Control Board .....	132
<b>12. LED Lamp .....</b>	<b>133</b>
<b>13. Calibration .....</b>	<b>134</b>
13.1 About Calibration.....	134
13.2 Calibration Procedure.....	135
13.3 Accurate Calibration of Joint #2.....	145
13.4 Calibration Procedure without using Calibration Wizard .....	147
<b>14. Maintenance Parts List .....</b>	<b>151</b>
14.1 LS3-401*.....	151
14.2 LS6-602*.....	152



# Setup & Operation

This volume contains information for setup and operation of the LS series Manipulators.

Please read this volume thoroughly before setting up and operating the Manipulators.





# 1. Safety

Installation and transportation of robots and robotic equipment shall be performed by qualified personnel and should conform to all national and local codes. Please read this manual and other related manuals before installing the robot system or before connecting cables.

Keep this manual handy for easy access at all times.

## 1.1 Conventions

Important safety considerations are indicated throughout the manual by the following symbols. Be sure to read the descriptions shown with each symbol.

 WARNING	This symbol indicates that a danger of possible serious injury or death exists if the associated instructions are not followed properly.
 WARNING	This symbol indicates that a danger of possible serious injury or death caused by electric shock exists if the associated instructions are not followed properly.
 CAUTION	This symbol indicates that a danger of possible harm to people or physical damage to equipment and facilities exists if the associated instructions are not followed properly.

## 1.2 Design and Installation Safety

Only trained personnel should design and install the robot system. Trained personnel are defined as those who have taken robot system training and maintenance training classes held by the manufacturer, dealer, or local representative company, or those who understand the manuals thoroughly and have the same knowledge and skill level as those who have completed the training courses.

To ensure safety, a safeguard must be installed for the robot system. For details on the safeguard, refer to the *Installation and Design Precautions* in the *Safety* chapter of the *EPSON RC+ User's Guide*.



The following items are safety precautions for design personnel:

 <p>WARNING</p>	<ul style="list-style-type: none"><li>■ Personnel who design and/or construct the robot system with this product must read the <i>Safety</i> chapter in the <i>EPSON RC+ User's Guide</i> to understand the safety requirements before designing and/or constructing the robot system. Designing and/or constructing the robot system without understanding the safety requirements is extremely hazardous, may result in serious bodily injury and/or severe equipment damage to the robot system, and may cause serious safety problems.</li><li>■ The Manipulator and the Controller must be used within the environmental conditions described in their respective manuals. This product has been designed and manufactured strictly for use in a normal indoor environment. Using the product in an environment that exceeds the specified environmental conditions may not only shorten the life cycle of the product but may also cause serious safety problems.</li><li>■ The robot system must be used within the installation requirements described in the manuals. Using the robot system outside of the installation requirements may not only shorten the life cycle of the product but also cause serious safety problems.</li></ul>
--	---

Further precautions for installation are mentioned in the chapter *Setup & Operation: 3. Environments and Installation*. Please read this chapter carefully to understand safe installation procedures before installing the robots and robotic equipment.

## 1.3 Operation Safety

The following items are safety precautions for qualified Operator personnel:

 WARNING	<ul style="list-style-type: none"> <li>■ Please carefully read the <i>Safety-related Requirements</i> in the <i>Safety</i> chapter of the <i>EPSON RC+ User's Guide</i> before operating the robot system. Operating the robot system without understanding the safety requirements is extremely hazardous and may result in serious bodily injury and/or severe equipment damage to the robot system.</li> <li>■ Do not enter the operating area of the Manipulator while the power to the robot system is turned ON. Entering the operating area with the power ON is extremely hazardous and may cause serious safety problems as the Manipulator may move even if it seems to be stopped.</li> <li>■ Before operating the robot system, make sure that no one is inside the safeguarded area. The robot system can be operated in the mode for teaching even when someone is inside the safeguarded area. The motion of the Manipulator is always in restricted (low speeds and low power) status to secure the safety of an operator. However, operating the robot system while someone is inside the safeguarded area is extremely hazardous and may result in serious safety problems in case that the Manipulator moves unexpectedly.</li> <li>■ Immediately press the Emergency Stop switch whenever the Manipulator moves abnormally while the robot system is operated. Continuing the operation while the Manipulator moves abnormally is extremely hazardous and may result in serious bodily injury and/or severe equipment damage to the robot system.</li> </ul>
 WARNING	<ul style="list-style-type: none"> <li>■ To shut off power to the robot system, pull out the power plug from the power source. Be sure to connect the AC power cable to a power receptacle. DO NOT connect it directly to a factory power source.</li> <li>■ Before performing any replacement procedure, turn OFF the Controller and related equipment, and then pull out the power plug from the power source. Performing any replacement procedure with the power ON is extremely hazardous and may result in electric shock and/or malfunction of the robot system.</li> <li>■ Do not insert or pull out the motor connectors while the power to the robot system is turned ON. Inserting or pulling out the motor connectors with the power ON is extremely hazardous and may result in serious bodily injury as the Manipulator may move abnormally, and also may result in electric shock and/or malfunction of the robot system.</li> </ul>
 CAUTION	<ul style="list-style-type: none"> <li>■ Whenever possible, only one person should operate the robot system. If it is necessary to operate the robot system with more than one person, ensure that all people involved communicate with each other as to what they are doing and take all necessary safety precautions.</li> </ul>

## 1.4 Emergency Stop

If the Manipulator moves abnormally during operation, immediately press the Emergency Stop switch. Stops the power supply to the motor, and the arm stops in the shortest distance with the dynamic brake and mechanical brake.

However, avoid pressing the Emergency Stop switch unnecessarily while the Manipulator is running normally. Otherwise, the Manipulator may hit the peripheral equipment since the operating trajectory until the robot system stops is different from that in normal operation. It may also reduce the life of the reduction gear unit by the shock, or reduce the life of the electromagnetic brake by worn friction plate.

To place the system in emergency mode during normal operation, press the Emergency Stop switch when the Manipulator is not moving.

Refer to the Controller manual for instructions on how to wire the Emergency Stop switch circuit.

Do not press the Emergency Stop switch unnecessarily while the Manipulator is operating. Pressing the switch during the operation makes the brakes work. This will shorten the life of the brakes due to the worn friction plates.

Normal brake life: About 2 years (when the brakes are used 100 times/day)

Before using the Emergency Stop switch, be aware of the followings.

- The Emergency Stop (E-STOP) switch should be used to stop the Manipulator only in case of emergencies.
- To stop the Manipulator operating the program except in emergency, use Pause (halt) or STOP (program stop) commands.  
Pause and STOP commands do not turn OFF the motors. Therefore, the brake does not function.
- For the Safeguard system, do not use the circuit for E-STOP.

For details of the Safeguard system, refer to the following manuals.

EPSON RC+ User's Guide

*2. Safety - Installation and Design Precautions - Safeguard System*

Safety and Installation

*2.6 Connection to EMERGENCY Connector*

To check brake problems, refer to the following manuals.

Manipulator Manual Maintenance

*2.2.2 Inspection While the Power is ON (Manipulator is operating)*

Safety and Installation

*5.2 Inspection Point - Inspection While the Power is ON  
(Manipulator is operating)*



**Free running distance in emergency**

The operating Manipulator cannot stop immediately after the Emergency Stop switch is pressed.

The free running time/angle/distance of the Manipulator are shown below. However, remember that the values vary depending on following conditions.

Weight of the end effector Weight of work piece Operating pose  
 Weight Speed Accel etc.

Conditions for Measurement

	LS3-401*	LS6-602*
Accel Setting	100	100
Speed Setting	100	100
Load [kg]	3	4
Weight Setting	3	4

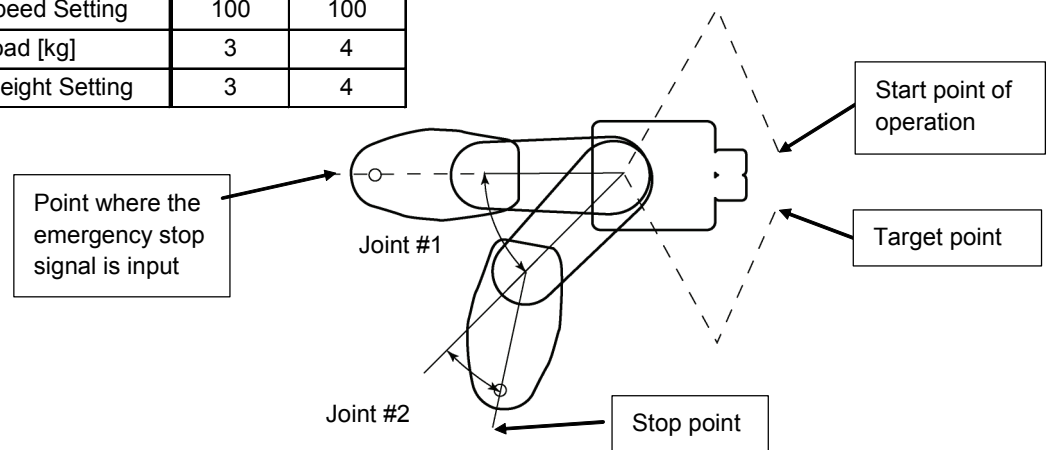

Controller		RC90	
		LS3-401*	LS6-602*
Free running time	Joint #1 + Joint #2 [sec.]	0.4	0.7
	Joint #3 [sec.]	0.1	0.2
Free running angle	Joint #1 [deg.]	110	100
	Joint #2 [deg.]	20	45
	Joint #1 + Joint #2 [deg.]	130	130
Free running distance	Joint #3 [mm]	20	50

## 1.5 Emergency Movement Without Drive Power

When the system is placed in emergency mode, push the arm or joint of the Manipulator by hand as shown below:

Arm #1 .....Push the arm by hand.

Arm #2 .....Push the arm by hand.

Joint #3 ..... The joint cannot be moved up/down by hand until the solenoid brake applied to the joint has been released. Move the joint up/down while pressing the brake release switch.

Joint #4 LS3: Rotate the shaft by hand.

LS6: The shaft cannot be rotated by hand until the solenoid brake applied to the shaft has been released. Move the shaft while pressing the brake release switch.

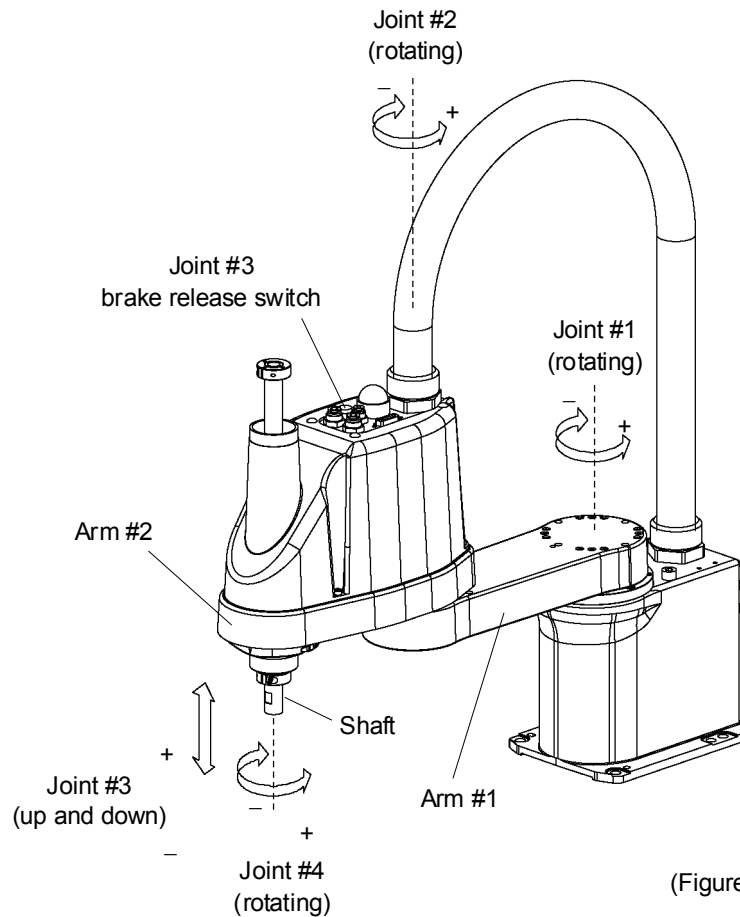

(Figure: LS3-401S)



LS3: The brake release switch affects only Joint #3. When the brake release switch is pressed in emergency mode, the brake for Joint #3 is released.

Be careful of the shaft while the brake release switch is pressed because the shaft may be lowered by the weight of an end effector.

LS6: The brake release switch affects both Joints #3 and #4. When the brake release switch is pressed in emergency mode, the brake for both Joints #3 and #4 are released simultaneously.





Be careful of the shaft falling and rotating while the brake release switch is pressed because the shaft may be lowered by the weight of an end effector.

## 1.6 Manipulator Labels

The following labels are attached near the locations of the Manipulator where specific dangers exist.

Be sure to comply with descriptions and warnings on the labels to operate and maintain the Manipulator safely.

Do not tear, damage, or remove the labels. Use meticulous care when handling those parts or units to which the following labels are attached as well as the nearby areas:

	Labels	NOTE
A		Before loosening the base mounting screws, hold the arm and secure it tightly with a band to prevent hands or fingers from being caught in the Manipulator.
B		Do not enter the operation area while the Manipulator is moving. The robot arm may collide against the operator. This is extremely hazardous and may result in serious safety problems.
C		Hazardous voltage exists while the Manipulator is ON. To avoid electric shock, do not touch any internal electric parts.
D		You can catch your hand or fingers between the shaft and cover when bringing your hand close to moving parts. * Manipulators with bellows do not have this label for no danger of your hand or fingers being caught.
E	<p>MODEL : LS3-401S  SERIAL NO. : *L300000001*  MANUFACTURED : 03/2011  WEIGHT : 14kg MAX PAYLOAD : 3kg  MOTOR POWER  AXIS1 : 200W AXIS2 : 100W  AXIS3 : 100W AXIS4 : 100W  SEIKO EPSON CORPORATION  MADE IN CHINA.</p> 	

LS3-401\*

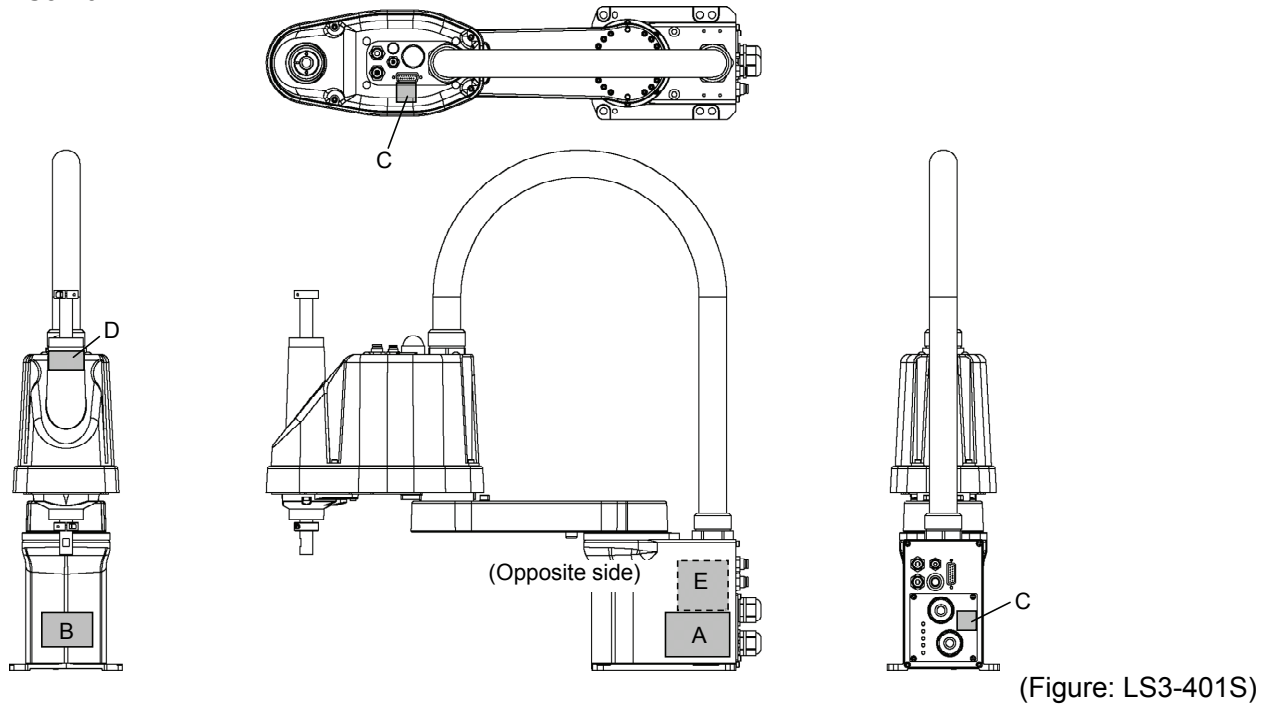

LS6-602\*

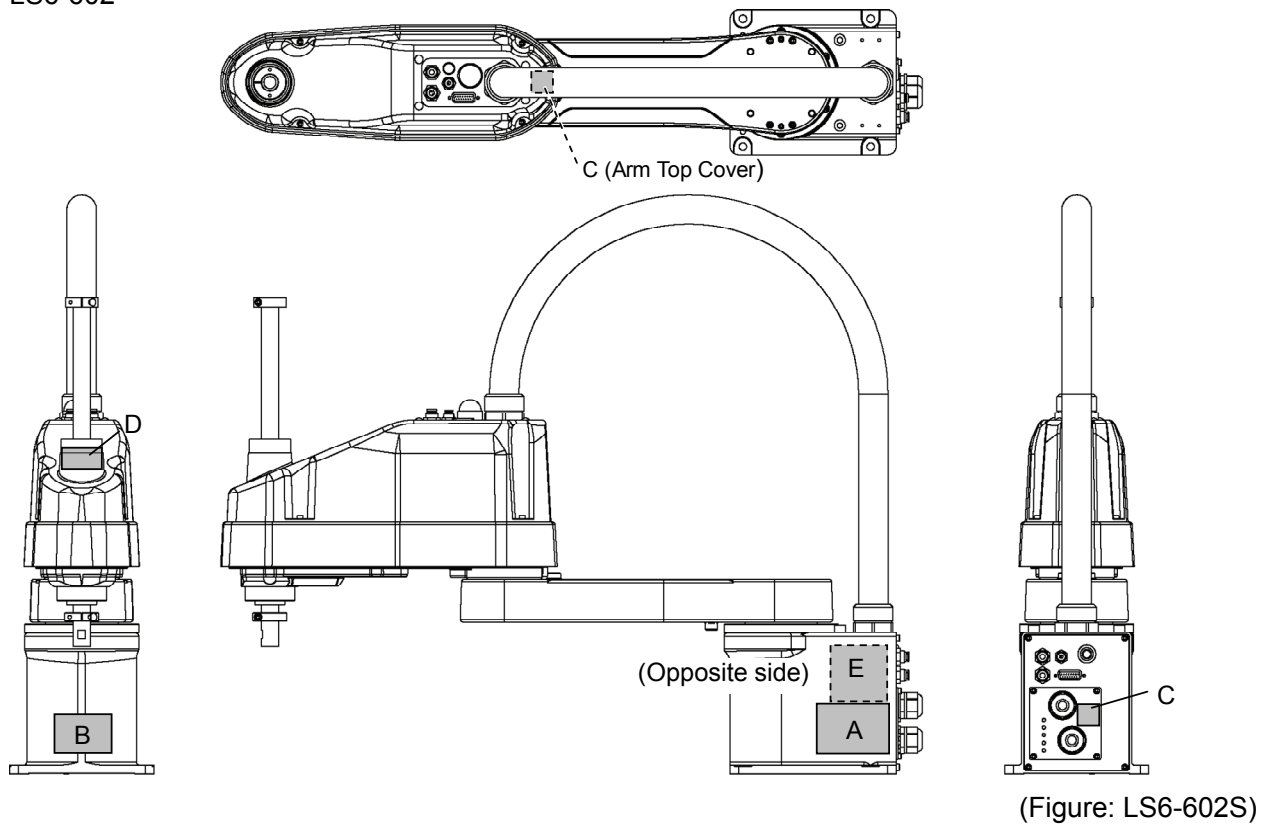

## 2. Specifications

### 2.1 Features of LS series Manipulators

The LS3 series Manipulators are advanced manipulators pursuing high speed and high cost-performance.

The features of the LS series Manipulators are as follows:

#### Resolver for the Position Detector

It includes no electrical components; therefore it has high resistance to environment and hardly breaks down.

It mounts the resolver board and battery inside the manipulator; therefore the calibration is not required when you disconnect the M/C cable.

#### Large Capacity

It supports the U-axis allowable moment up to  $0.12 \text{ kg}\cdot\text{m}^2$  (LS6)  
/  $0.05 \text{ kg}\cdot\text{m}^2$  (LS3).

It stably handles large loads by optimized control based on the each load.

#### Tact Time Improvement by High-speed Motion

It improves the tact time of long-range movements by readjusting the highest speed. (LS3)

It improves the tact time of delicate movements by *acceleration/deceleration speed optimized for each payload and stop short technology*.

## 2.2 Model Number

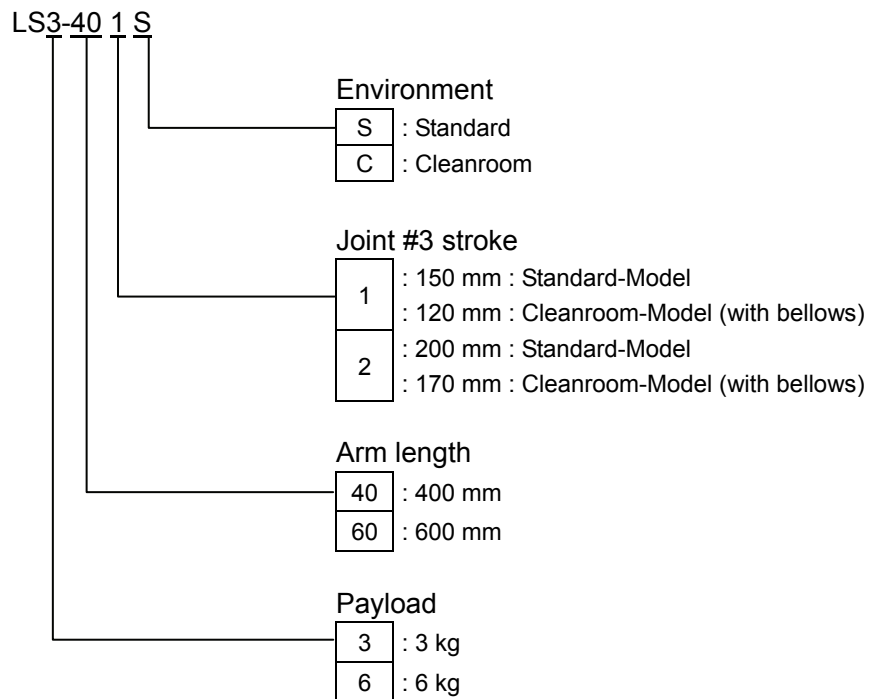

### Environment

#### *Cleanroom-model*

This model has additional features that reduce dust emitted by the Manipulator to enable use in clean room environments.

For details on the specifications, refer to *Setup & Operation: 2.4 Specifications*.

### Models

Payload	Arm length	Environment	Joint #3 stroke	Model Number
3 kg	400 mm	Standard	150 mm	LS3-401S
		Cleanroom	120 mm	LS3-401C
6 kg	600 mm	Standard	200 mm	LS6-602S
		Cleanroom	170 mm	LS6-602C

## 2.3 Part Names and Outer Dimensions

### 2.3.1 LS3-401\*

Standard-Model LS3-401S

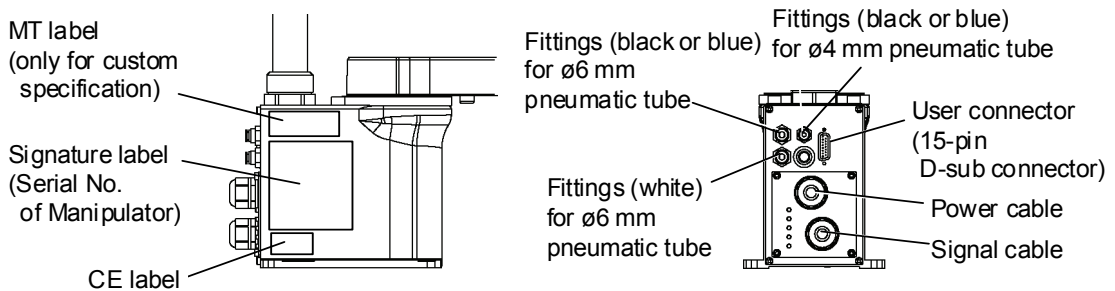
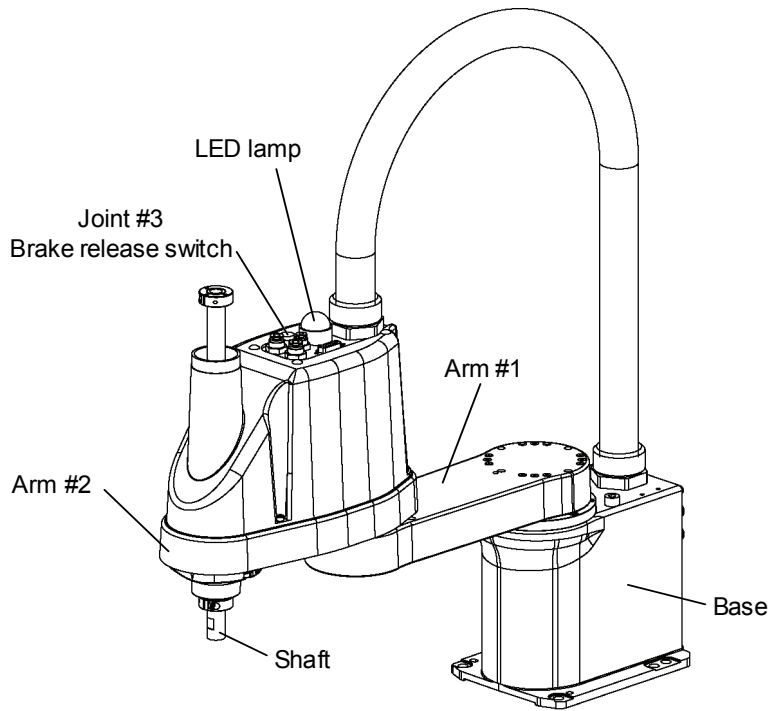

NOTE



- The brake release switch affects only Joint #3. When the brake release switch is pressed in emergency mode, the brake for Joint #3 is released.
- While the LED lamp is on, the current is being applied to the manipulator. Performing any work with the power ON is extremely hazardous and it may result in electric shock and/or improper function of the robot system. Make sure to turn OFF the controller power before the maintenance work.

Standard-Model LS3-401S

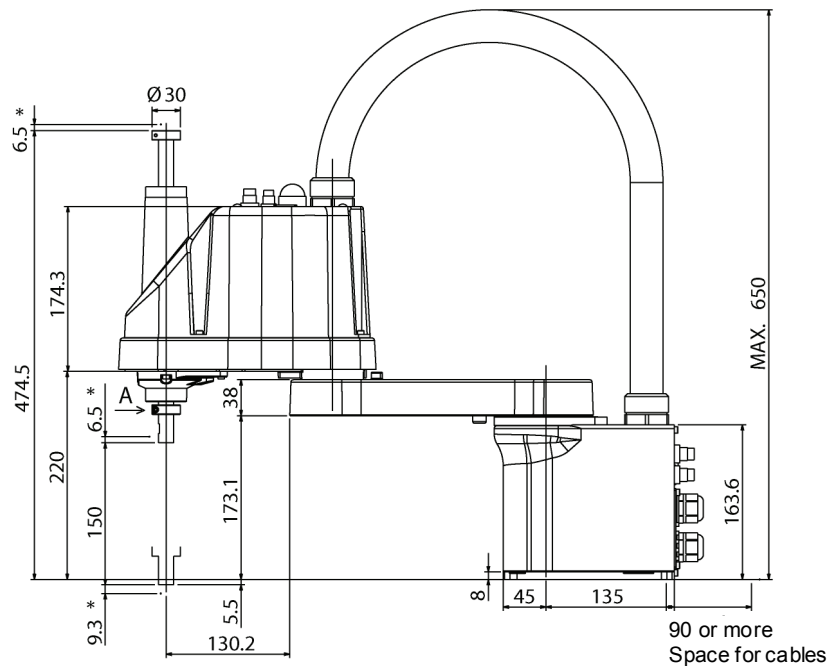
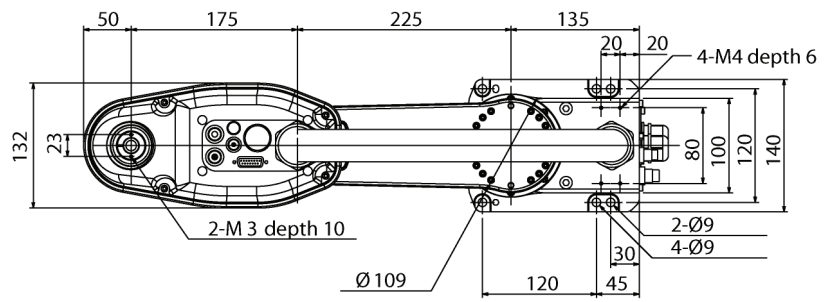

(\* indicates the stroke margin by mechanical stop.

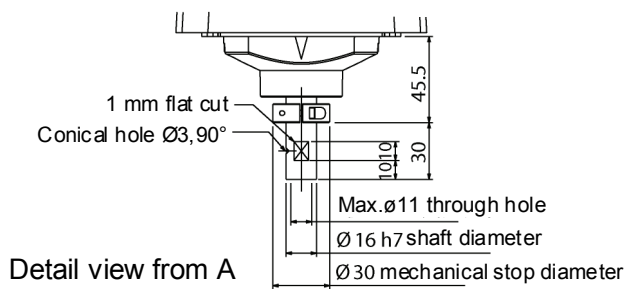
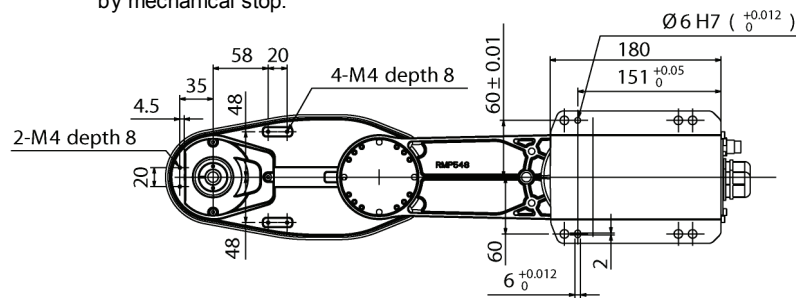



Cleanroom-Model LS3-401C

The following figures show the additional parts and specifications for Cleanroom-model when compared with the Standard-model in appearance.

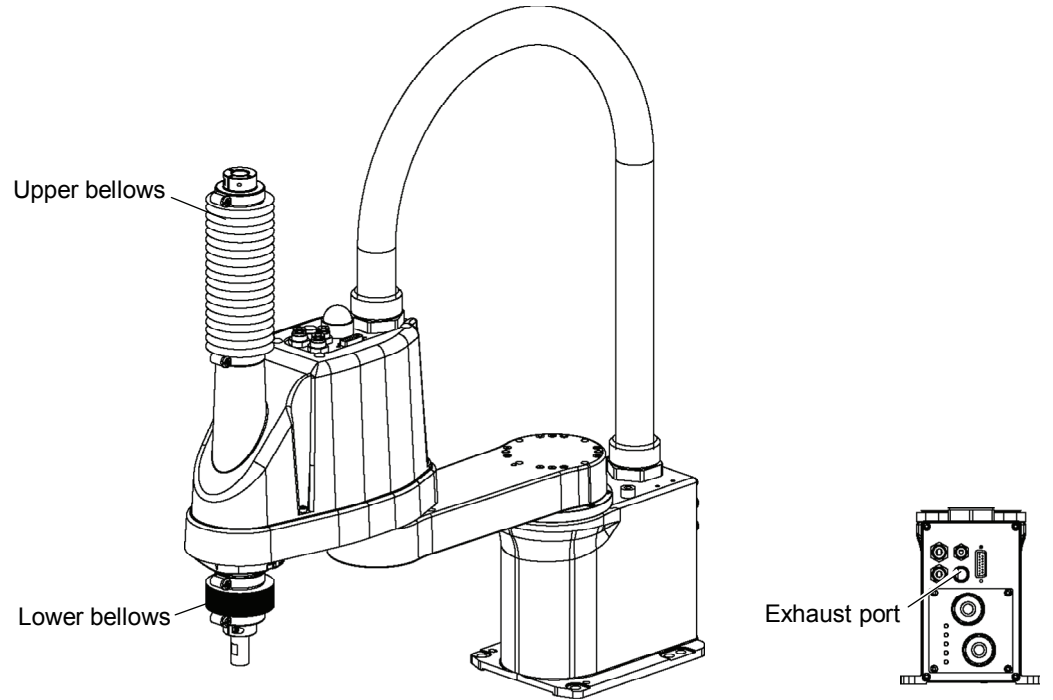

Cleanroom-Model LS3-401C

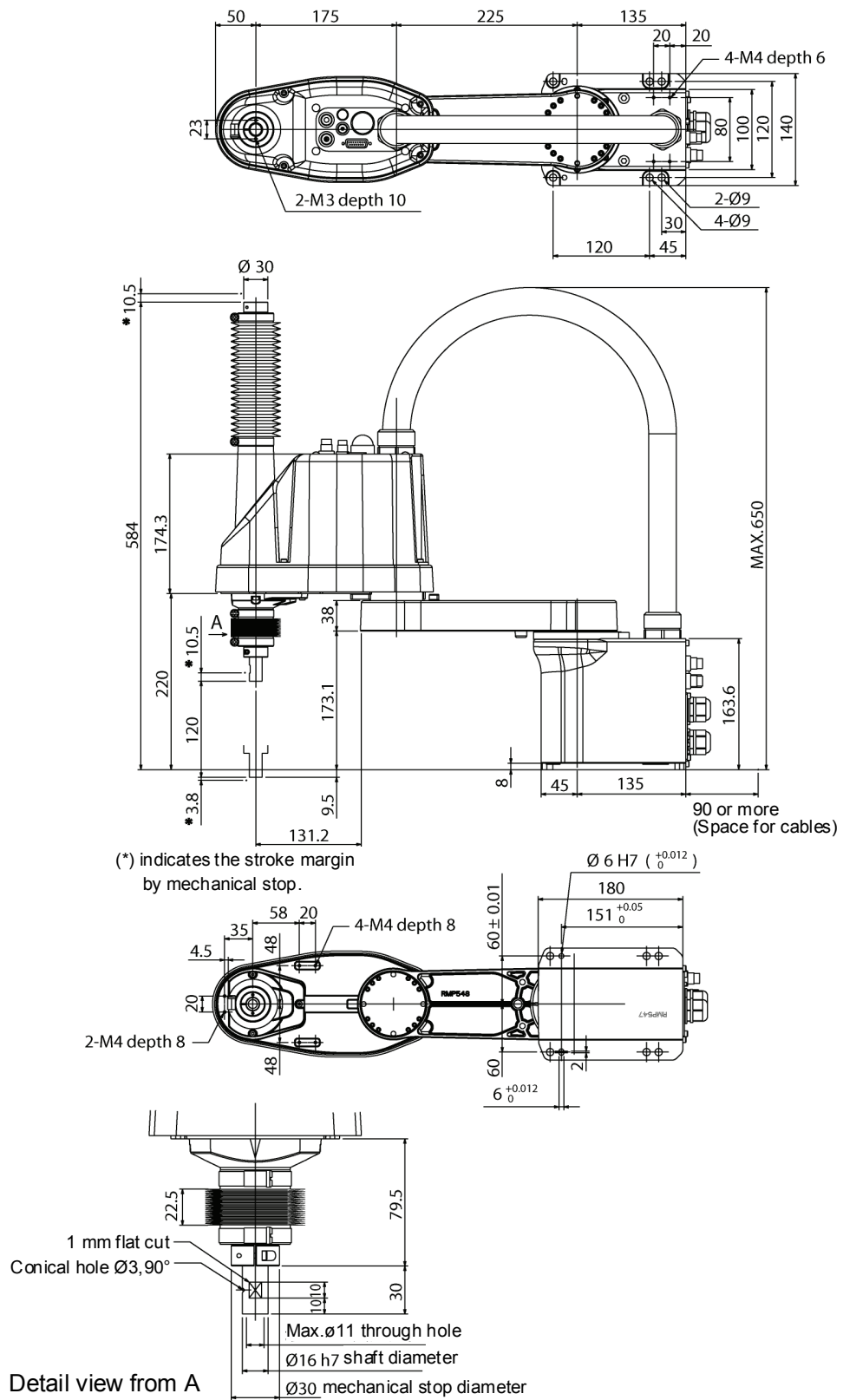

2.3.2 LS6-602\*

Standard-Model LS6-602S

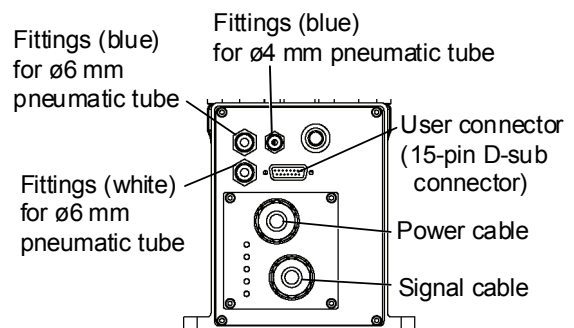
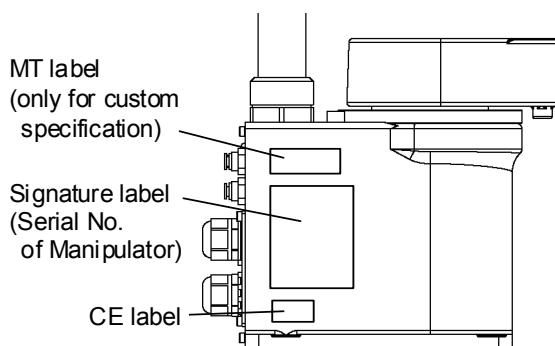
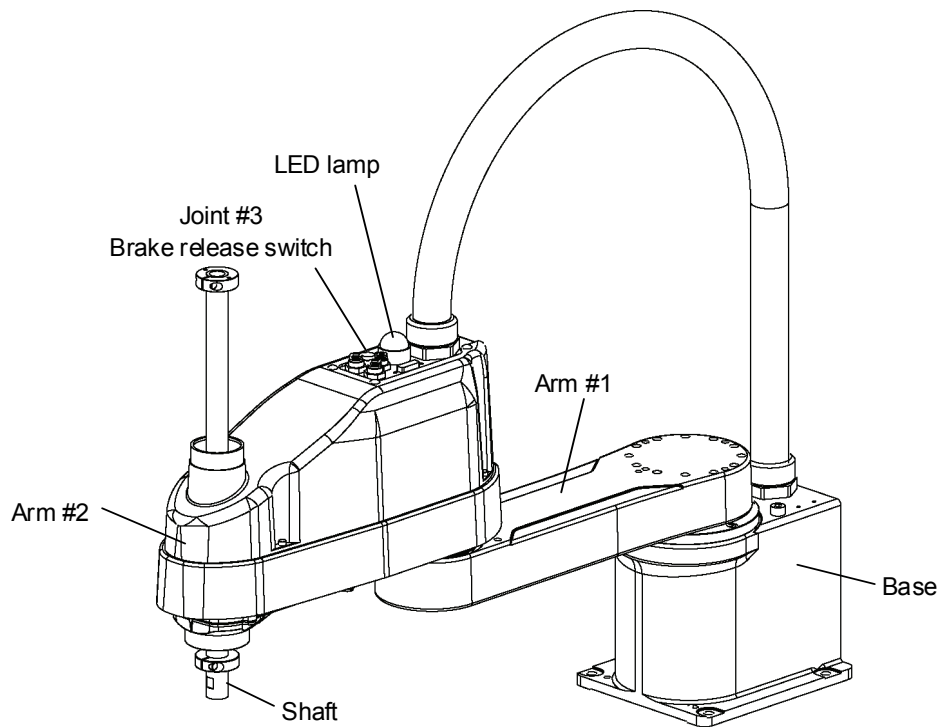

NOTE  

- The brake release switch affects both Joints #3 and #4. When the brake release switch is pressed in emergency mode, the brakes for both Joint #3 and Joint #4 are released simultaneously.
- While the LED lamp is on, the current is being applied to the manipulator. Performing any work with the power ON is extremely hazardous and it may result in electric shock and/or improper function of the robot system. Make sure to turn OFF the controller power before the maintenance work.

Standard-Model LS6-602S

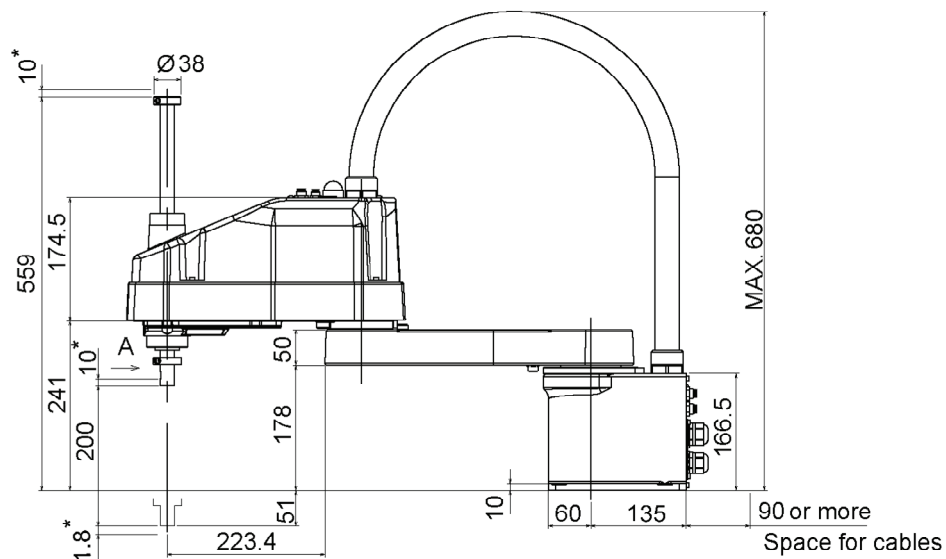
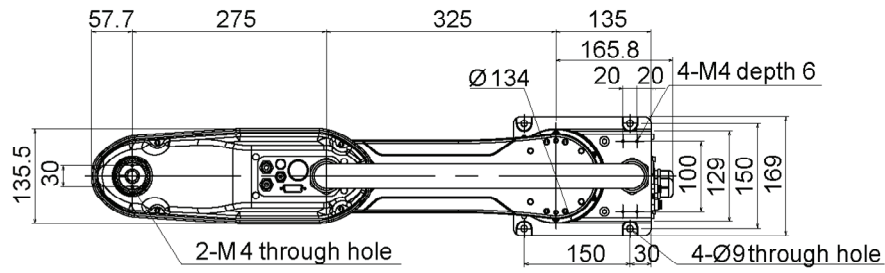

(\* ) indicates the stroke margin by mechanical stop.

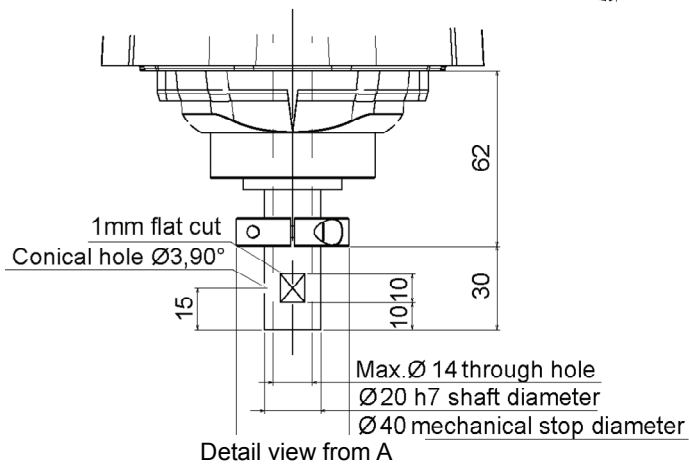
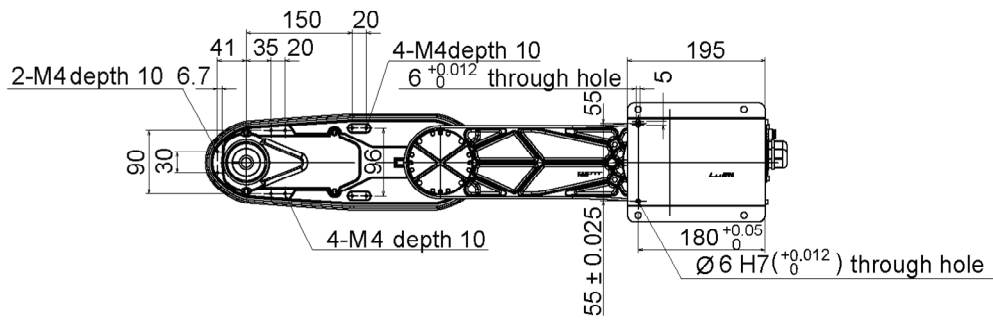

Detail view from A

Cleanroom-Model LS6-602C

The following figures show the additional parts and specifications for Cleanroom-model when compared with the Standard-model in appearance.

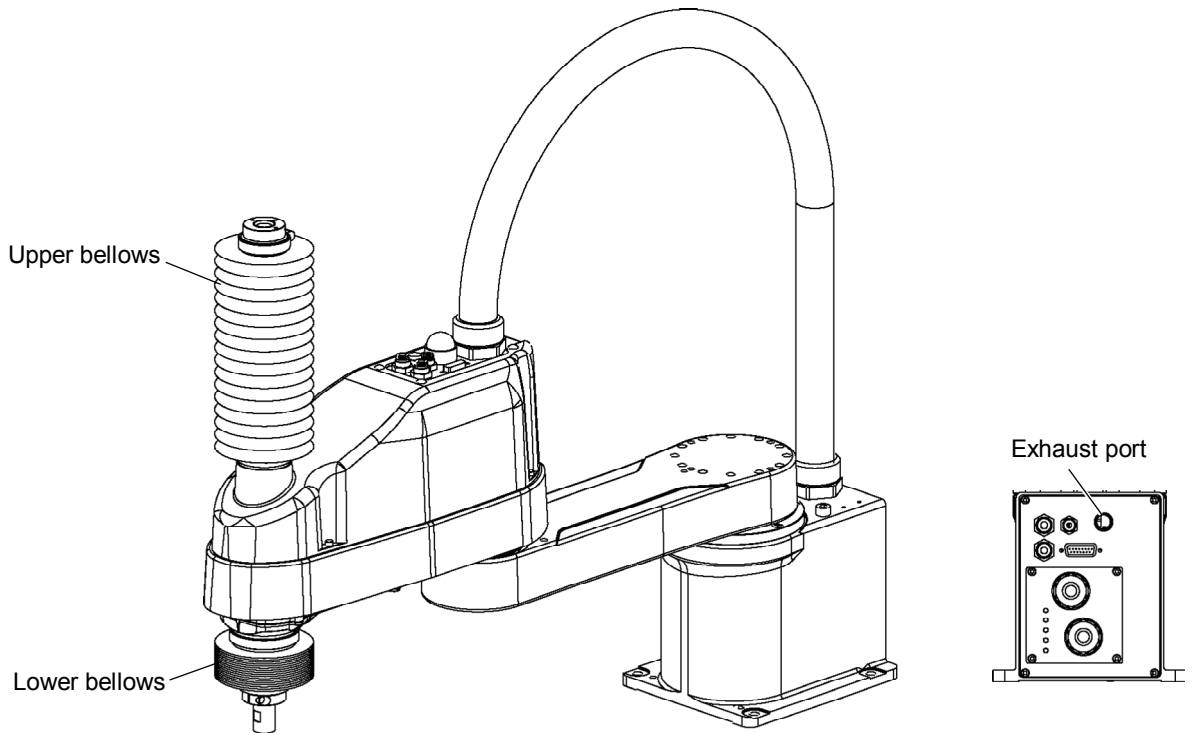

Cleanroom-Model LS6-602C

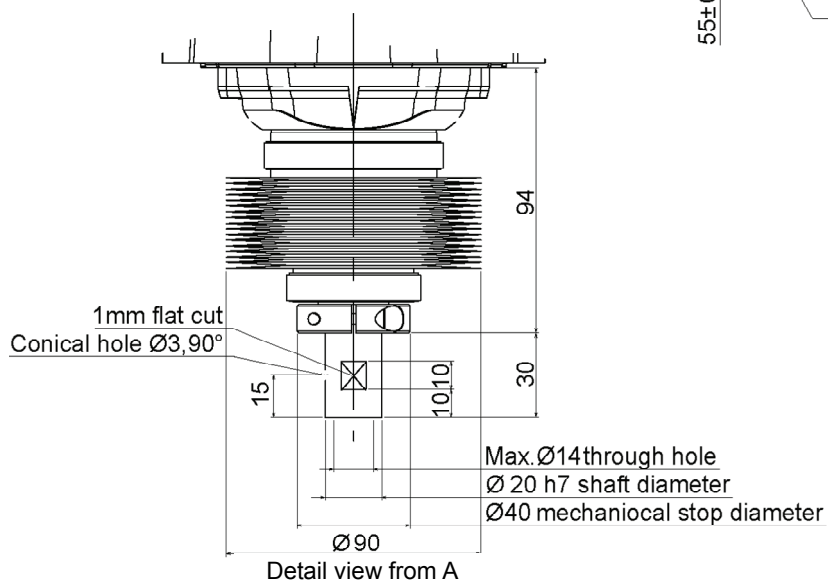
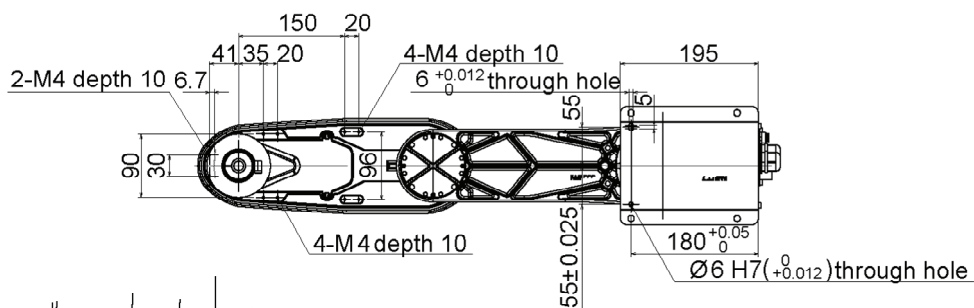
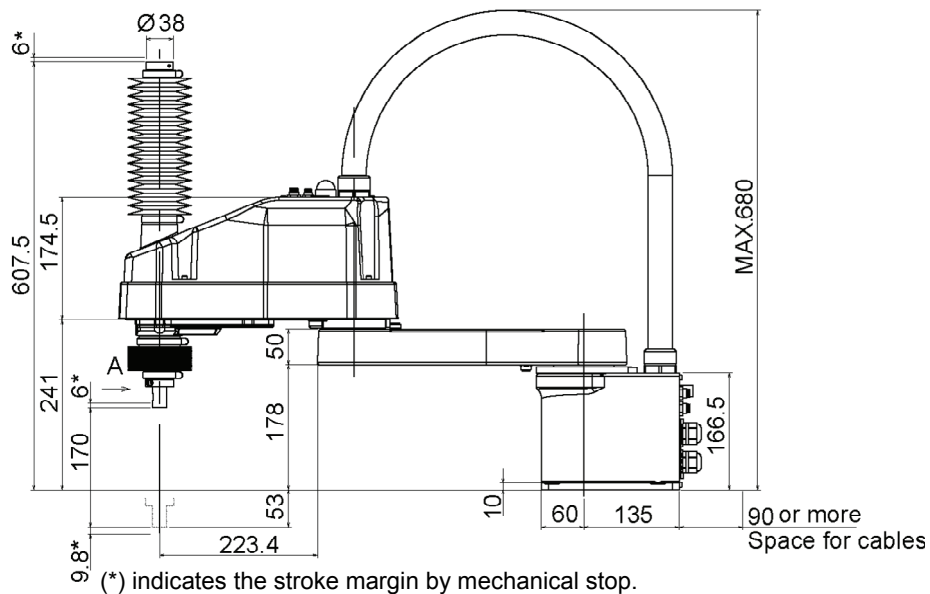
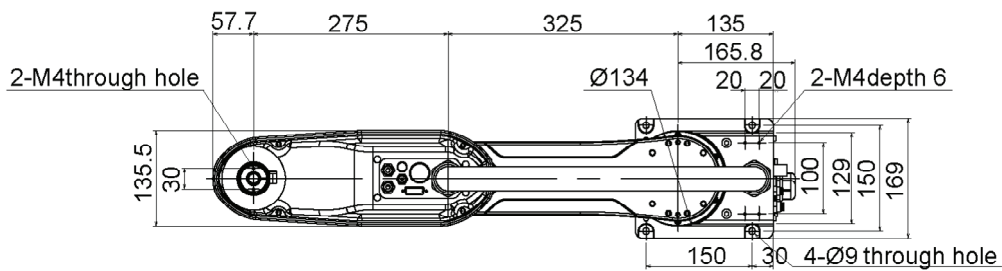

## 2.4 Specifications

Item		LS3-401*	LS6-602*
Arm length	Arm #1, #2	400 mm	600 mm
	Arm #1	225 mm	325 mm
	Arm #2	175 mm	275 mm
Max. operating speed *1	Joints #1, #2	6000 mm/s	6800 mm/s
	Joint #3	1100 mm/s	
	Joint #4	2600 deg./s	2000 deg/s
Repeatability	Joints #1, #2	± 0.01 mm	± 0.02 mm
	Joint #3	± 0.01 mm	
	Joint #4	± 0.01 deg.	
Payload (Load)	Rated	1 kg	2 kg
	Max.	3 kg	6 kg
Joint #4 allowable moment of inertia *2	Rated	0.005 kg·m <sup>2</sup>	0.01 kg·m <sup>2</sup>
	Max.	0.05 kg·m <sup>2</sup>	0.12 kg·m <sup>2</sup>
Resolution	Joints #1	0.000439 deg./pulse	0.000275 deg/pulse
	Joint #2	0.000439 deg./pulse	
	Joint #3	0.000799 mm/pulse	0.000814 mm/pulse
	Joint #4	0.001927 deg./pulse	0.001465 deg/pulse
Hand	Shaft diameter	ø 16 mm	ø 20 mm
	Through hole	ø 11 mm	ø 14 mm
Mounting hole		120 × 120 mm / 135 × 120 mm (Free choice of either hole.)	150 × 150 mm
		4-M8	
Weight (cables not included)		14 kg : 31 lb	17 kg : 37.5 lb
Driving method	All joints	AC servo motor	
Motor energy consumption	Joint #1	200 W	
	Joint #2	100 W	200 W
	Joint #3	100 W	
	Joint #4	100 W	
Option	Installation environment	Cleanroom *3	
Joint #3 down force		100 N	
Installed wire for customer use		15 (15 pin: D-sub)	
Installed pneumatic tube for customer use		2 pneumatic tubes (ø6 mm) : 0.59 Mpa (6 kgf/cm <sup>2</sup> : 86 psi)	
		1 pneumatic tubes (ø4 mm) : 0.59 Mpa (6 kgf/cm <sup>2</sup> : 86 psi)	
Environmental requirements	Ambient Temp.	5 to 40 degrees C (with minimum temperature variation)	
	Ambient relative humidity	10 to 80% (no condensation)	
Noise level *4		L <sub>Aeq</sub> = 70 dB (A)	
Applicable Controller		RC90	
Assignable Value ( ) Default values	SPEED	1 to (5) to 100	
	ACCEL *5	1 to (10) to 120	
	SPEEDS	1 to (50) to 2000	
	ACCELS	1 to (200) to 25000	
	FINE	0 to (1250) to 65000	
	WEIGHT	0,175 to (1,175) to 3,175	0,275 to (2,275) to 6,275
MTBF		3 years	
Safety standard		ANSI/RIA R15.06-1999	
		NFPA 79 (2007 Edition)	
		CSA/CAN Z434-03 (February 2003)	
		CE Marking – Machinery, Low Voltage, EMC Directive	

Item		LS3-401S	LS3-401C	LS6-602S	LS6-602C
Max. motion range	Joint #1	± 132 deg			
	Joint #2	± 141 deg		± 150 deg	
	Joint #3	150 mm	120 mm	200 mm	170 mm
	Joint #4	± 360 deg			
Max. pulse range	Joint #1	- 95574~505174 pulse		- 152918~808278 pulse	
	Joint #2	± 320854 pulse		± 341334 pulse	
	Joint #3	-187734~0 pulse	-150187~0 pulse	-245760~0 pulse	-208896~0 pulse
	Joint #4	± 186778 pulse		± 245760 pulse	

\*1: In the case of PTP command.

Maximum operating speed for CP command is 2000 mm/s on horizontal plane.

\*2: In the case where the center of gravity is at the center of Joint #4.

If the center of gravity is not at the center of Joint #4, set the parameter using Inertia command.

\*3: The exhaust system in the Cleanroom-model Manipulator draws air from the base interior and arm cover interior together.

A crack or other opening in the base unit can cause loss of negative air pressure in the outer part of the arm, which can cause increased dust emission.

Do not remove the maintenance cover on the front of the base.

Seal the exhaust port and the exhaust tube with vinyl tape so that the joint is airtight.

If the exhaust flow is not sufficient, dust particle emission may exceed the specified maximum level.

Cleanliness level : Class ISO 4 (ISO14644-1)

Exhaust System : Exhaust port diameter : Inner diameter: ø12 mm / Outer diameter: ø16 mm

Exhaust tube : Polyurethane tube

Outer diameter: ø12 mm (Inner diameter: ø8 mm) or

Inner diameter ø16mm

Recommended exhaust flow rate : approx. 1000 cm<sup>3</sup>/s (Normal)

\*4: Conditions of Manipulator during measurement as follows:

Operating conditions : Under rated load, 4-joints simultaneous motion, maximum speed, maximum acceleration, and duty 50%.

Measurement point : In front of the Manipulator, 1000 mm apart from the motion range, 50 mm above the base-installed surface.

\*5: In general use, Accel setting 100 is the optimum setting that maintains the balance of acceleration and vibration when positioning.

However, you may require an operation with high acceleration to shorten the cycle time by decreasing the vibration at positioning. In this case, set Accel to larger than 100.

If you specify a larger Accel value, the frequency of the overload error and over heat may rise during continuous operation. The use of large Accel setting is recommended only for necessary motions.



## 2.5 How to Set the Model

The Manipulator model for your system has been set before shipment from the factory. It is normally not required to change the model when you receive your system.



CAUTION

- When you need to change the setting of the Manipulator model, be sure to set the Manipulator model properly. Improper setting of the Manipulator model may result in abnormal or no operation of the Manipulator and/or cause safety problems.

NOTE



If an MT label is attached to the rear of a Manipulator, the Manipulator has custom specifications. The custom specifications may require a different configuration procedure; check the custom specifications number described on the MT label and contact us when necessary.

The Manipulator model can be set from software.

Refer to the chapter *Robot Configuration* in the *EPSON RC+ User's Guide*.

## 3. Environments and Installation

### 3.1 Environmental Conditions

A suitable environment is necessary for the robot system to function properly and safely. Be sure to install the robot system in an environment that meets the following conditions:

Item	Conditions
Ambient temperature *	5 to 40°C (with minimum temperature variation)
Ambient relative humidity	10 to 80% (no condensation)
First transient burst noise	2 kV or less
Electrostatic noise	6 kV or less
Environment	<ul style="list-style-type: none"> <li>· Install indoors.</li> <li>· Keep away from direct sunlight.</li> <li>· Keep away from dust, oily smoke, salinity, metal powder or other contaminants.</li> <li>· Keep away from flammable or corrosive solvents and gases.</li> <li>· Keep away from water.</li> <li>· Keep away from shocks or vibrations.</li> <li>· Keep away from sources of electric noise.</li> </ul>

NOTE



Manipulators are not suitable for operation in harsh environments such as painting areas, etc. When using Manipulators in inadequate environments that do not meet the above conditions, please contact us.

\* The ambient temperature conditions are for the Manipulators only. For the Controller the Manipulators are connected to, refer to the Controller manual.

#### Special Environmental Conditions

The surface of the Manipulator has general oil resistance. However, if your requirements specify that the Manipulator must withstand certain kinds of oil, please consult your distributor.

Rapid change in temperature and humidity can cause condensation inside the Manipulator.

If your requirements specify that the Manipulator handles food, please consult your distributor to check whether the Manipulator gives damage to the food or not.

The Manipulator cannot be used in corrosive environments where acid or alkaline is used. In a salty environment where the rust is likely to gather, the Manipulator is susceptible to rust.

 WARNING	<ul style="list-style-type: none"> <li>■ Use an earth leakage breaker on the AC power cable of the Controller to avoid the electric shock and circuit breakdown caused by an unexpected water leak. Prepare the earth leakage brake that pertains the controller you are using. For details, refer to the controller manual.</li> </ul>
-------------	---

 CAUTION	<ul style="list-style-type: none"> <li>■ When cleaning the Manipulator, do not rub it strongly with alcohol or benzene. It may lose luster on the coated face.</li> </ul>
-------------	---

## 3.2 Base Table

A base table for anchoring the Manipulator is not supplied. Please make or obtain the base table for your Manipulator. The shape and size of the base table differs depending on the use of the robot system. For your reference, we list some Manipulator table requirements here.

The torque and reaction force produced by the movement of the Manipulator are as follows:

	LS3-401*	LS6-602*
Max. Reaction torque on the horizontal plate	250 Nm	350 Nm
Max. Horizontal reaction force	1000 N	1500 N
Max. Vertical reaction force	1000 N	1500 N

The threaded holes required for mounting the Manipulator base are M8. Use mounting bolts with specifications conforming to ISO898-1 property class: 10.9 or 12.9. For dimensions, refer to *Setup & Operation: 3.3 Mounting Dimensions*.

The plate for the Manipulator mounting face should be 20 mm thick or more and made of steel to reduce vibration. The surface roughness of the steel plate should be 25 µm or less.

The table must be secured on the floor or wall to prevent it from moving.

The Manipulator must be installed horizontally.

When using a leveler to adjust the height of the base table, use a screw with M16 diameter or more.

If you are passing cables through the holes on the base table, see the figures below.

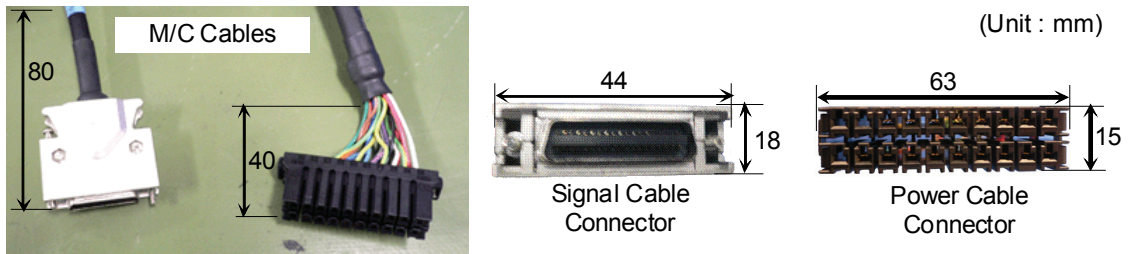

Do not remove the M/C cables from the Manipulator.



For environmental conditions regarding space when placing the Controller on the base table, refer to the *Controller manual*.



- To ensure safety, a safeguard must be installed for the robot system. For details on the safeguard, refer to the *EPSON RC+ User's Guide*.

### 3.3 Mounting Dimensions

The maximum space described in figures shows that the radius of the end effector is 60 mm or less. If the radius of the end effector exceeds 60 mm, define the radius as the distance to the outer edge of maximum space.

If a camera or solenoid valve extends outside of the arm, set the maximum range including the space that they may reach.

Be sure to allow for the following extra spaces in addition to the space required for mounting the Manipulator, Controller, and peripheral equipment.

Space for teaching

Space for maintenance and inspection

(Ensure a space to open the covers and plates for maintenance.)

Space for cables

The minimum bend radius of the power cable is 90 mm. When installing the cable, be sure to maintain sufficient distance from obstacles. In addition, leave enough space for other cables so that they are not bent forcibly.

Ensure distance to the safeguard from the maximum motion range is more than 100 mm.

#### 3.3.1 LS3-401\*

Standard-Model: LS3-401S

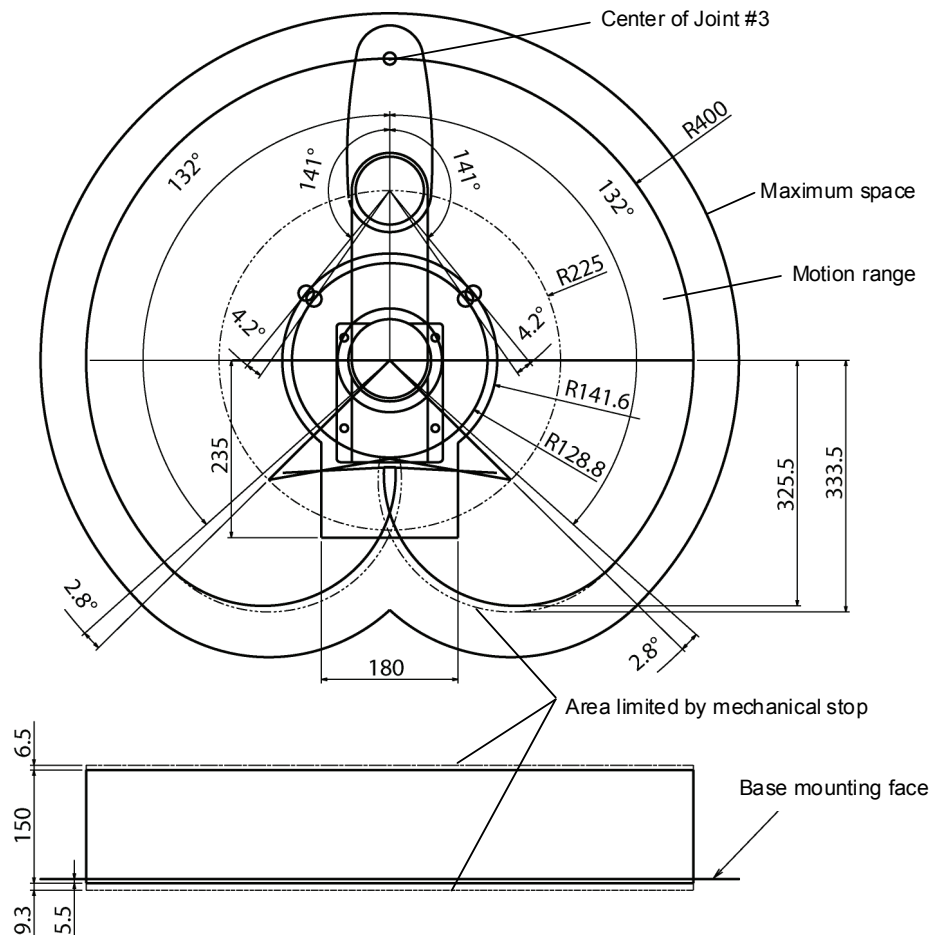

Cleanroom-Model: LS3-401C

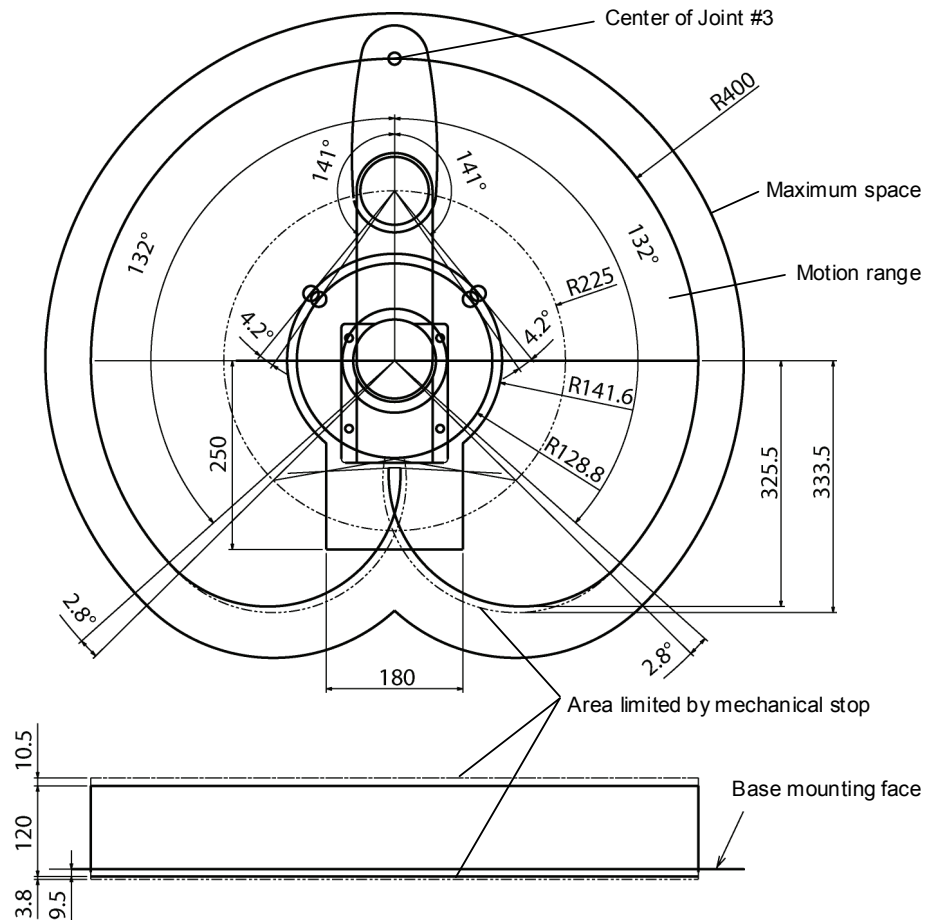

3.3.2 LS6-602\*

Standard-Model: LS6-602S

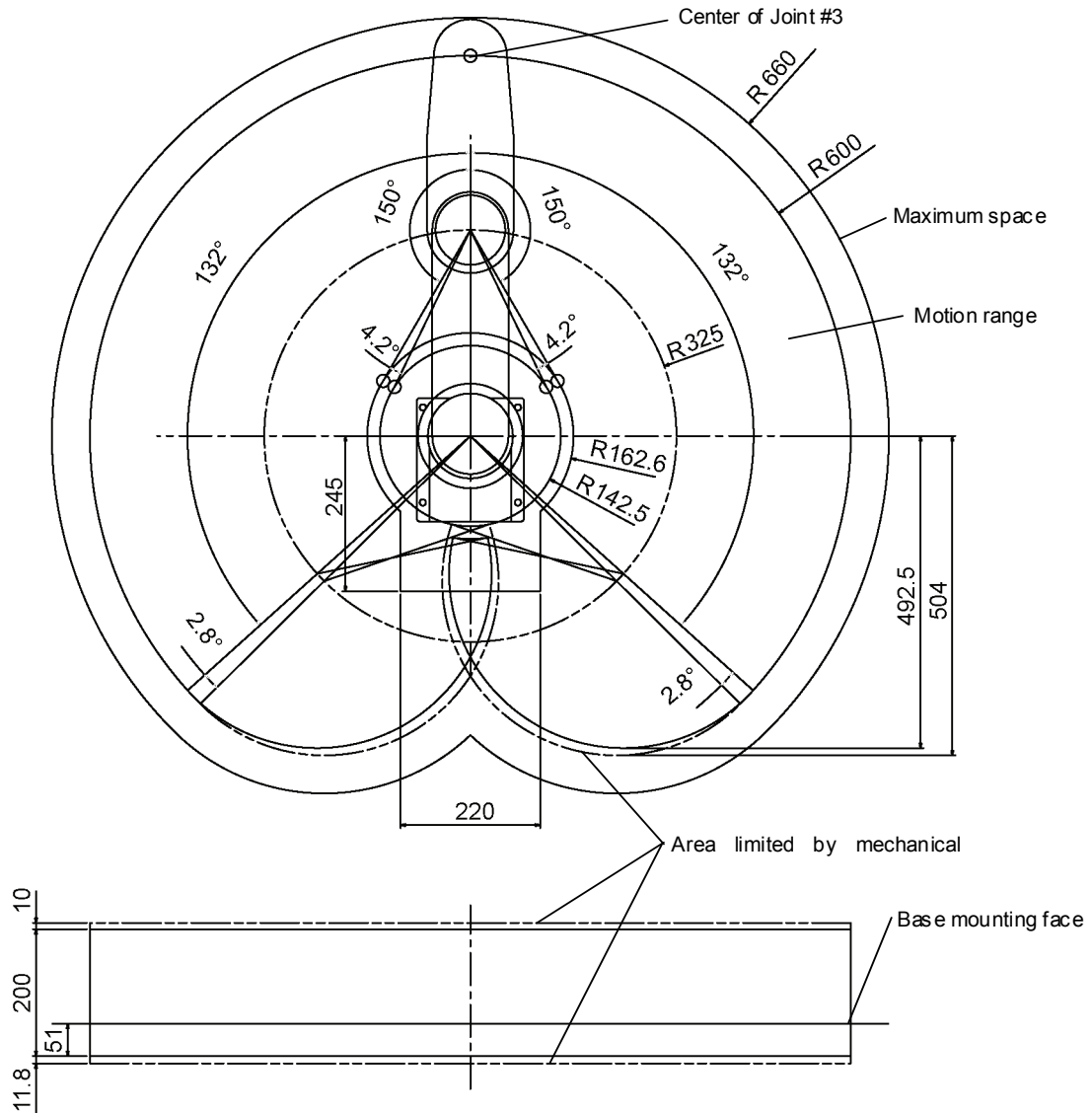

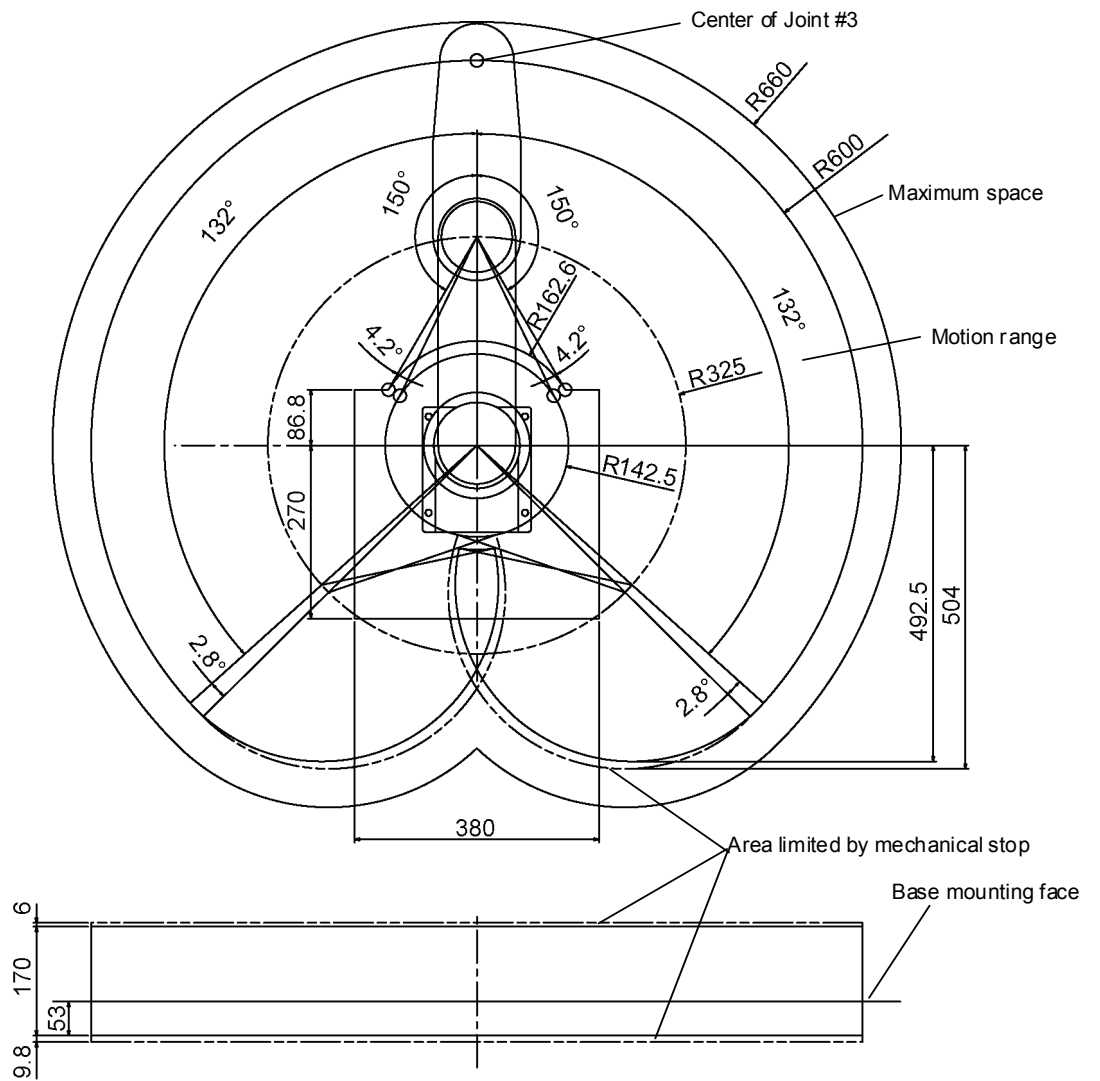

Cleanroom-Model: LS6-602C



### 3.4 Unpacking and Transportation

THE INSTALLATION SHALL BE PREFORMED BY QUALIFIED INSTALLATION PERSONNEL AND SHOULD CONFORM TO ALL NATIONAL AND LOCAL CODES.

 <b>WARNING</b>	<ul style="list-style-type: none"> <li>Only authorized personnel should perform sling work and operate a crane and a forklift. When these operations are performed by unauthorized personnel, it is extremely hazardous and may result in serious bodily injury and/or severe equipment damage to the robot system.</li> </ul>
---	--

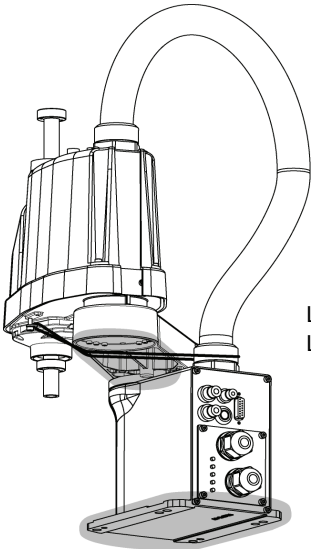
 <b>CAUTION</b>	<ul style="list-style-type: none"> <li>Using a cart or similar equipment, transport the Manipulator in the same manner as it was delivered.</li> <li>After removing the bolts securing the Manipulator to the delivery equipment, the Manipulator can fall. Be careful not to get hands or fingers caught.</li> <li>The arm is secured with a wire tie. Leave the wire tie secured until you finish the installation so as not to get hands or fingers caught.</li> <li>To carry the Manipulator, have two or more people to work on it and secure the Manipulator to the delivery equipment or hold the areas indicated in gray in the figure (bottom of Arm #1 and bottom of the base) by hand. When holding the bottom of the base by hand, be very careful not to get your hands or fingers caught.</li> </ul> <div style="text-align: center;">  <p style="margin-left: 200px;">                     LS3-401*: approx. 14 kg :31 lb.                      LS6-602*: approx. 17 kg :37.5 lb.                 </p> <p style="margin-left: 200px;">Figure : LS3-401*</p> </div> <ul style="list-style-type: none"> <li>Stabilize the Manipulator with your hands when hoisting it.</li> <li>When transporting the Manipulator for a long distance, secure it to the delivery equipment directly so that the Manipulator never falls. If necessary, pack the Manipulator in the same style as it was delivered.</li> </ul>
---	--



## 3.5 Installation Procedure

 CAUTION	<ul style="list-style-type: none"> <li>The robot system must be installed to avoid interference with buildings, structures, utilities, other machines and equipment that may create a trapping hazard or pinch points.</li> </ul>
--	---

### 3.5.1 Standard-Model

 CAUTION	<ul style="list-style-type: none"> <li>Install the Table Top Mounting Manipulator with two or more people. The Manipulator weights are as follows. Be careful not to get hands, fingers, or feet caught and/or have equipment damaged by a fall of the Manipulator.</li> </ul> <p style="text-align: center;">                     LS3-401* : approx. 14 kg: 31 lb.                      LS6-602* : approx. 17 kg: 37.5 lb.                 </p>
--	--

#### Standard-model

- Secure the base to the base table with four bolts.



**NOTE** Use bolts with specifications conforming to ISO898-1 Property Class: 10.9 or 12.9.

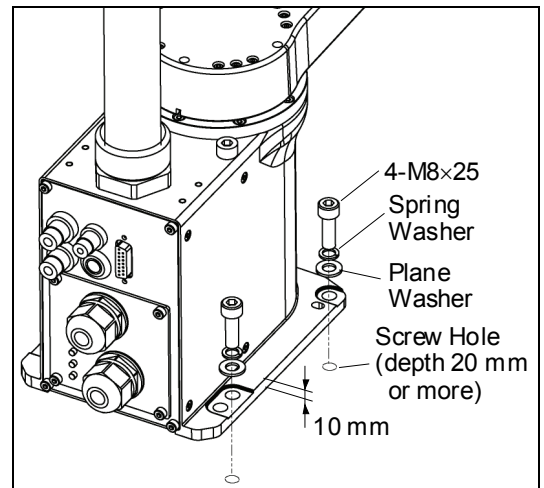

- Using nippers, cut off the wire tie binding the shaft and arm retaining bracket on the base.

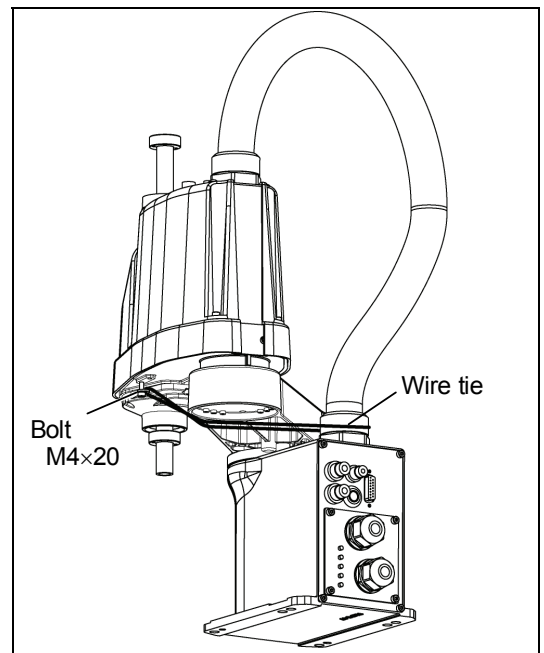

- Remove the bolts securing the wire ties removed in step (2).



### 3.5.2 Cleanroom-Model

- (1) Unpack it outside of the clean room.
- (2) Secure the Manipulator to delivery equipment such as a pallet with bolts so that the Manipulator does not fall.
- (3) Wipe off the dust on the Manipulator with a little alcohol or distilled water on a lint-free cloth.
- (4) Carry the Manipulator in the clean room.
- (5) Refer to the installation procedure of each Manipulator model and install the Manipulator.
- (6) Connect an exhaust tube to the exhaust port.

## 3.6 Connecting the Cables

 WARNING	<ul style="list-style-type: none"> <li>■ To shut off power to the robot system, pull out the power plug from the power source. Be sure to connect the AC power cable to a power receptacle. DO NOT connect it directly to a factory power source.</li> <li>■ Before performing any replacement procedure, turn OFF the Controller and related equipment, and then pull out the power plug from the power source. Performing any replacement procedure with the power ON is extremely hazardous and may result in electric shock and/or malfunction of the robot system.</li> <li>■ Be sure to connect the cables properly. Do not allow unnecessary strain on the cables. (Do not put heavy objects on the cables. Do not bend or pull the cables forcibly.) The unnecessary strain on the cables may result in damage to the cables, disconnection, and/or contact failure. Damaged cables, disconnection, or contact failure is extremely hazardous and may result in electric shock and/or improper function of the robot system.</li> <li>■ Grounding the manipulator is done by connecting with the controller. Ensure that the controller is grounded and the cables are correctly connected. If the ground wire is improperly connected to ground, it may result in the fire or electric shock.</li> </ul>
 CAUTION	<ul style="list-style-type: none"> <li>■ When connecting the Manipulator to the Controller, make sure that the serial numbers on each equipment match. Improper connection between the Manipulator and Controller may not only cause improper function of the robot system but also serious safety problems. The connection method varies with the Controller used. For details on the connection, refer to the <i>Controller manual</i>. If the G series Manipulator or E2 series Manipulator is connected to the Controller for the PS series (ProSix), it may result in malfunction of the Manipulator.</li> </ul>

When the Manipulator is a Cleanroom-model, be aware of the followings.

For the Manipulator of Cleanroom-model, use it with an exhaust system.

For details, refer to *Setup & Operation: 2.4 Specifications*.

### Cable Connections

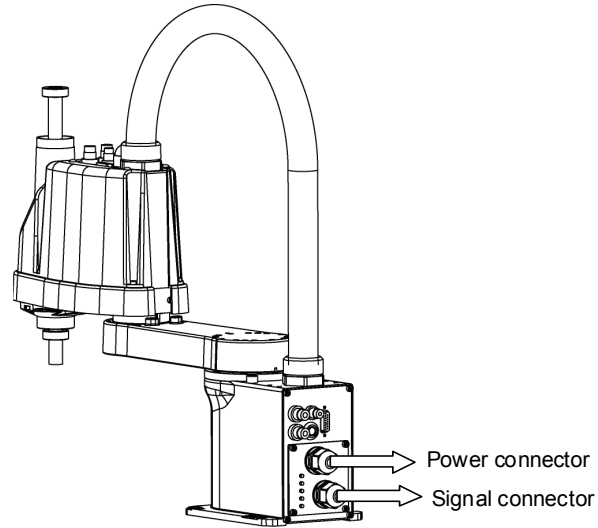

### 3.7 User Wires and Pneumatic Tubes

 <b>CAUTION</b>	<ul style="list-style-type: none"> <li>Only authorized or certified personnel should be allowed to perform wiring. Wiring by unauthorized or uncertified personnel may result in bodily injury and/or malfunction of the robot system.</li> </ul>
---	---

User electrical wires and pneumatic tubes are contained in the cable unit.

#### Electrical Wires

Rated Voltage	Allowable Current	Wires	Nominal Sectional Area	Note
AC/DC30 V	1 A	15	0.211 mm <sup>2</sup>	Twist pair

 <b>WARNING</b>	<ul style="list-style-type: none"> <li>Do not apply the current more than 1A to the manipulator.</li> </ul>
---	---

		Maker	Standard
15 pin	Suitable Connector	JAE	DA-15PF-N (Solder type)
	Clamp Hood	JAE	DA-C8-J10-F2-1R (Connector setscrew: #4-40 NC)

Pins with the same number, indicated on the connectors on both ends of the cables, are connected.

#### Pneumatic Tubes

Max. Usable Pneumatic Pressure	Pneumatic Tubes	Outer Diameter × Inner Diameter
0.59 MPa (6 kgf/cm <sup>2</sup> : 86 psi)	2	ø 6 mm × ø 4 mm
	1	ø 4 mm × ø 2.5 mm

Fittings for ø6 mm and ø4 mm (outer diameter) pneumatic tubes are supplied on both ends of the pneumatic tubes.

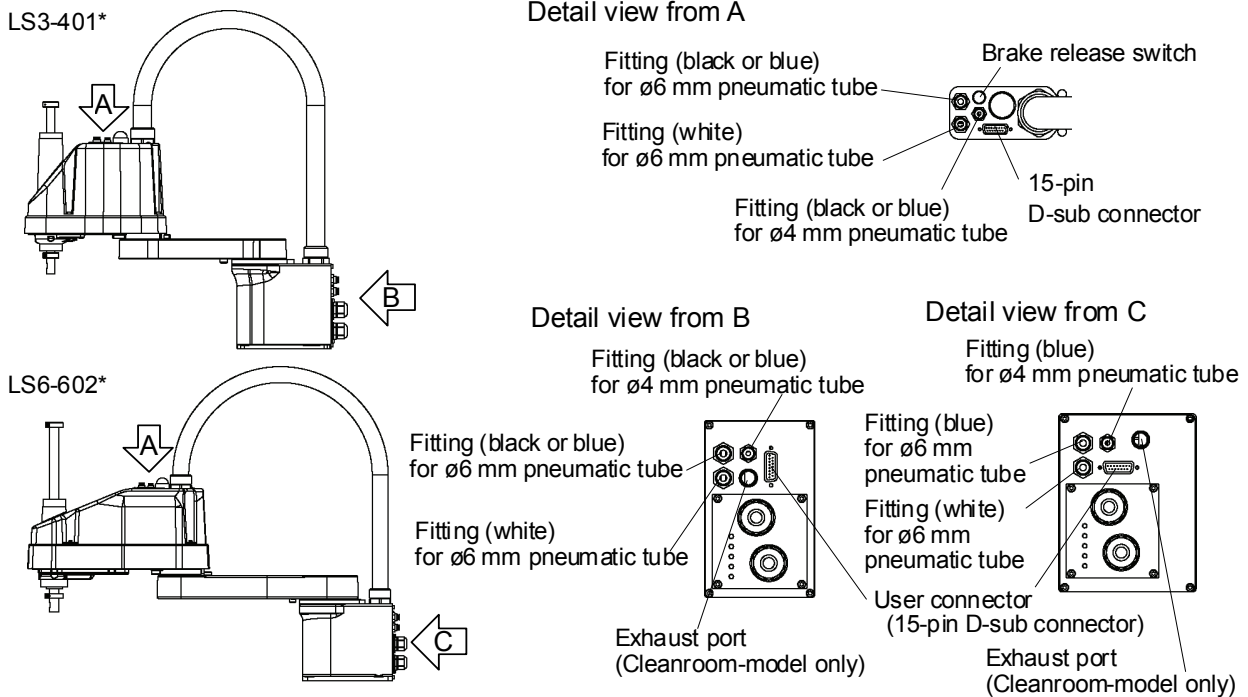



## 3.8 Relocation and Storage

### 3.8.1 Precautions for Relocation and Storage

Observe the following when relocating, storing, and transporting the Manipulators.

THE INSTALLATION SHALL BE PREFORMED BY QUALIFIED INSTALLATION PERSONNEL AND SHOULD CONFORM TO ALL NATIONAL AND LOCAL CODES.

 <b>WARNING</b>	<ul style="list-style-type: none"> <li>■ Only authorized personnel should perform sling work and operate a crane and a forklift. When these operations are performed by unauthorized personnel, it is extremely hazardous and may result in serious bodily injury and/or severe equipment damage to the robot system.</li> </ul>
---	--

 <b>CAUTION</b>	<ul style="list-style-type: none"> <li>■ Before relocating the Manipulator, fold the arm and secure it tightly with a wire tie to prevent hands or fingers from being caught in the Manipulator.</li> <li>■ When removing the anchor bolts, support the Manipulator to prevent falling. Removing the anchor bolts without support may result in a fall of the Manipulator, and then get hands, fingers, or feet caught.</li> <li>■ To carry the Manipulator, have two or more people to work on it and secure the Manipulator to the delivery equipment or hold the bottom of Arm #1, the bottom of the main cable fitting, and the bottom of the base by hand. When holding the bottom of the base by hand, be very careful not to get hands or fingers caught.</li> <li>■ Stabilize the Manipulator with your hands when hoisting it. Unstable hoisting is extremely hazardous and may result in fall of the Manipulator.</li> </ul>
---	--

When transporting the Manipulator for a long distance, secure it to the delivery equipment so that the Manipulator cannot fall.

If necessary, pack the Manipulator in the same way as it was delivered.

When the Manipulator is used for a robot system again after long-term storage, perform a test run to verify that it works properly, and then operate it thoroughly.

Transport and store the Manipulator in the range of -25°C to +55°C.

Humidity within 10% to 90% is recommended.

When condensation occurs on the Manipulator during transport or storage, turn ON the power only after the condensation dries.

Do not shock or shake the Manipulator during transport.

### 3.8.2 Relocation

 CAUTION	<ul style="list-style-type: none"> <li>■ Install or relocate the Manipulator with two or more people. The Manipulator weights are as follows. Be careful not to get hands, fingers, or feet caught and/or have equipment damaged by a fall of the Manipulator.                     <ul style="list-style-type: none"> <li>LS3-401* : approx. 14 kg: 31 lb.</li> <li>LS6-602* : approx. 17 kg: 37.5 lb.</li> </ul> </li> </ul>
--	---

- (1) Turn OFF the power on all devices and unplug the cables.

NOTE



Remove the mechanical stops if using them to limit the motion range of Joints #1 and #2. For details on the motion range, refer to *Setup & Operation: 5.2 Motion Range Setting by Mechanical Stops*.

- (2) Cover the arm with a sheet so that the arm will not be damaged.  
Tie the lower end of the shaft and arm, and the base and arm together with the wire tie.  
Be careful not to tie them too tight. Otherwise, the shaft may bend.

Example of Arm Retaining Posture

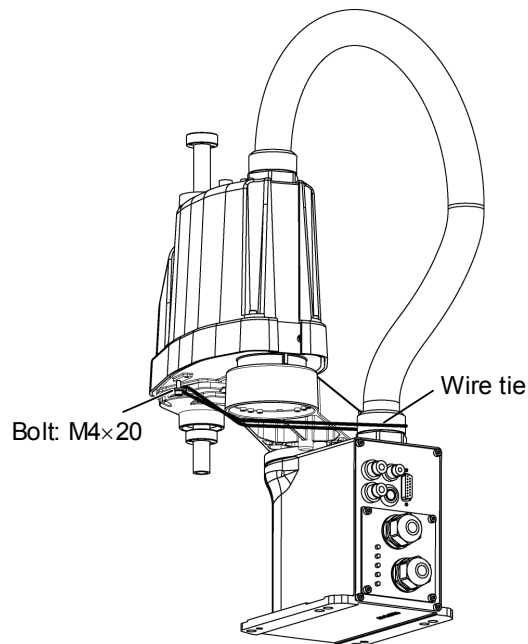

- (3) Hold the bottom of Arm #1 by hand to unscrew the anchor bolts. Then, remove the Manipulator from the base table.

## 4. Setting of End Effectors

### 4.1 Attaching an End Effector

Users are responsible for making their own end effector(s). Before attaching an end effector, observe these guidelines.

 <b>CAUTION</b>	<ul style="list-style-type: none"> <li>■ If you use an end effector equipped with a gripper or chuck, connect wires and/or pneumatic tubes properly so that the gripper does not release the work piece when the power to the robot system is turned OFF. Improper connection of the wires and/or pneumatic tubes may damage the robot system and/or work piece as the work piece is released when the Emergency Stop switch is pressed. I/O outputs are configured at the factory so that they are automatically shut off (0) by power disconnection, the Emergency Stop switch, or the safety features of the robot system.</li> </ul>
---	--

#### Shaft

- Attach an end effector to the lower end of the shaft.  
For the shaft dimensions, and the overall dimensions of the Manipulator, refer to *Setup & Operation: 2. Specifications*.
- Do not move the upper limit mechanical stop on the lower side of the shaft. Otherwise, when “Jump motion” is performed, the upper limit mechanical stop may hit the Manipulator, and the robot system may not function properly.
- Use a split muff coupling with an M4 bolt or larger to attach the end effector to the shaft.

#### Brake release switch : LS3

- Joint #3 cannot be moved up/down by hand because the solenoid brake is applied to the joint while power to the robot system is turned OFF.

This prevents the shaft from hitting peripheral equipment in the case that the shaft is lowered by the weight of the end effector when the power is disconnected during operation, or when the motor is turned OFF even though the power is turned ON.

To move Joint #3 up/down while attaching an end effector, turn ON the Controller and press the brake release switch.

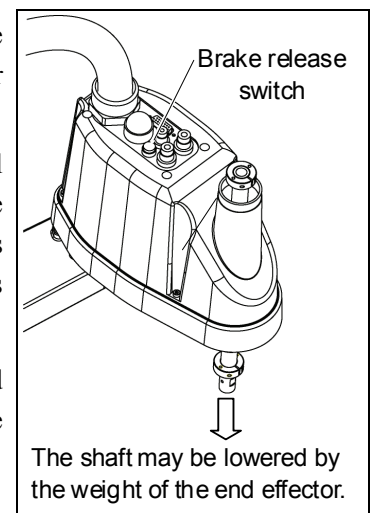

This button switch is a momentary-type; the brake is released only while the button switch is being pressed.

- Be careful of the shaft while the brake release switch is being pressed because the shaft may be lowered by the weight of the end effector.

Brake release switch : LS6

- Joint #3 and #4 cannot be moved up/down by hand because the solenoid brake is applied to the joint while power to the robot system is turned OFF.

This prevents the shaft from hitting peripheral equipment in the case that the shaft is lowered by the weight of the end effector when the power is disconnected during operation, or when the motor is turned OFF even though the power is turned ON.

To move Joint #3 up/down or rotate Joint #4 while attaching an end effector, turn ON the Controller and move the joint up/down or rotate the joint while pressing the brake release switch.

This button switch is a momentary-type; the brake is released only while the button switch is being pressed.

The respective brakes for Joints #3 and #4 are released simultaneously.

- Be careful of the shaft while the brake release switch is being pressed because the shaft may be lowered by the weight of the end effector.

Layouts

- When you operate the manipulator with an end effector, the end effector may interfere with the Manipulator because of the outer diameter of the end effector, the size of the work piece, or the position of the arms. When designing your system layout, pay attention to the interference area of the end effector.



## 4.2 Attaching Cameras and Valves

The bottom of the Arm #2 has threaded holes as shown in the figure below. Use these holes for attaching cameras, valves, and other equipment. [Unit: mm]

LS3-401\*

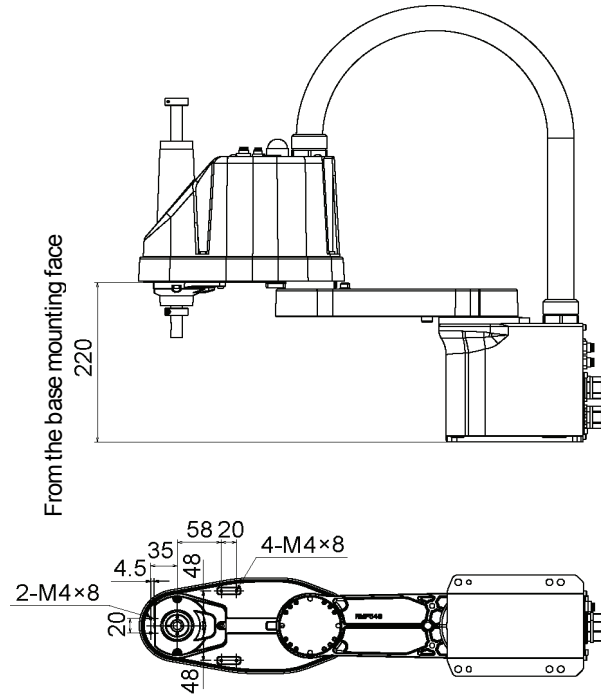

LS6-602\*

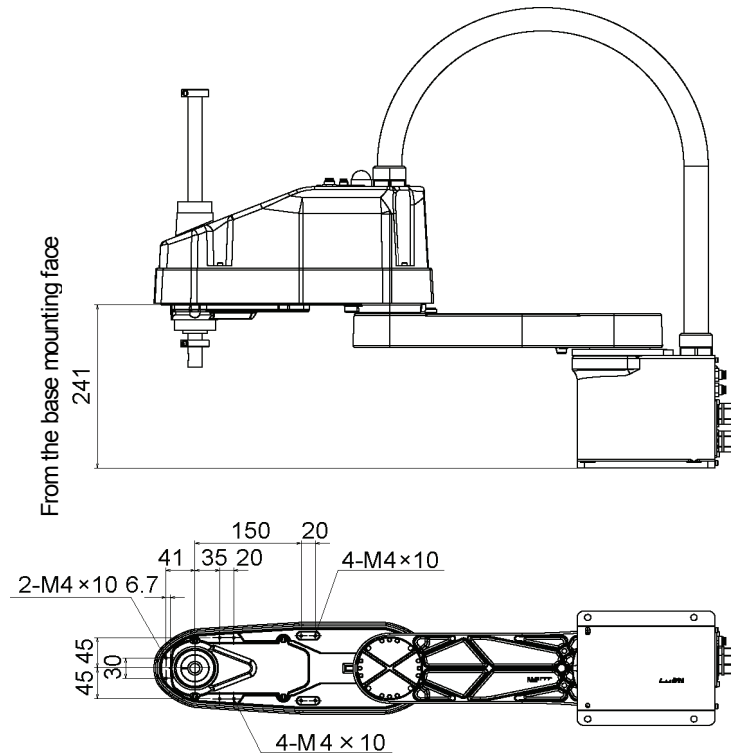

## 4.3 Weight and Inertia Settings

To ensure optimum Manipulator performance, it is important to make sure that the load (weight of the end effector and work piece) and moment of inertia of the load are within the maximum rating for the Manipulator, and that Joint #4 does not become eccentric.

If the load or moment of inertia exceeds the rating or if the load becomes eccentric, follow the steps below, “4.3.1 Weight Setting” and “4.3.2 Inertia Setting” to set parameters.

Setting parameters makes the PTP motion of the Manipulator optimal, reduces vibration to shorten the operating time, and improves the capacity for larger loads. In addition, it reduces persistent vibration produced when the moment of inertia of the end effector and work piece is larger than the default setting.

### 4.3.1 Weight Setting

 CAUTION	<ul style="list-style-type: none"> <li>■ The total weight of the end effector and the work piece must not exceed LS3: 3 kg / LS6: 6 kg. The LS series Manipulators are not designed to work with loads exceeding LS3: 3 kg / LS6: 6 kg. Always set the Weight parameters according to the load. Setting a value that is smaller than the actual load may cause errors, excessive shock, insufficient function of the Manipulator, and/or shorten the life cycle of parts/mechanisms.</li> </ul>
--	---

The acceptable weight capacity (end effector and work piece) in LS series is

LS3: 1 kg at the default rating / 3 kg at the maximum,

LS6: 2 kg at the default rating / 6 kg at the maximum.

When the load (weight of the end effector and work piece) exceeds the rating, change the setting of Weight parameter.

After the setting is changed, the maximum acceleration/deceleration speed of the robot system at PTP motion corresponding to the “Weight Parameter” is set automatically.

#### Load on the Shaft

The load (weight of the end effector and work piece) on the shaft can be set by Weight parameter.

EPSON  
RC+

Enter a value into the [Load inertia:] text box on the [Inertia] panel ([Tools] - [Robot Manager]). (You may also execute the Inertia command from the [Command Window].)

#### Load on the Arm

When you attach a camera or other devices to the arm, calculate the weight as the equivalent of the shaft. Then, add this to the load and enter the total weight to the Weight parameter.

## Equivalent Weight Formula

When you attach the equipment near Arm #2:  $W_M = M (L_1)^2 / (L_1 + L_2)^2$

When you attach the equipment to the end of Arm #2:  $W_M = M (L_M)^2 / (L_2)^2$

$W_M$  : equivalent weight

$M$  : weight of camera etc.

$L_1$  : length of Arm #1

$L_2$  : length of Arm #2

$L_M$  : distance from rotation center of Joint #2 to center of gravity of camera etc.

<Example> A “1 kg” camera is attached to the end of the LS3 series arm (180 mm away from the rotation center of Joint #2) with a load weight of “1 kg”.

$$M=1$$

$$L_2=175$$

$$L_M=225$$

$$W_M=1 \times 225^2 / 175^2 = 1.653 \rightarrow 1.7 \text{ (round up)}$$

$$W + W_M = 1 + 1.7 = 2.7$$

Enter “2.7” for the Weight Parameter.

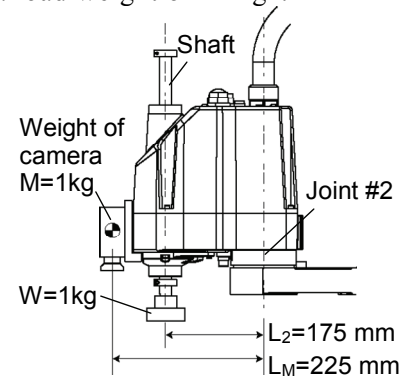

## 4.3.2 Inertia Setting

## Moment of Inertia and the Inertia Setting

The moment of inertia is defined as “the ratio of the torque applied to a rigid body and its resistance to motion”. This value is typically referred to as “the moment of inertia”, “inertia”, or “GD<sup>2</sup>”. When the Manipulator operates with additional objects (such as an end effector) attached to the shaft, the moment of inertia of load must be considered.



CAUTION

- The moment of inertia of the load (weight of the end effector and work piece) must be LS3: 0.05 kg·m<sup>2</sup> / LS6: 0.12 kg·m<sup>2</sup> or less. The LS series Manipulators are not designed to work with a moment of inertia exceeding LS3: 0.05 kg·m<sup>2</sup> / LS6: 0.12 kg·m<sup>2</sup>.

Always set the moment of inertia parameter to the correct moment of inertia. Setting a value that is smaller than the actual moment of inertia may cause errors, excessive shock, insufficient function of the Manipulator, and/or shorten the life cycle of parts/mechanisms.

The acceptable moment of inertia of load for a LS series Manipulator is LS3: 0.005 kg·m<sup>2</sup> at the default rating and 0.05 kg·m<sup>2</sup> at the maximum.

LS6: 0.01 kg·m<sup>2</sup> at the default rating and 0.12 kg·m<sup>2</sup> at the maximum.

When the moment of inertia of the load exceeds the rating, change the setting of the moment of inertia parameter of the Inertia command. After the setting is changed, the maximum acceleration/deceleration speed of Joint #4 at PTP motion corresponding to the “moment of inertia” value is set automatically.

**Moment of inertia of load on the shaft**

The moment of inertia of load (weight of the end effector and work piece) on the shaft can be set by the “moment of inertia” parameter of the Inertia command.

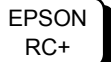

Enter a value into the [Load inertia:] text box on the [Inertia] panel ([Tools] - [Robot Manager]). (You may also execute the Inertia command from the [Command Window].)

**Eccentric Quantity and the Inertia Setting**



CAUTION

- The eccentric quantity of load (weight of the end effector and work piece) must be 150 mm or less. The LS series Manipulators are not designed to work with eccentric quantity exceeding 150 mm. Always set the eccentric quantity parameter according to the eccentric quantity. Setting a value that is smaller than the actual eccentric quantity may cause errors, excessive shock, insufficient function of the Manipulator, and/or shorten the life cycle of parts/mechanisms.

The acceptable eccentric quantity of load in LS series is 0 mm at the default rating and 150 mm at the maximum. When the eccentric quantity of load exceeds the rating, change the setting of eccentric quantity parameter of Inertia command. After the setting is changed, the maximum acceleration/deceleration speed of the Manipulator at PTP motion corresponding to the “eccentric quantity” is set automatically.

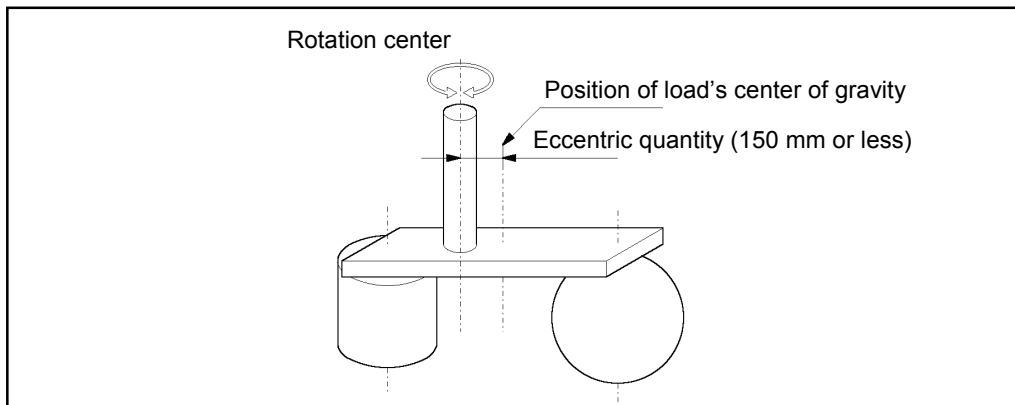

Eccentric Quantity

**Eccentric quantity of load on the shaft**

The eccentric quantity of load (weight of the end effector and work piece) on the shaft can be set by “eccentric quantity” parameter of Inertia command.

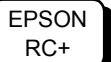

Enter a value into the [Eccentricity:] text box on the [Inertia] panel ([Tools] - [Robot Manager]). (You may also execute the Inertia command from the [Command Window].)

**Calculating the Moment of Inertia**

Refer to the following examples of formulas to calculate the moment of inertia of load (end effector with work piece).

The moment of inertia of the entire load is calculated by the sum of each part (a), (b), and (c).

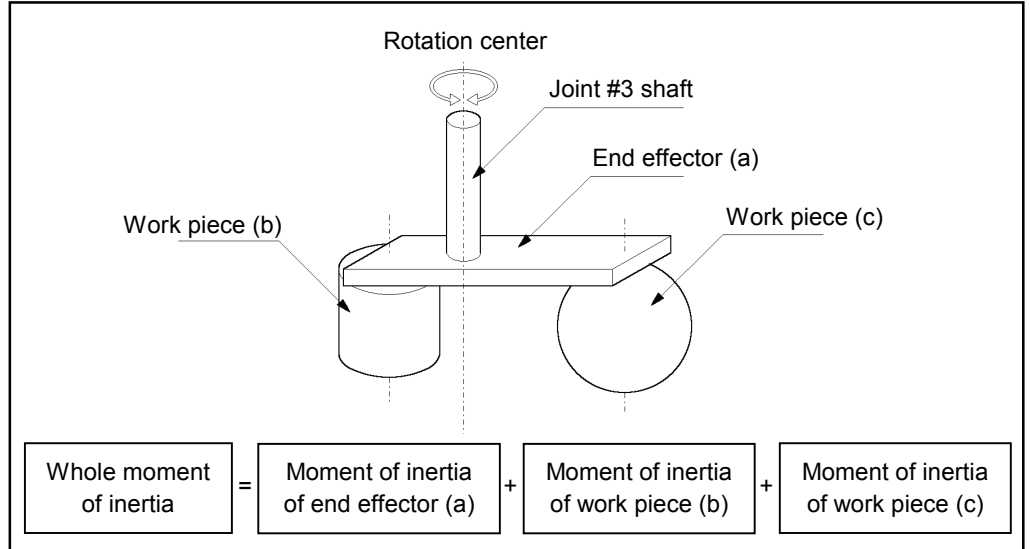

The methods for calculating the moment of inertia for (a), (b), and (c) are shown below. Calculate the total moment of inertia using the basic formulas.

(a) Moment of inertia of a rectangular parallelepiped

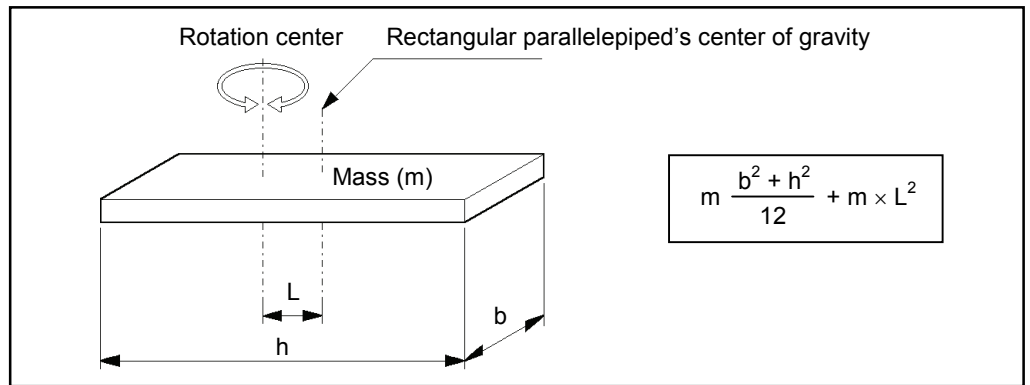

(b) Moment of inertia of a cylinder

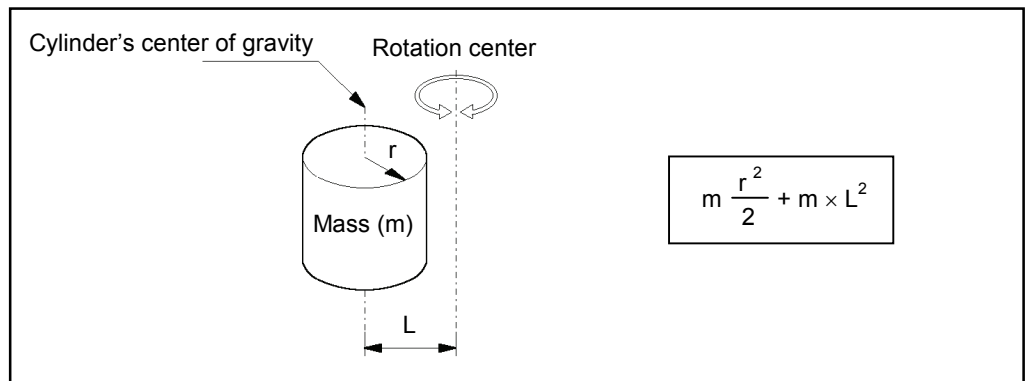

(c) Moment of inertia of a sphere

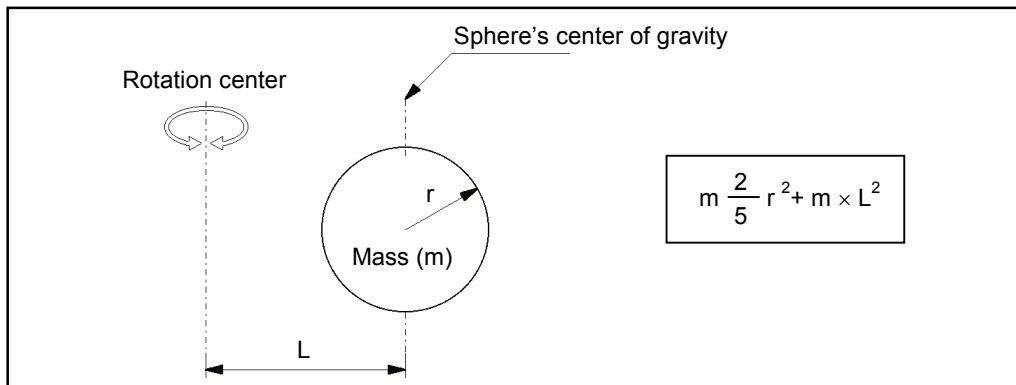

## 4.4 Precautions for Auto Acceleration/Deceleration of Joint #3

When you move the Manipulator in horizontal PTP motion with Joint #3 (Z) at a high position, the motion time will be faster.

When Joint #3 gets below a certain point, then auto acceleration/deceleration is used to reduce acceleration/deceleration. The higher the position of the shaft is, the faster the motion acceleration/deceleration is. However, it takes more time to move Joint #3 up and down. Adjust the position of Joint #3 for the Manipulator motion after considering the relation between the current position and the destination position.

The upper limit of Joint #3 during horizontal motion using Jump command can be set by the LimZ command.



When moving the Manipulator horizontally while the shaft is being lowered, it may cause over-shoot at the time of final positioning.

## 5. Motion Range



CAUTION

- When setting up the motion range for safety, both the pulse range and mechanical stops must always be set at the same time.

The motion range is preset at the factory as explained in *Setup & Operation: 5.4 Standard Motion Range*. That is the maximum motion range of the Manipulator.

There are three methods for setting the motion range described as follows:

1. Setting by pulse range (for all joints)
2. Setting by mechanical stops (for Joints #1 to #3)
3. Setting the Cartesian (rectangular) range in the X, Y coordinate system of the Manipulator (for Joints #1 and #2)

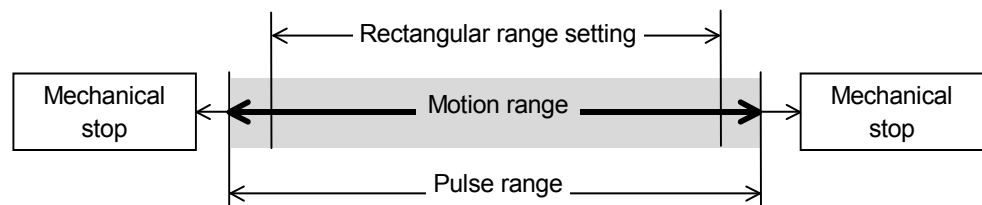

When the motion range is changed due to layout efficiency or safety, follow the descriptions in 5.1 to 5.3 to set the range.

### 5.1 Motion Range Setting by Pulse Range (for All Joints)

Pulses are the basic unit of Manipulator motion. The motion range of the Manipulator is controlled by the pulse range between the pulse lower limit and upper limit of each joint. Pulse values are read from the encoder output of the servo motor.

For the maximum pulse range, refer to the following sections.

The pulse range must be set inside of the mechanical stop range.

*5.1.1 Max. Pulse Range of Joint #1*

*5.1.2 Max. Pulse Range of Joint #2*

*5.1.3 Max. Pulse Range of Joint #3*

*5.1.4 Max. Pulse Range of Joint #4.*

NOTE



Once the Manipulator receives an operating command, it checks whether the target position specified by the command is within the pulse range before operating. If the target position is out of the set pulse range, an error occurs and the Manipulator does not move.

EPSON  
RC+

The pulse range can be set on the [Range] panel shown by selecting [Tools]-[Robot Manager]. (You may also execute the Range command from the [Command Window].)

### 5.1.1 Max. Pulse Range of Joint #1

The 0 (zero) pulse position of Joint #1 is the position where Arm #1 faces toward the positive (+) direction on the X-coordinate axis.

When the 0 pulse is a starting point, the counterclockwise pulse value is defined as the positive (+) and the clockwise pulse value is defined as the negative (-).

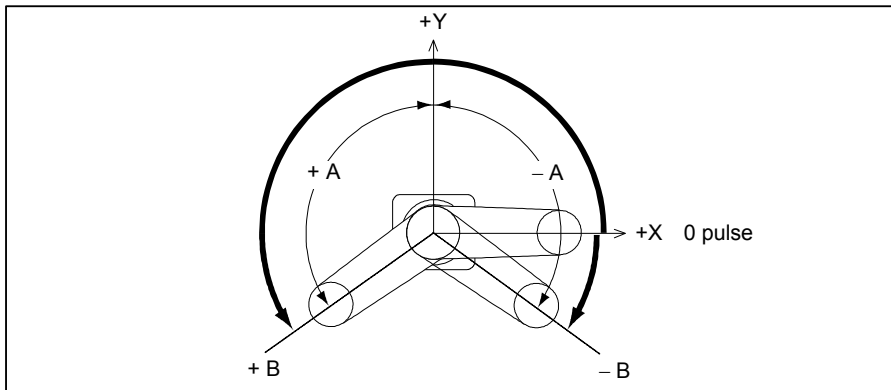

	A: Max. Motion Range	B: Max. Pulse Range
LS3-401*	±132 deg.	- 95574~505174 pulse
LS6-602*		- 152918~808278 pulse

### 5.1.2 Max. Pulse Range of Joint #2

The 0 (zero) pulse position of Joint #2 is the position where Arm #2 is in-line with Arm #1.

With the 0 pulse as a starting point, the counterclockwise pulse value is defined as the positive (+) and the clockwise pulse value is defined as the negative (-).

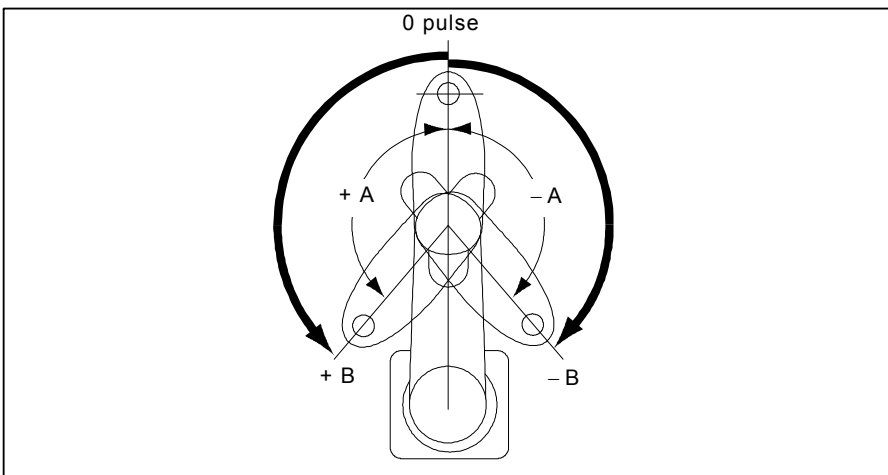

	A: Max. Motion Range	B: Max. Pulse Range
LS3-401*	± 141 deg.	± 320854 pulse
LS6-602*	± 150 deg.	± 341334 pulse



**5.1.3 Max. Pulse Range of Joint #3**

The 0 (zero) pulse position of Joint #3 is the position where the shaft is at its upper limit. The pulse value is always negative because Joint #3 always moves lower than the 0 pulse position.

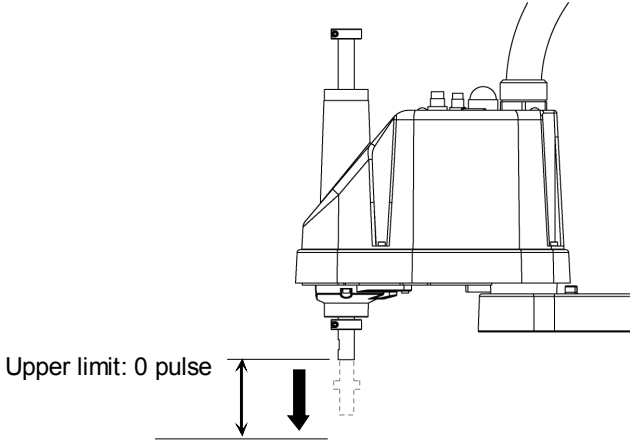

	Joint #3 Stroke	Lower Limit Pulse
LS3-401S (Standard-model)	150 mm	-187734 pulse
LS3-401C (Cleanroom-model)	120 mm	-150187 pulse
LS6-602S (Standard-model)	200 mm	-245760 pulse
LS6-602C (Cleanroom-model)	170 mm	-208896 pulse



NOTE For the Cleanroom-model (LS3-401C/LS6-602C), the motion range set with the Joint #3 mechanical stop cannot be changed.

**5.1.4 Max. Pulse Range of Joint #4**

The 0 (zero) pulse position of Joint #4 is the position where the flat near the end of the shaft faces toward the end of Arm #2. With the 0 pulse as a starting point, the counterclockwise pulse value is defined as the positive (+) and the clockwise pulse value is defined as the negative (-).

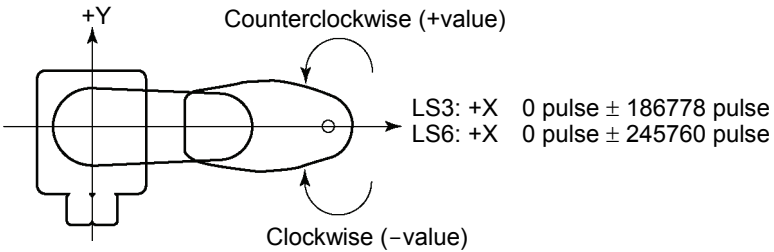

## 5.2 Motion Range Setting by Mechanical Stops

Mechanical stops physically limit the absolute area that the Manipulator can move.

Both Joints #1 and #2 have threaded holes in the positions corresponding to the angle for the mechanical stop settings. Install the bolts in the holes corresponding to the angle that you want to set.

Joints #3 can be set to any length less than the maximum stroke.

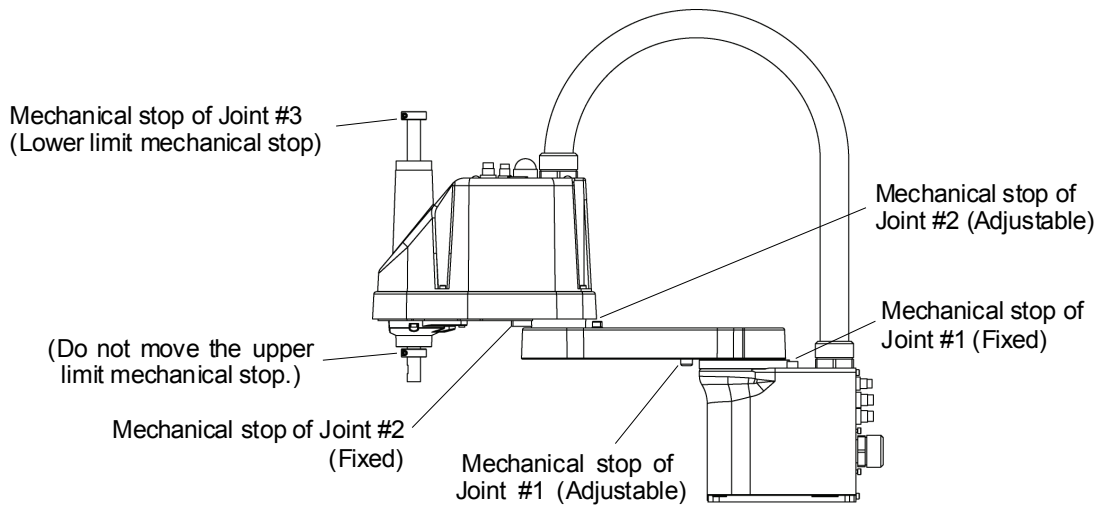

**5.2.1 Setting the Mechanical Stops of Joints #1 and #2**

Both Joints #1 and #2 have threaded holes in the positions corresponding to the angle for the mechanical stop settings. Install the bolts in the holes corresponding to the angle that you want to set.

Install the bolts for the mechanical stop to the following position.

**Joint #1 Mechanical Stops**

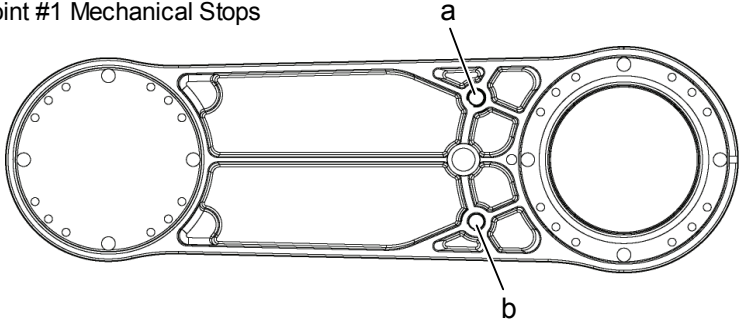

Views from the bottom of Arm #1

		a	b
LS3-401*	Setting Angle	110 deg.	-110 deg.
	Pulse Value	455112 pulse	-45512 pulse
LS6-602*	Setting Angle	115 deg	-115 deg
	Pulse Value	746383 pulse	-91023 pulse

**Joint #2 Mechanical Stops**

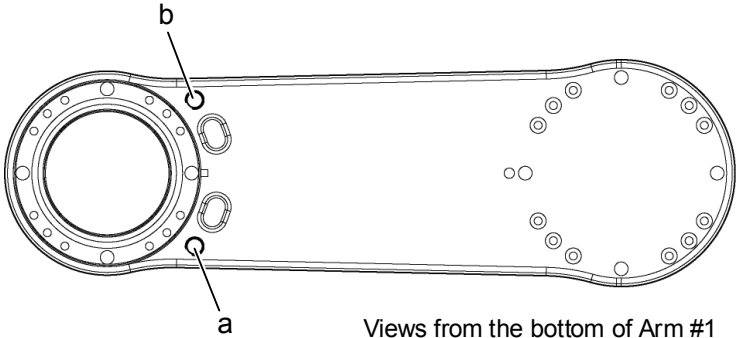

Views from the bottom of Arm #1

Views from the top of Arm #1

		a	b
LS3-401* / LS6-602*	Setting Angle	125 deg.	-125 deg.
	Pulse Value	284445 pulse	-284445 pulse

- (1) Turn OFF the Controller.
- (2) Install a hexagon socket head cap bolt into the hole corresponding to the setting angle, and tighten it.

Joint	Hexagon socket head cap bolt (fully threaded)	The number of bolts	Recommended tightening torque
1	M8 × 10	1 bolt / one side	3720 N·cm (380 kgf·cm)

- (3) Turn ON the Controller.
- (4) Set the pulse range corresponding to the new positions of the mechanical stops.



Be sure to set the pulse range inside the positions of the mechanical stop range.

Example: Using LS3-401S

The angle of Joint #1 is set from -110 degrees to +110 degrees.

The angle of Joint #2 is set from -125 degrees to +125 degrees.



Execute the following commands from the [Command Window].

```
>JRANGE 1, -45512, 455112      ' Sets the pulse range of Joint #1
>JRANGE 2, -284445, 284445    ' Sets the pulse range of Joint #2
>RANGE                          ' Checks the setting using Range
-45512, 455112, -284445, 284445, -150187
, 0, -186778, 186778
```

- (5) Move the arm by hand until it touches the mechanical stops, and make sure that the arm does not hit any peripheral equipment during operation.
- (6) Operate the joint changed at low speeds until it reaches the positions of the minimum and maximum pulse range. Make sure that the arm does not hit the mechanical stops. (Check the position of the mechanical stop and the motion range you set.)

Example: Using LS3-401S

The angle of Joint #1 is set from -110 degrees to +110 degrees.

The angle of Joint #2 is set from -125 degrees to +125 degrees.

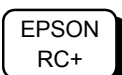

Execute the following commands from the [Command Window].

```
>MOTOR ON                       'Turns ON the motor
>CP ON                           'Enters low-power mode
>SPEED 5                          'Sets at low speeds
>PULSE -45512, 0, 0, 0           'Moves to the min. pulse position of Joint #1
>PULSE 455112, 0, 0, 0          'Moves to the max. pulse position of Joint #1
>PULSE 204800, -284445, 0, 0    'Moves to the min. pulse position of Joint #2
>PULSE 204800, 284445, 0, 0     'Moves to the max. pulse position of Joint #2
```

The Pulse command (Go Pulse command) moves all joints to the specified positions at the same time. Specify safe positions after considering motion of not only the joints whose pulse range have been changed, but also other joints.

In this example, Joint #1 is moved to the center of its motion range (pulse value: 204800) when checking Joint #2.

If the arm is hitting the mechanical stops or if an error occurs after the arm hits the mechanical stops, either reset the pulse range to a narrower setting or extend the positions of the mechanical stops within the limit.

### 5.2.2 Setting the Mechanical Stop of Joint #3



This method applies only to the Standard-model manipulator (LS3-401S).  
 For the Cleanroom-model (LS3-401C), the motion range set with the Joint #3 mechanical stop cannot be changed.

- (1) Turn ON the Controller and turn OFF the motors using the Motor OFF command.
- (2) Push up the shaft while pressing the brake release switch.

Do not push the shaft up to its upper limit or it will be difficult for the arm top cover to be removed. Push the shaft up to a position where the Joint #3 mechanical stop can be changed.

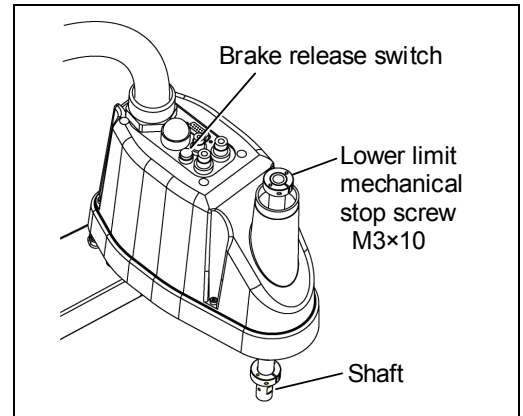

When you press the brake release switch, the shaft may lower due to the weight of the end effector. Be sure to hold the shaft by hand while pressing the button.

- (3) Turn OFF the Controller.
- (4) Loosen the lower limit mechanical stop screw (M3×10).



A mechanical stop is mounted on both the top and bottom of Joint #3. However, only the position of the lower limit mechanical stop on the top can be changed. Do not remove the upper limit mechanical stop on the bottom because the calibration point of Joint #3 is specified using the stop.

- (5) The upper end of the shaft defines the maximum stroke. Move the lower limit mechanical stop down by the length you want to limit the stroke. For example, when the lower limit mechanical stop is set at “150 mm” stroke, the lower limit Z coordinate value is “-150”. To change the value to “-130”, move the lower limit mechanical stop down “20 mm”. Use calipers to measure the distance when adjusting the mechanical stop.

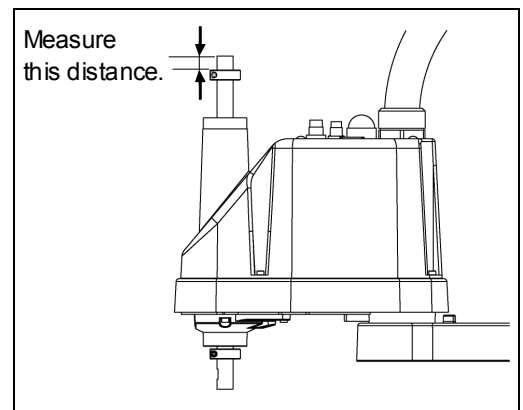

- (6) Firmly tighten the lower limit mechanical stop screw (M3×10).  
 Recommended tightening torque: 245 N·cm (25 kgf·cm)
- (7) Turn ON the Controller.

- (8) Move Joint #3 to its lower limit while pressing the brake release switch, and then check the lower limit position. Do not lower the mechanical stop too far. Otherwise, the joint may not reach a target position.
- (9) Calculate the lower limit pulse value of the pulse range using the formula shown below and set the value.

The result of the calculation is always negative because the lower limit Z coordinate value is negative.

Lower limit of pulse (pulse)  
= lower limit Z coordinate value (mm) / Resolution (mm/pulse)

\*\* For the Joint #3 resolution,  
refer to the section *Setup & Operation 2.4 Specifications*.



Execute the following command from the [Command Window]. Enter the calculated value in X.

>JRANGE 3, X, 0 ' Sets the pulse range of Joint #3

- (10) Using the Pulse command (Go Pulse command), move Joint #3 to the lower limit position of the pulse range at low speed. If the mechanical stop range is less than the pulse range, Joint #3 will hit the mechanical stop and an error will occur. When the error occurs, either change the pulse range to a lower setting or extend the position of the mechanical stop within the limit.

NOTE



If it is difficult to check whether Joint #3 hits a mechanical stop, turn OFF the Controller and lift the arm top cover to check the condition causing the problem from the side.

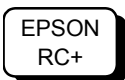

Execute the following commands from the [Command Window]. Enter the value calculated in Step (10) in X.

>MOTOR ON ' Turns ON the motor

>SPEED 5 ' Sets low speed

>PULSE 0, 0, X, 0 ' Moves to the lower limit-pulse position of Joint #3.

(In this example, all pulses except those for Joint #3 are “0”. Substitute these “0s” with the other pulse values specifying a position where there is no interference even when lowering Joint #3.)

### 5.3 Setting the Cartesian (Rectangular) Range in the XY Coordinate System of the Manipulator (for Joints #1 and #2)

Use this method to set the upper and lower limits of the X and Y coordinates.

This setting is only enforced by software. Therefore, it does not change the physical range. The maximum physical range is based on the position of the mechanical stops.

EPSON  
RC+

Set the XYLim setting on the [XYZ Limits] panel shown by selecting [Tools]-[Robot Manager].

(You may also execute the XYLim command from the [Command Window].)

### 5.4 Standard Motion Range

The following “motion range” diagrams show the standard (maximum) specification. When each Joint motor is under servo control, the center of Joint #3’s (shaft’s) lowest point moves in the areas shown in the figure.

“Area limited by mechanical stop” is the area where the center of Joint #3’s lowest point can be moved when each joint motor is not under servo control.

“Mechanical stop” sets the limited motion range so that the center of Joint #3 cannot move beyond the area mechanically.

“Maximum space” is the area that contains the farthest reach of the arms. If the maximum radius of the end effector is over 60 mm, add the “Area limited by mechanical stop” and “radius of the end effector”. The total value is specified as the maximum area.

For the motion area figures, refer to *Setup & Operation 3.3 Mounting Dimensions*.





# Maintenance

This volume contains maintenance procedures with safety precautions for LS series Manipulators.



# 1. Safety Maintenance

Please read this chapter, this manual, and other relevant manuals carefully to understand safe maintenance procedures before performing any routine maintenance.

Only authorized personnel who have taken safety training should be allowed to maintain the robot system.

Safety training is the program for industrial robot operators that follows the laws and regulations of each nation.

The personnel who have taken safety training acquire knowledge of industrial robots (operations, teaching, etc.), knowledge of inspections, and knowledge of related rules/regulations.

The personnel who have completed the robot system-training and maintenance-training classes held by the manufacturer, dealer, or locally-incorporated company are allowed to maintain the robot system.



WARNING

- Do not remove any parts that are not covered in this manual. Follow the maintenance procedure strictly as described in this manual. Improper removal of parts or improper maintenance may not only cause improper function of the robot system but also serious safety problems.
- Keep away from the Manipulator while the power is ON if you have not taken the training courses. Do not enter the operating area while the power is ON. Entering the operating area with the power ON is extremely hazardous and may cause serious safety problems as the Manipulator may move even it seems to be stopped.
- When you check the operation of the Manipulator after replacing parts, be sure to check it while you are outside of the safeguarded area. Checking the operation of the Manipulator while you are inside of the safeguarded area may cause serious safety problems as the Manipulator may move unexpectedly.
- Before operating the robot system, make sure that both the Emergency Stop switches and safeguard switch function properly. Operating the robot system when the switches do not function properly is extremely hazardous and may result in serious bodily injury and/or serious damage to the robot system as the switches cannot fulfill their intended functions in an emergency.



WARNING

- To shut off power to the robot system, pull out the power plug from the power source. Be sure to connect the AC power cable to a power receptacle. DO NOT connect it directly to a factory power source.
- Before performing any replacement procedure, turn OFF the Controller and related equipment, and then pull out the power plug from the power source. Performing any replacement procedure with the power ON is extremely hazardous and may result in electric shock and/or malfunction of the robot system.

 CAUTION	<ul style="list-style-type: none"> <li>Be sure to connect the cables properly. Do not allow unnecessary strain on the cables. (Do not put heavy objects on the cables. Do not bend or pull the cables forcibly.) The unnecessary strain on the cables may result in damage to the cables, disconnection, and/or contact failure. Damaged cables, disconnection, or contact failure is extremely hazardous and may result in electric shock and/or improper function of the robot system.</li> </ul>
--	---

## 2. General Maintenance

This chapter describes maintenance inspections and procedures. Performing maintenance inspections and procedures properly is essential for preventing trouble and ensuring safety. Be sure to perform the maintenance inspections in accordance with the schedule.

### 2.1 Schedule for Maintenance Inspection

Inspection points are divided into five stages: daily, monthly, quarterly, biannual, and annual. The inspection points are added every stage. If the Manipulator is operated for 250 hours or longer per month, the inspection points must be added every 250 hours, 750 hours, 1500 hours, and 3000 hours operation.

	Inspection Point				
	Daily inspection	Monthly inspection	Quarterly inspection	Biannual inspection	Annual inspection
1 month (250 h)	Inspect every day	√			
2 months (500 h)		√			
3 months (750 h)		√	√		
4 months (1000 h)		√			
5 months (1250 h)		√			
6 months (1500 h)		√	√	√	
7 months (1750 h)		√			
8 months (2000 h)		√			
9 months (2250 h)		√	√		
10 months (2500 h)		√			
11 months (2750 h)		√			
12 months (3000 h)		√	√	√	√
13 months (3250 h) ⋮		⋮	⋮	⋮	⋮

h = hour

## 2.2 Inspection Point

### 2.2.1 Inspection While the Power is OFF (Manipulator is not operating)

Inspection Point	Inspection Place	Daily	Monthly	Quarterly	Biannual	Annual
Check looseness or backlash of bolts/screws. Tighten them if necessary. (For the tightening torque, refer to <i>Maintenance: 2.4 Tightening Hexagon Socket Head Cap Bolts.</i> )	End effector mounting bolts	√	√	√	√	√
	Manipulator mounting bolts	√	√	√	√	√
	Each arm locking bolts	√	√	√	√	√
	Bolts/screws around shaft					√
	Bolts/screws securing motors, reduction gear units, etc.					√
Check looseness of connectors. If the connectors are loosen, push it securely or tighten.	External connectors on Manipulator (on the connector plates etc.)	√	√	√	√	√
	Manipulator cable unit		√	√	√	√
Visually check for external defects. Clean up if necessary.	External appearance of Manipulator	√	√	√	√	√
	External cables		√	√	√	√
Check for bends or improper location. Repair or place it properly if necessary.	Safeguard etc.	√	√	√	√	√
Check tension of timing belts. Tighten it if necessary.	Inside of Arm #2				√	√
Grease conditions	Refer to <i>Maintenance: 2.3 Greasing.</i>					
Battery	-	Replace every 1.5 years				

### 2.2.2 Inspection While the Power is ON (Manipulator is operating)

Inspection Point	Inspection Place	Daily	Monthly	Quarterly	Biannual	Annual
Check motion range	Each joint					√
Move the cables back and forth lightly to check whether the cables are disconnected.	External cables (including cable unit of the Manipulator)				√	√
Push each arm in MOTOR ON status to check whether backlash exists.	Each arm					√
Check whether unusual sound or vibration occurs.	Whole	√	√	√	√	√
Measure the accuracy repeatedly by a gauge.	Whole					√
Turn ON and OFF the brake release switch and check the sound of the electromagnetic brake. If there is no sound, replace the brake.	Brake	√	√	√	√	√

## 2.3 Greasing

The ball screw spline and reduction gear units need greasing regularly. Only use the grease specified in the following table.

 CAUTION	<ul style="list-style-type: none"> <li>■ Keep enough grease in the Manipulator. Operating the Manipulator with insufficient grease will damage sliding parts and/or result in insufficient function of the Manipulator. Once the parts are damaged, a lot of time and money will be required for the repairs.</li> </ul>
--	--

	Greasing part	Greasing Interval	Grease	Refer to:
Joint #1	Reduction gear units	In the replacement of motor*	SK-1A	<i>Maintenance: 5 Joint #1</i>
Joint #2	Reduction gear units	In the replacement of motor*	SK-2	<i>Maintenance: 6 Joint #2</i>
Joint #3	Ball screw spline shaft	Every 6 months	AFB	<i>Maintenance: 10. Greasing the Ball Screw Spline Unit</i>

\* Under normal conditions, the reduction gear units shall be greased only when the motor is replaced. However, in case of severe working conditions (such as high duty, high speeds, large payloads, etc.), the reduction gear units must be greased every 10,000 hours.

 CAUTION	<ul style="list-style-type: none"> <li>■ If grease gets into your eyes, mouth, or on your skin, follow the instructions below.                     <ul style="list-style-type: none"> <li>If grease gets into your eyes                             <ul style="list-style-type: none"> <li>: Flush them thoroughly with clean water, and then see a doctor immediately.</li> </ul> </li> <li>If grease gets into your mouth                             <ul style="list-style-type: none"> <li>: If swallowed, do not induce vomiting. See a doctor immediately.</li> <li>: If grease just gets into your mouth, wash out your mouth with water thoroughly.</li> </ul> </li> <li>If grease gets on your skin                             <ul style="list-style-type: none"> <li>: Wash the area thoroughly with soap and water.</li> </ul> </li> </ul> </li> </ul>
--	--

## 2.4 Tightening Hexagon Socket Head Cap Bolts

Hexagon socket head cap bolts are used in places where mechanical strength is required. (A hexagon socket head cap bolt will be called a “bolt” in this manual.) These bolts are fastened with the tightening torques shown in the following table.

When it is necessary to refasten these bolts in some procedures in this manual (except special cases as noted), use a torque wrench so that the bolts are fastened with the appropriate tightening torques as shown below.

Bolt	Tightening Torque
M3	245 N·cm (25 kgf·cm)
M4	490 N·cm (50 kgf·cm)
M5	980 N·cm (100 kgf·cm)
M6	1,760 N·cm (180 kgf·cm)
M8	3,720 N·cm (380 kgf·cm)
M10	7,350 N·cm (750 kgf·cm)
M12	12,740 N·cm (1,300 kgf·cm)

Refer below for the set screw.

Set Screw	Tightening Torque
M4	245 N·cm (25 kgf·cm)
M5	392 N·cm (40 kgf·cm)

The bolts aligned on a circumference should be fastened in a crisscross pattern as shown in the figure below.

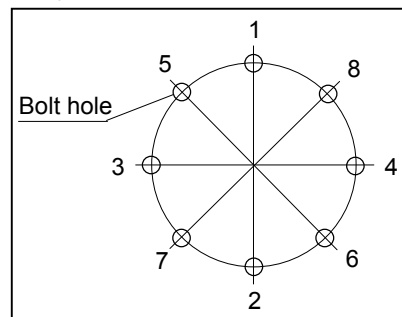

Do not fasten all bolts securely at one time. Divide the number of times that the bolts are fastened into two or three and fasten the bolts securely with a hexagonal wrench. Then, use a torque wrench so that the bolts are fastened with tightening torques shown in the table above.

## 2.5 Matching Origins

After parts have been replaced (motors, reduction gear units, a brake, timing belts, a ball screw spline unit, etc.), the Manipulator cannot operate properly because a mismatch exists between the origin stored in each motor and its corresponding origin stored in the Controller. After replacing the parts, it is necessary to match these origins.

For calibration, the pulse values for a specific position must be recorded in advance. Before replacing parts, select easy point (pose) data from the registered point data to check the accuracy. Then, follow the steps below to display the pulse values and record them.

EPSON  
RC+

Execute the following command from the [Command Window].

```
>PULSE
```

```
PULSE: [Joint #1 Pulse value] pls [Joint #2 Pulse value] pls [Joint #3 Pulse value]
pls [Joint #4 Pulse value] pls
```

## 2.6 Layout of Maintenance Parts

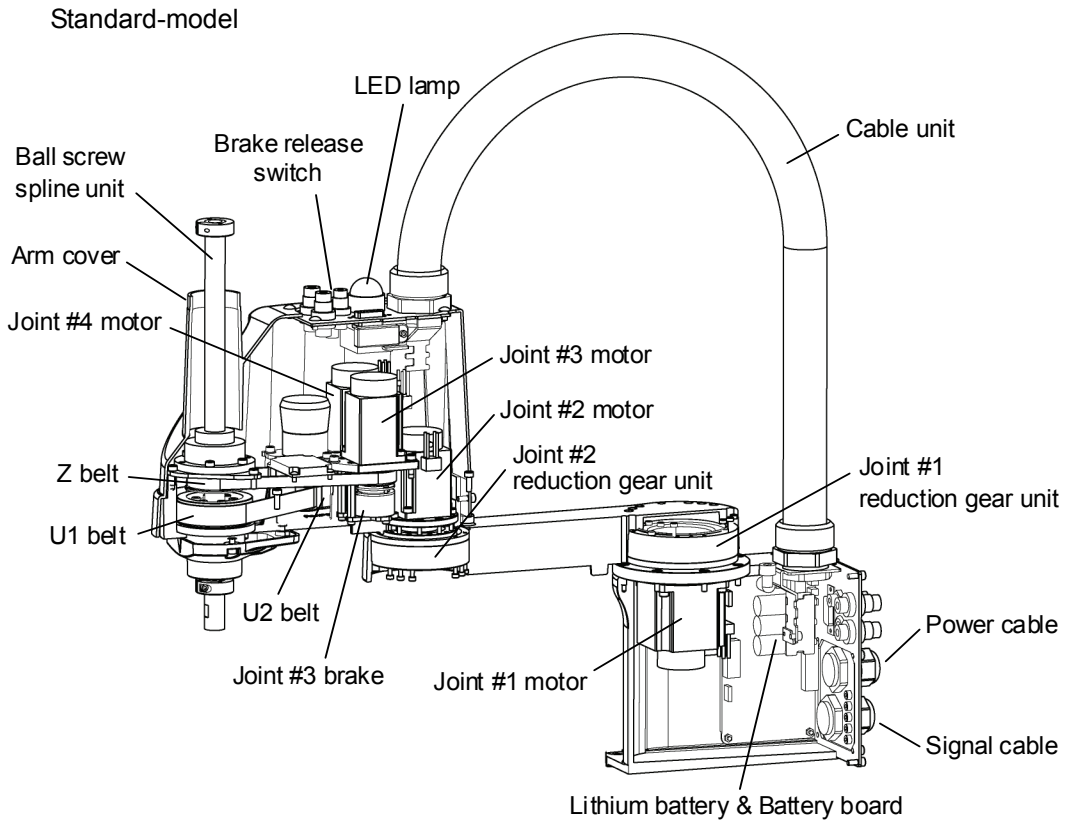

(Figure: LS3-401S)

Cleanroom-model (with optional bellows)

For the Cleanroom-model, the following parts are added to the Standard-model.

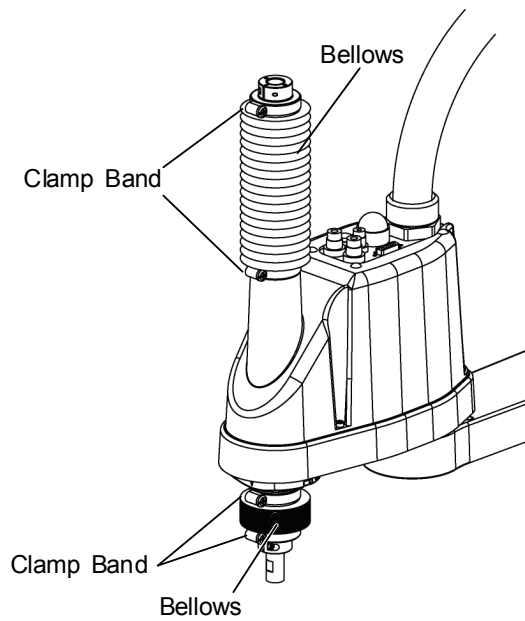

(Figure: LS3-401C)



### 3. Covers

All procedures for removing and installing covers in maintenance are described in this chapter.

 <p>WARNING</p>	<ul style="list-style-type: none"> <li>■ Do not insert or pull out the motor connectors while the power to the robot system is turned ON. Inserting or pulling out the motor connectors with the power ON is extremely hazardous and may result in serious bodily injury as the Manipulator may move abnormally, and also may result in electric shock and/or malfunction of the robot system.</li> <li>■ To shut off power to the robot system, pull out the power plug from the power source. Be sure to connect the AC power cable to a power receptacle. DO NOT connect it directly to a factory power source.</li> <li>■ Before performing any replacement procedure, turn OFF the Controller and related equipment, and then pull out the power plug from the power source. Performing any replacement procedure with the power ON is extremely hazardous and may result in electric shock and/or malfunction of the robot system.</li> <li>■ Be careful not to get any foreign substances in the Manipulator, connectors, and pins during maintenance. Turning ON the power to the robot system when any foreign substances exist in them is extremely hazardous and may result in electric shock and/or malfunction of the robot system.</li> </ul>
--	---

(Figure: LS3-401S)

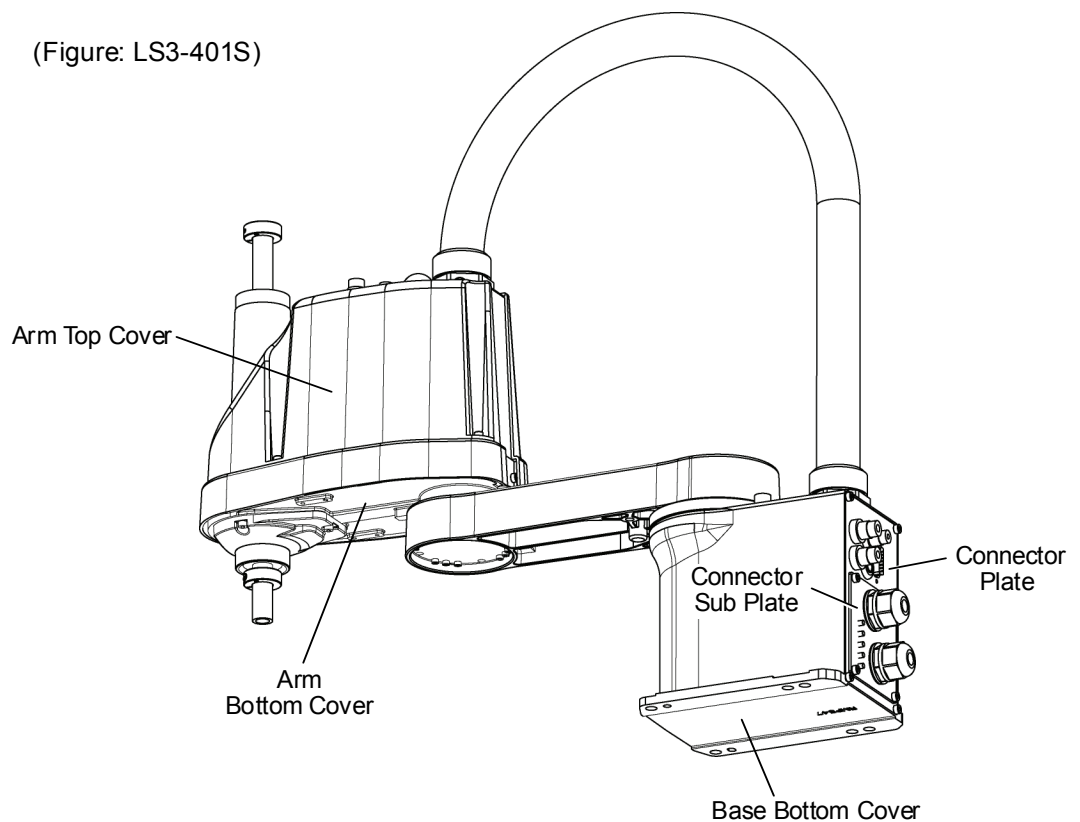

### 3.1 Arm Top Cover



CAUTION

- Do not remove the arm top cover forcibly. Removing the cover forcibly may result in damage to the cables, disconnection, and/or contact failure. Damaged cables, disconnection, or contact failure is extremely hazardous and may result in electric shock and/or improper function of the robot system.
  - When installing the cover, be careful not to allow the cables to interfere with the cover mounting and do not bend these cables forcibly to push them into the cover. Unnecessary strain on cables may result in damage to the cables, disconnection, and/or contact failure. Damaged cables, disconnection, or contact failure is extremely hazardous and may result in electric shock and/or improper function of the robot system.
- When routing the cables, observe the cable locations after removing the cover. Be sure to place the cables back to their original locations.

**Arm Top Cover Removal**      Unscrew the Arm Top Cover mounting bolts, and then lift the cover.

**NOTE** When bellows are installed to the manipulator, remove the upper bellows and then remove the Arm Top Cover. For bellows removal, refer to *Maintenance 9. Bellows*.

Be careful for user wires and tubes when removing the cover.

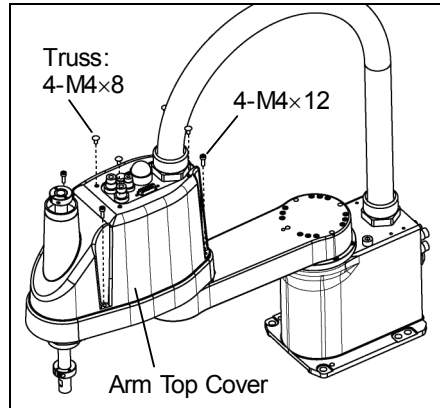

**Arm Top Cover Installation**      Put the arm top cover to the arm and secure with the Arm Top Cover mounting bolts. After securing the Arm Top Cover, make sure that the lower limit mechanical stop is not touching the cylindrical part of the Arm Top Cover.

### 3.2 Arm Bottom Cover

Unscrew the Arm Bottom Cover mounting bolts and then remove the cover.

**NOTE** Be careful of the end effector. When the end effector is installed, the Arm Bottom Cover may not be removed from the shaft.

When you replace the ball screw spline unit, you need to remove the end effector to remove the Arm Bottom Cover completely.

When you can work (maintenance, inspection) without removing the cover completely, move the shaft to the lower limit and lower the Arm Bottom Cover.

When bellows are installed to the manipulator, remove or pull down the lower bellows and then remove the arm bottom cover. For bellows removal, refer to *Maintenance 9. Bellows*.

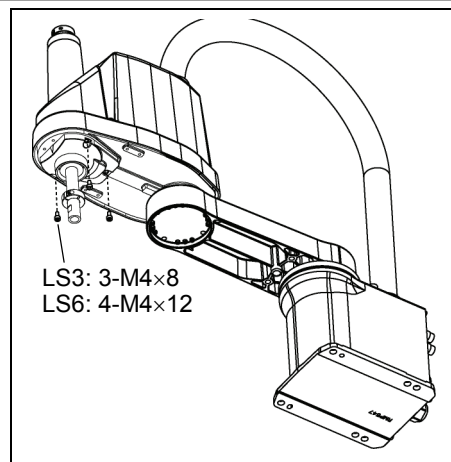

### 3.3 Connector Plate



- Do not remove the connector plate forcibly. Removing the connector plate forcibly may result in damage to the cables, disconnection, and/or contact failure. Damaged cables, disconnection, or contact failure is extremely hazardous and may result in electric shock and/or improper function of the robot system.
  - When installing the connector plate, be careful not to allow the cables to interfere with the plate mounting and do not bend these cables forcibly to push them into the cover. Unnecessary strain on cables may result in damage to the cables, disconnection, and/or contact failure. Damaged cables, disconnection, or contact failure is extremely hazardous and may result in electric shock and/or improper function of the robot system.
- When routing the cables, observe the cable locations after removing the connector plate. Be sure to place the cables back to their original locations.

Unscrew the Connector Plate mounting bolts and remove the plate.



The fittings position and size of the Connector Plate are different for LS6 and LS3.

The screws' position and size are common. The figure is LS3.



When mounting the Connector Plate, be careful of the following.

Prevent the air tube from bending sharply inside the manipulator. Also, do not block the air flow.

If there is a kink in the air tube, air flow is blocked while the manipulator is operating and may cause a trouble.

Put the air tube along the left side wall as shown in the picture.

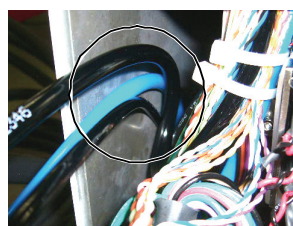
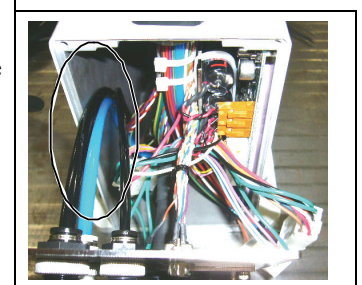
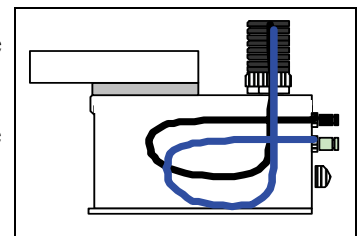
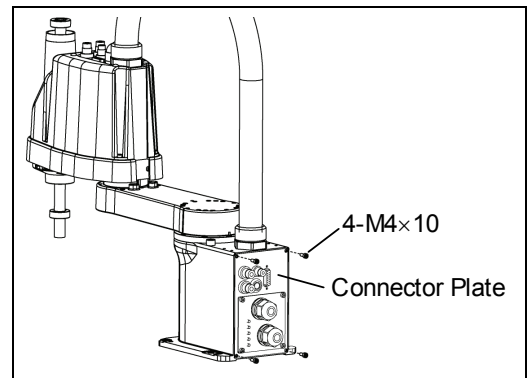

GOOD: Curved

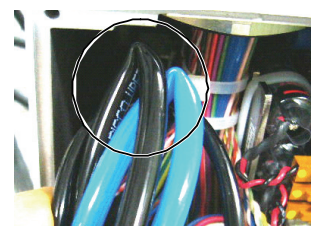

BAD: Bended

### 3.4 Connector Sub Plate

 CAUTION	<ul style="list-style-type: none"> <li>■ Do not remove the connector sub plate forcibly. Removing the connector sub plate forcibly may result in damage to the cables, disconnection, and/or contact failure. Damaged cables, disconnection, or contact failure is extremely hazardous and may result in electric shock and/or improper function of the robot system.</li> <li>■ When installing the connector sub plate, be careful not to allow the cables to interfere with the plate mounting and do not bend these cables forcibly to push them into the cover. Unnecessary strain on cables may result in damage to the cables, disconnection, and/or contact failure. Damaged cables, disconnection, or contact failure is extremely hazardous and may result in electric shock and/or improper function of the robot system. When routing the cables, observe the cable locations after removing the connector sub plate. Be sure to place the cables back to their original locations.</li> </ul>
--	--

Unscrew the Connector Sub Plate mounting bolts and remove the plate.

**NOTE**  The fittings position and size of the Connector Plate are different for LS6 and LS3. The screws' position and size are common. The figure is LS3.

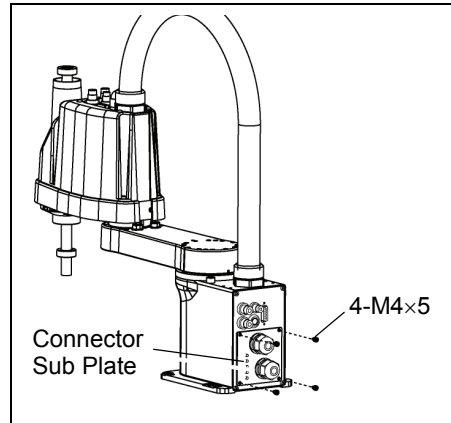



### 3.5 User Plate

- User Plate Removal**
- (1) Remove the Arm Top Cover. Refer to *Maintenance: 3.1 Arm Top Cover*.
  - (2) Unscrew the User Plate mounting bolts and remove the plate.

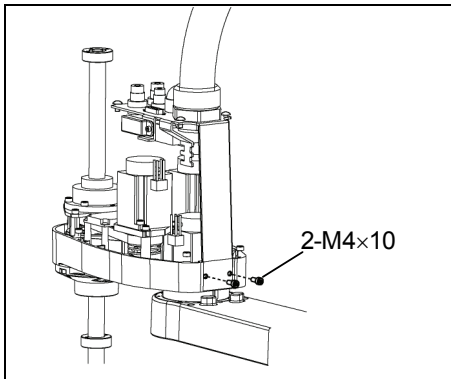
- User Plate Installation**
- (1) Put the User Plate to the arm and secure using the mounting bolts.
  - (2) Mount the Arm Top Cover. Refer to *Maintenance: 3.1 Arm Top Cover*.



## 4. Cable

 <b>WARNING</b>	<ul style="list-style-type: none"> <li>■ Do not insert or pull out the motor connectors while the power to the robot system is turned ON. Inserting or pulling out the motor connectors with the power ON is extremely hazardous and may result in serious bodily injury as the Manipulator may move abnormally, and also may result in electric shock and/or malfunction of the robot system.</li> <li>■ To shut off power to the robot system, pull out the power plug from the power source. Be sure to connect the AC power cable to a power receptacle. DO NOT connect it directly to a factory power source.</li> <li>■ Before performing any replacement procedure, turn OFF the Controller and related equipment, and then pull out the power plug from the power source. Performing any replacement procedure with the power ON is extremely hazardous and may result in electric shock and/or malfunction of the robot system.</li> <li>■ Be careful not to get any foreign substances in the Manipulator, connectors, and pins during maintenance. Turning ON the power to the robot system when any foreign substances exist in them is extremely hazardous and may result in electric shock and/or malfunction of the robot system.</li> </ul>
 <b>CAUTION</b>	<ul style="list-style-type: none"> <li>■ Be sure to connect the cables properly. Do not allow unnecessary strain on the cables. (Do not put heavy objects on the cables. Do not bend or pull the cables forcibly.) The unnecessary strain on the cables may result in damage to the cables, disconnection, and/or contact failure. Damaged cables, disconnection, or contact failure is extremely hazardous and may result in electric shock and/or improper function of the robot system.</li> </ul>

### 4.1 Replacing Cable Unit

Since the power is supplied to each motor from the lithium battery installed on the battery board via the battery connector, the position data will not be lost when the Controller is turned OFF. When the battery connectors are disconnected, the position data will be lost, and EPSON RC+ will display an error when the Controller is turned ON.

If the error occurs, execute the calibration of all joints and axes.

For details, refer to *Maintenance: 13. Calibration*.

	Name	Quantity	Note
Maintenance parts	Cable unit	1	LS3-401*: R13020059 LS6-602*: R13020060
	Battery Unit	1	R13B060007 (Lithium battery for replacement A set of 3 batteries)
Tools	Hexagonal wrench (width across flats: 3 mm)	1	For M4 screw
	Hexagonal wrench (width across flats: 4 mm)	1	For M5 screw
	Spanner (width across flats: 5 mm)	1	For D-sub connector removal
	Nut screwdriver (width across flats: 5 mm)	1	For D-sub connector removal
	Torque wrench	1	
	Nippers	1	For cutting wire tie
Material	Wire tie	-	

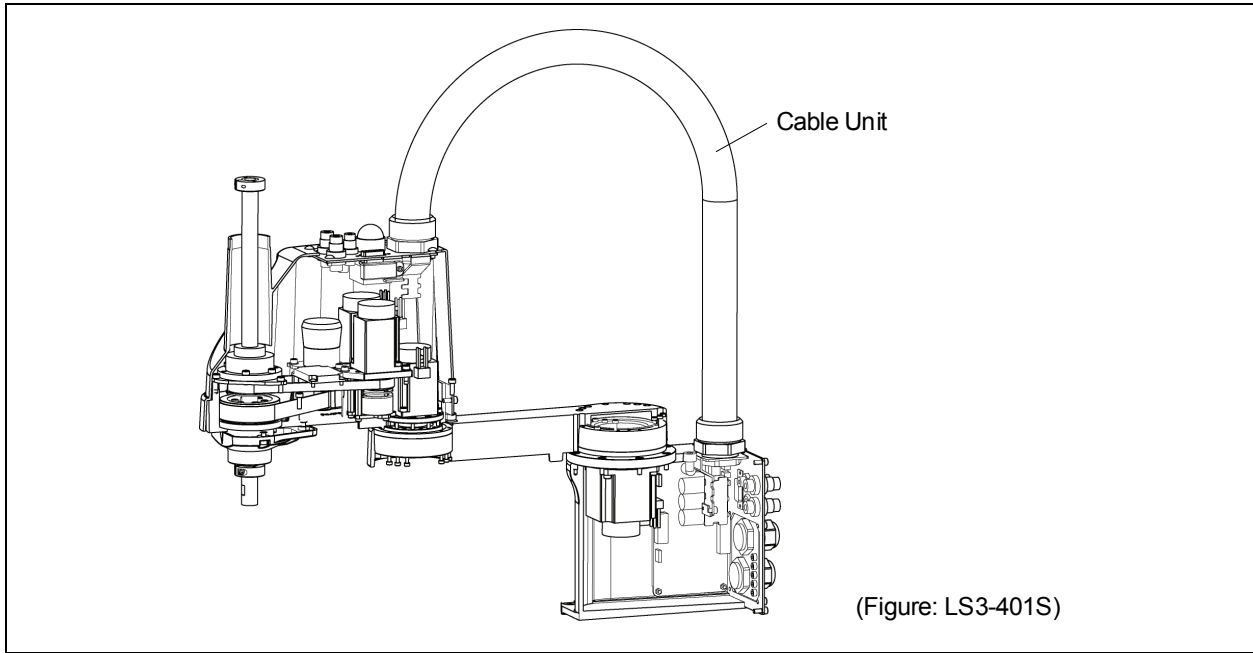

(Figure: LS3-401S)



CAUTION

- If the connectors have been disconnected during the replacement of the cable unit, be sure to reconnect the connectors to their proper positions. Refer to the block diagrams.  
Improper connection of the connectors may result in improper function of the robot system.  
For details on the connections, refer to *Maintenance: 4.2 Wiring Diagrams*.
- When installing the cover, be careful not to allow the cables to interfere with the cover mounting and do not bend these cables forcibly to push them into the cover. Unnecessary strain on cables may result in damage to the cables, disconnection, and/or contact failure. Damaged cables, disconnection, or contact failure is extremely hazardous and may result in electric shock and/or improper function of the robot system.  
When routing the cables, observe the cable locations after removing the cover. Be sure to place the cables back to their original locations.
- Be sure to connect the cables properly. Do not allow unnecessary strain on the cables. (Do not put heavy objects on the cables. Do not bend or pull the cables forcibly.) The unnecessary strain on the cables may result in damage to the cables, disconnection, and/or contact failure. Damaged cables, disconnection, or contact failure is extremely hazardous and may result in electric shock and/or improper function of the robot system.



NOTE LS3: A brake is mounted on the Joint #3 motor to prevent the shaft from lowering down due to the weight of the end effector while the power to the Controller is OFF or while the motor is in OFF status (MOTOR OFF).

LS6: A brake is mounted on the motor of Joints #3 and #4 to prevent the shaft from moving down due to the weight of the end effector while the power to the Controller is OFF or while the motor is in OFF status (MOTOR OFF).

Move the shaft down to its lower limit before the replacement procedure following the removal steps.

Cable Unit  
Removal

- (1) Turn ON the Controller and change the motor to OFF status (MOTOR OFF).
- (2) Press and hold the brake release switch to let the shaft down. Be sure to keep enough space and prevent the end effector hitting any peripheral equipment.
 

LS3: The brake release switch affects only Joint #3. When the brake release switch is pressed, the Joint #3 brake is released.  
Be careful of the shaft while the brake release switch is being pressed because the shaft may be lowered by the weight of an end effector.

LS6: The brake release switch is applied to both Joints #3 and Joint #4.  
When the brake release switch is pressed, the respective brakes of the Joint #3 and Joint #4 are released simultaneously.  
Be careful of the shaft falling and rotating while the brake release switch is being pressed because the shaft may be lowered by the weight of an end effector.
- (3) Turn OFF the Controller and disconnect the power cable and signal cable connectors from the controller.
- (4) Remove the Connector Plate.  
For details, refer to *Maintenance: 3.3 Connector Plate*.
- (5) Remove the following that connected to the Connector Plate and Connector Sub Plate.  
Air tube / D-sub cable / Connector X121, X131
- (6) Remove the ground wire that secured on the base side cable fixing plate.
- (7) Pull out the signal connector from the resolver board.



Remember the cable layout for reconnecting the cables correctly after replacement.

- (8) Cut off the wire tie binding the cables in the Base side.
- (9) Remove the Arm Top Cover.  
For details, refer to *Maintenance: 3.1 Arm Top Cover*.
- (10) Remove the User Plate.  
For details, refer to *Maintenance: 3.5 User Plate*.
- (11) Disconnect 10 connectors on the Arm side.  
X21, X31, X41, X22, X32, X33, X35, X221, X231, X241
- (12) Disconnect the D-sub cable and air tube from the User Plate.



Mounting screws for the D-sub cable are very small. Be sure to keep the screws.

Press the ring on the fittings to pull out the air tube. ( $\phi 6 \times 2$ ,  $\phi 4 \times 1$ )

Remember the cable layout for reconnecting the disconnected parts after replacement.

- (13) Remove the ground wire from the Z motor plate.
- (14) Cut off the wire tie binding the cables in the Arm side.
- (15) Remove the nut that secures the cable duct fittings to the User Plate and pull out the cables from the User Plate.

(16) Remove the nut that secures the cable duct fittings to the Base.

Remove the signal connector X20 connected to the resolver board (at the back side) and pull out the cables from the Base.

Base side

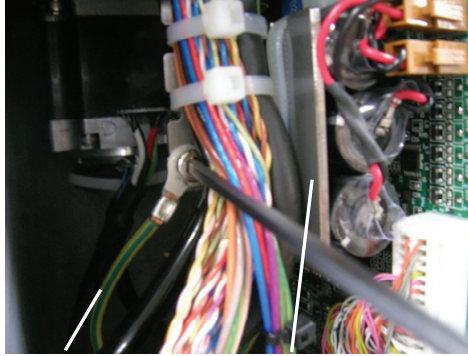

Arm #2 side

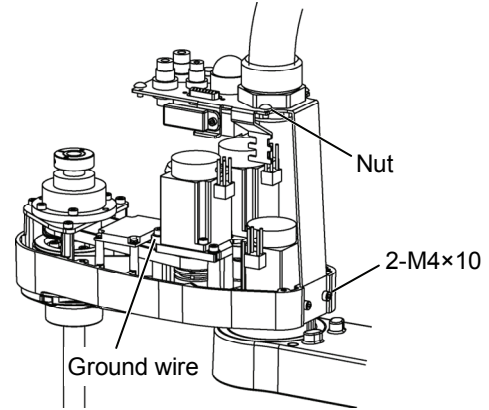



---

**Cable Unit  
Installation**

- (1) Pass the new cables through the Base, cable fixing plate, and nut.  
Secure the signal connector to the resolver board and turn the fittings to secure the Cable Unit.
- (2) Pass the cables in the User Plate side through the User Plate and nut and turn the fittings to secure the cables.
- (3) Connect the following to inner side of the Connector Plate and Connector Sub Plate.  
Air tube / D-sub cable / Connectors X121, X131
- (4) Connect the ground wire on the Base side to the cable fixing plate.
- (5) Bind the cables with a wire tie as removed in the removal step (8).
- (6) Connect the air tube and the D-sub cable to the User Plate.
- (7) Mount the User Plate.  
For the details, refer to *Maintenance: 3.5 User Plate*.
- (8) Connect the connectors X21, X31, X41, X22, X32, X33, X35, X221, X231, X241.
- (9) Mount the ground wire in the Arm side to the Z motor plate.
- (10) Bind the cables with a wire tie in their original position as before removed in the removal step (15).
- (11) Mount the Connector Plate.  
For the details, refer to *Maintenance: 3.3 Connector Plate*.
- (12) Place and secure the Arm Top Cover without the cables being stuck.  
For details, refer to *Maintenance: 3.1 Arm Top Cover*.
- (13) Execute the calibration for all joints but the Joint #1.  
If the connector falls off from the battery board, execute the calibration for all axes.  
For details, refer to *Maintenance: 13 Calibration*.

# 4.2 Wiring Diagrams

## 4.2.1 Signal Cable

LS3

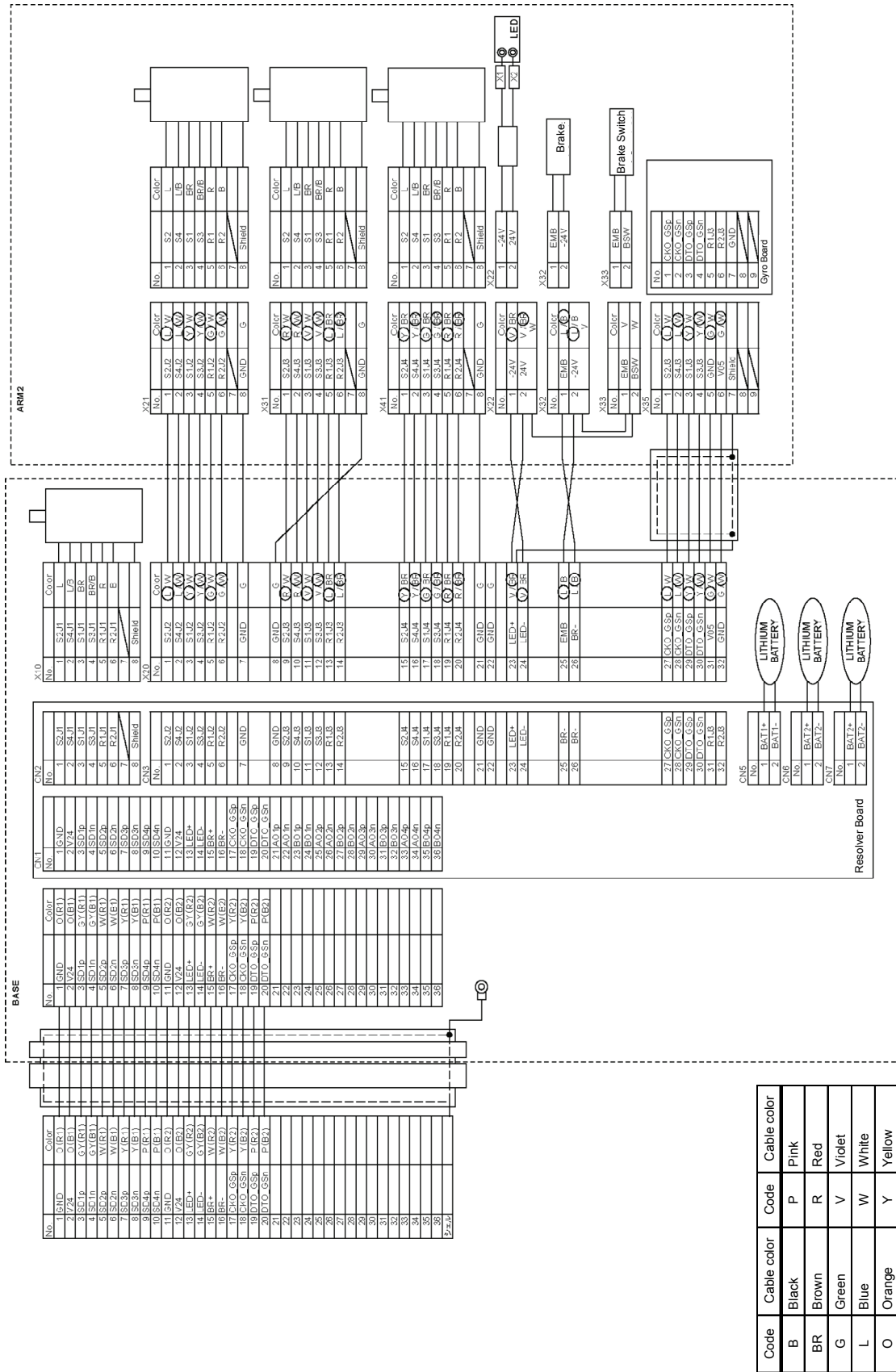

LS6

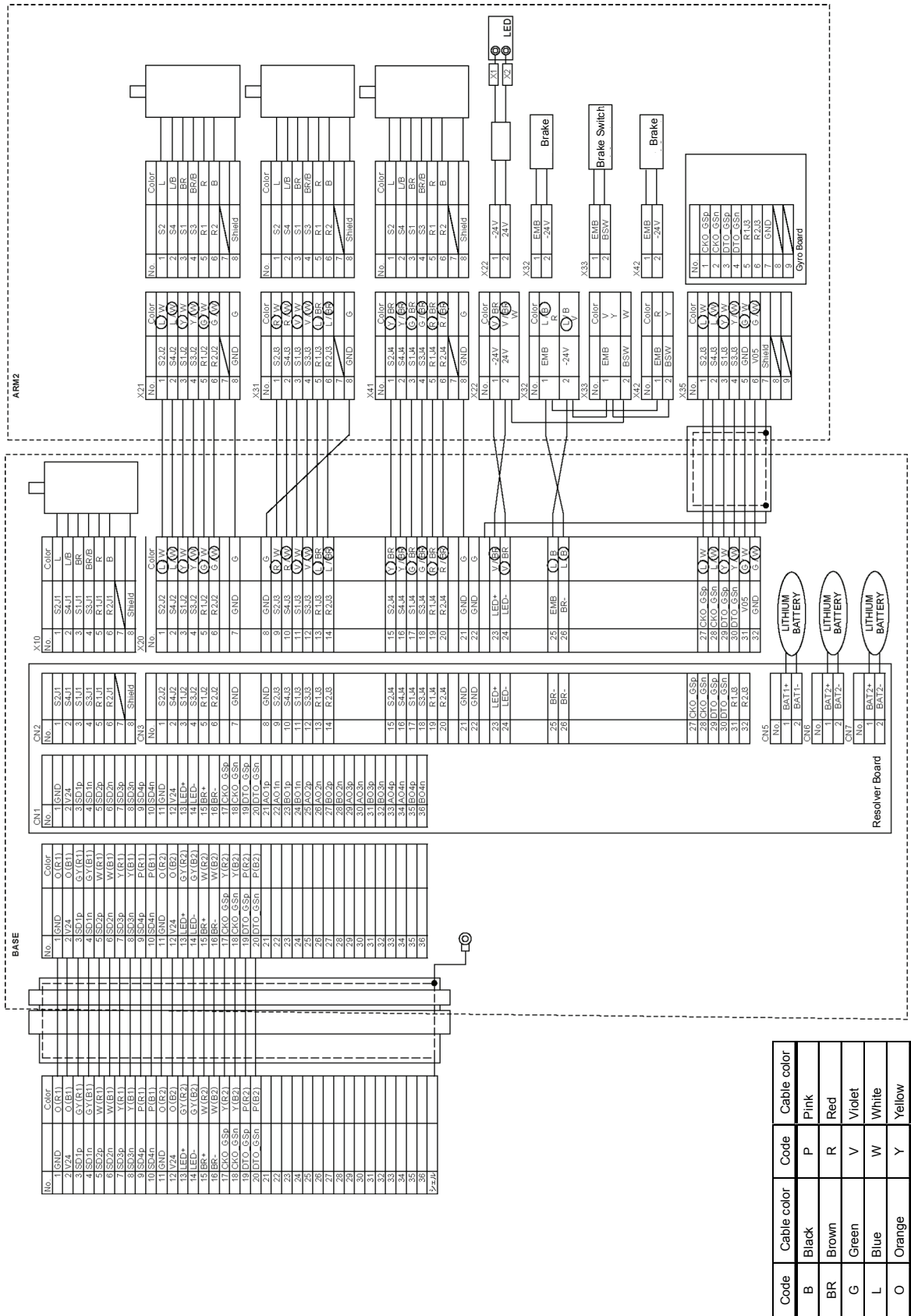

4.2.2 Power Cable

LS3/LS6

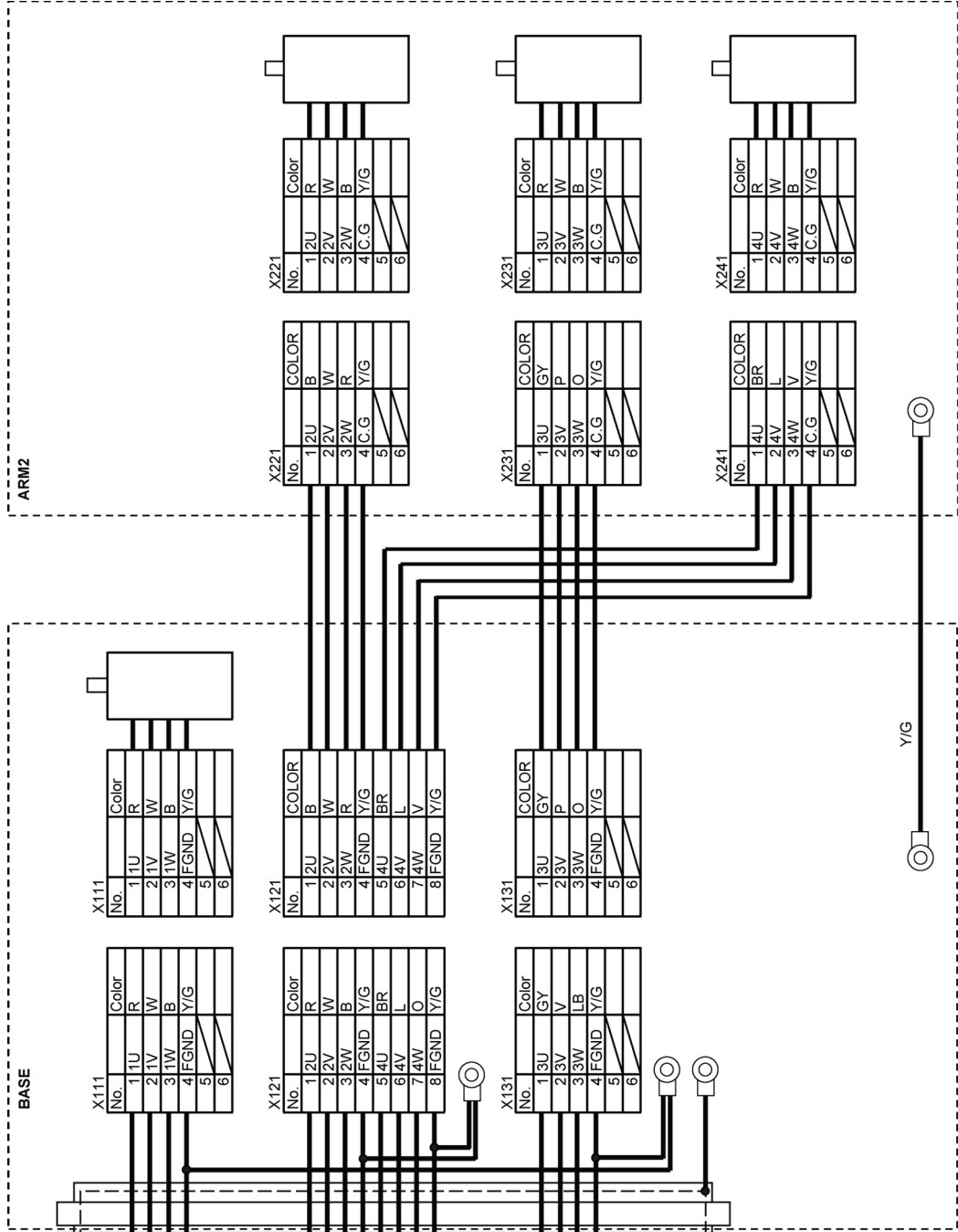

No.	Color
A1	1U R
B1	1V W
A2	1W B
B2	FGND Y/G
A3	2U R
B3	2V W
A4	2W B
B4	FGND Y/G
A7	4U BR
B7	4V L
A8	4W O
B8	FGND Y/G
A5	3U GY
B5	3V V
A6	3W LB
B6	FGND Y/G
A9	

No.	Color
11U	R
21V	W
31W	B
4FGND	Y/G
5	
6	

No.	Color
12U	R
22V	W
32W	B
4FGND	Y/G
54U	BR
64V	L
74W	O
8FGND	Y/G

No.	Color
13U	GY
23V	V
33W	LB
4FGND	Y/G
5	
6	

No.	Color
11U	R
21V	W
31W	B
4FGND	Y/G
5	
6	

No.	Color
12U	B
22V	W
32W	R
4FGND	Y/G
54U	BR
64V	L
74W	V
8FGND	Y/G

No.	Color
13U	GY
23V	P
33W	O
4FGND	Y/G
5	
6	

No.	Color
12U	B
22V	W
32W	R
4C.G	Y/G
5	
6	

No.	Color
13U	GY
23V	P
33W	O
4C.G	Y/G
5	
6	

No.	Color
14U	BR
24V	L
34W	V
4C.G	Y/G
5	
6	

No.	Color
12U	R
22V	W
32W	B
4C.G	Y/G
5	
6	

No.	Color
13U	R
23V	W
33W	B
4C.G	Y/G
5	
6	

No.	Color
14U	R
24V	W
34W	B
4C.G	Y/G
5	
6	

Code	Cable color	Code	Cable color
B	Black	P	Pink
BR	Brown	R	Red
G	Green	V	Violet
L	Blue	W	White
LG	Light green	Y	Yellow
O	Orange		

**4.2.3 User Cable**

**LS3/LS6**

D-sub 15pin

No.	Color
1	L/(W)
2	(L)/W
3	Y/(W)
4	(Y)/W
5	G/(W)
6	(G)/W
7	R/(W)
8	(R)/W
9	V/(W)
10	(V)/W
11	L/(BR)
12	(L)/BR
13	Y/(BR)
14	(Y)/BR
15	G/(BR)

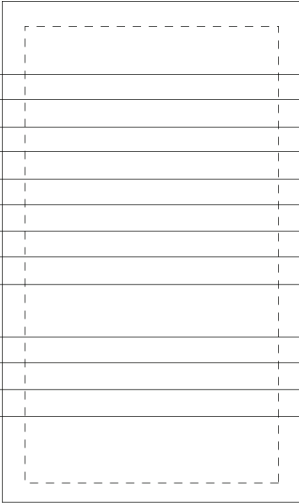

D-sub 15pin

No.	Color
1	L/(W)
2	(L)/W
3	Y/(W)
4	(Y)/W
5	G/(W)
6	(G)/W
7	R/(W)
8	(R)/W
9	V/(W)
10	(V)/W
11	L/(BR)
12	(L)/BR
13	Y/(BR)
14	(Y)/BR
15	G/(BR)

Code	Cable color	Code	Cable color
B	Black	R	Red
BR	Brown	V	Violet
G	Green	W	White
L	Blue	Y	Yellow

The following table shows the types of the use cable.

Model type	Code
Standard / Cleanroom	R13B020059

### 4.3 Replacing M/C Cable

Since the power is supplied to each motor from the lithium battery installed on the battery board via the battery connector, the position data will not be lost when the Controller is turned OFF. When the battery connectors are disconnected, the position data will be lost, and EPSON RC+ will display an error when the Controller is turned ON.



If the error occurs, execute the calibration of all joints and axes.  
For details, refer to *Maintenance: 13. Calibration*.

	Name	Quantity	Note
Maintenance parts	M/C Cable	1	3 m: R12B020453 5 m: R12B020454 10 m: R12B020455
Tools	Hexagonal wrench (width across flats: 3 mm)	1	For M4 screw
	Torque wrench	1	

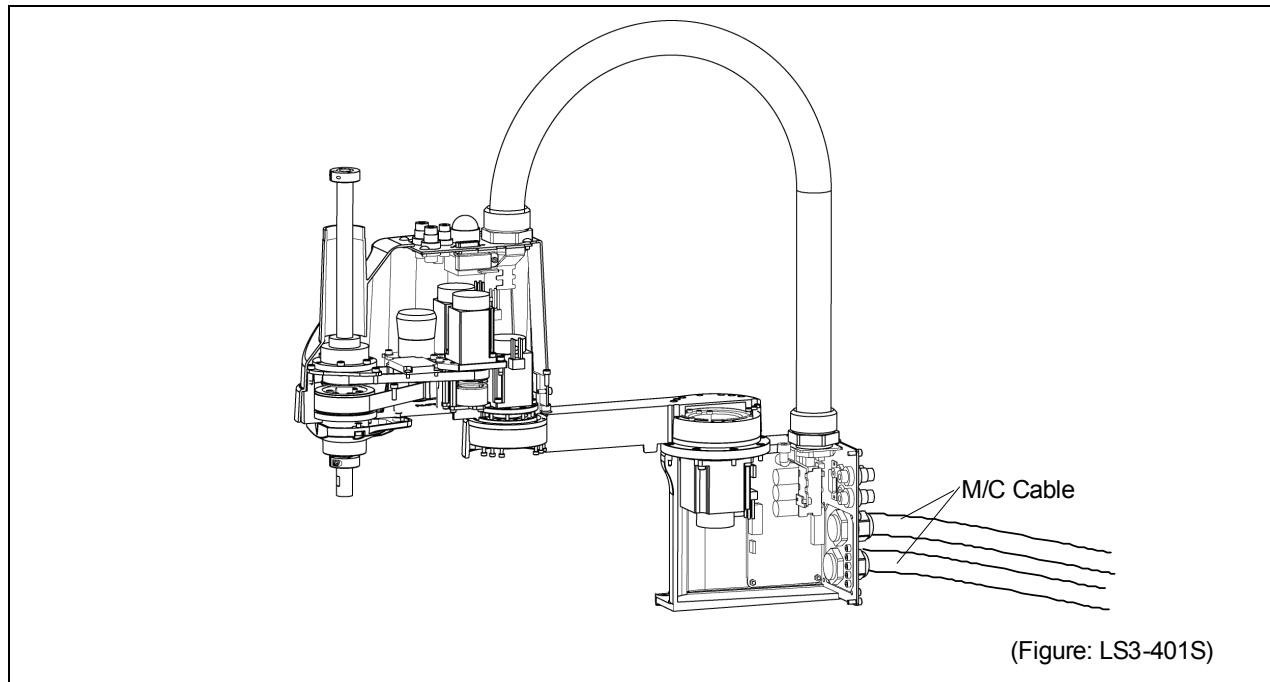

 <b>CAUTION</b>	<ul style="list-style-type: none"> <li>■ If the connectors have been disconnected during the replacement of the cable unit, be sure to reconnect the connectors to their proper positions. Refer to the block diagrams. Improper connection of the connectors may result in improper function of the robot system. For details on the connections, refer to <i>Maintenance: 4.2 Wiring Diagrams</i>.</li> <li>■ When installing the cover, be careful not to allow the cables to interfere with the cover mounting and do not bend these cables forcibly to push them into the cover. Unnecessary strain on cables may result in damage to the cables, disconnection, and/or contact failure. Damaged cables, disconnection, or contact failure is extremely hazardous and may result in electric shock and/or improper function of the robot system. When routing the cables, observe the cable locations after removing the cover. Be sure to place the cables back to their original locations.</li> <li>■ Be sure to connect the cables properly. Do not allow unnecessary strain on the cables. (Do not put heavy objects on the cables. Do not bend or pull the cables forcibly.) The unnecessary strain on the cables may result in damage to the cables, disconnection, and/or contact failure. Damaged cables, disconnection, or contact failure is extremely hazardous and may result in electric shock and/or improper function of the robot system.</li> </ul>
---	--

#### M/C Cable Removal

- (1) Turn OFF the Controller.
- (2) Disconnect the power cable and signal cable connectors from the controller.
- (3) Remove the Connector Plate.

For details, refer to *Maintenance: 3.3 Connector Plate*.

#### NOTE



Do not pull the plate forcibly.

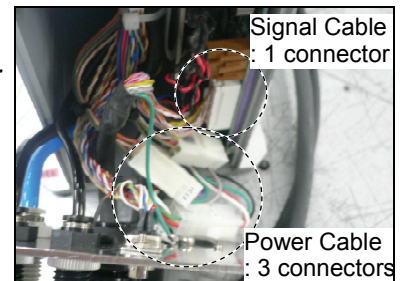

- (4) Disconnect the connectors.

Each connector has a unique number.  
Each connector has a different shape.

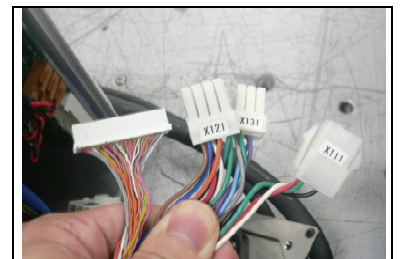

- (5) Remove the Connector Sub Plate.

For details, refer to *Maintenance: 3.4 Connector Sub Plate*.

The M/C cables are still attached to the plate.

M/C Cable  
Installation

- (6) Install the Connector Sub Plate with the new M/C Cable to the Connector Plate.  
For details, refer to *Maintenance: 3.4 Connector Sub Plate*.
- (7) Connect the connectors. (Connect to the Cable Unit with the same number.)
- (8) Mount the Connector Plate.  
For details, refer to *Maintenance: 3.3 Connector Plate*.
- (9) Connect the power cable and signal cable connectors to the controller.
- (10) Turn ON the Controller.
- (11) If the connector falls off from the battery board, execute the calibration for all axes.  
For details, refer to *Maintenance: 13 Calibration*.



## 5. Arm #1



- Do not insert or pull out the motor connectors while the power to the robot system is turned ON. Inserting or pulling out the motor connectors with the power ON is extremely hazardous and may result in serious bodily injury as the Manipulator may move abnormally, and also may result in electric shock and/or malfunction of the robot system.
- To shut off power to the robot system, pull out the power plug from the power source. Be sure to connect the AC power cable to a power receptacle. DO NOT connect it directly to a factory power source.
- Before performing any replacement procedure, turn OFF the Controller and related equipment, and then pull out the power plug from the power source. Performing any replacement procedure with the power ON is extremely hazardous and may result in electric shock and/or malfunction of the robot system.



- Be careful not to apply excessive shock to the motor shaft when replacing the motors. The shock may shorten the life cycle of the motors and encoder and/or damage them.
- Never disassemble the motor and encoder. A disassembled motor and encoder will cause a positional gap and cannot be used again.

After parts have been replaced (motors, reduction gear units, brakes, timing belts, ball screw spline unit, etc.), the Manipulator cannot operate properly because a mismatch exists between the origin stored in each motor and its corresponding origin stored in the Controller.

After replacing the parts, it is necessary to match these origins.

The process of aligning the two origins is called “Calibration”.

Refer to *Maintenance: 13. Calibration* to execute the calibration.

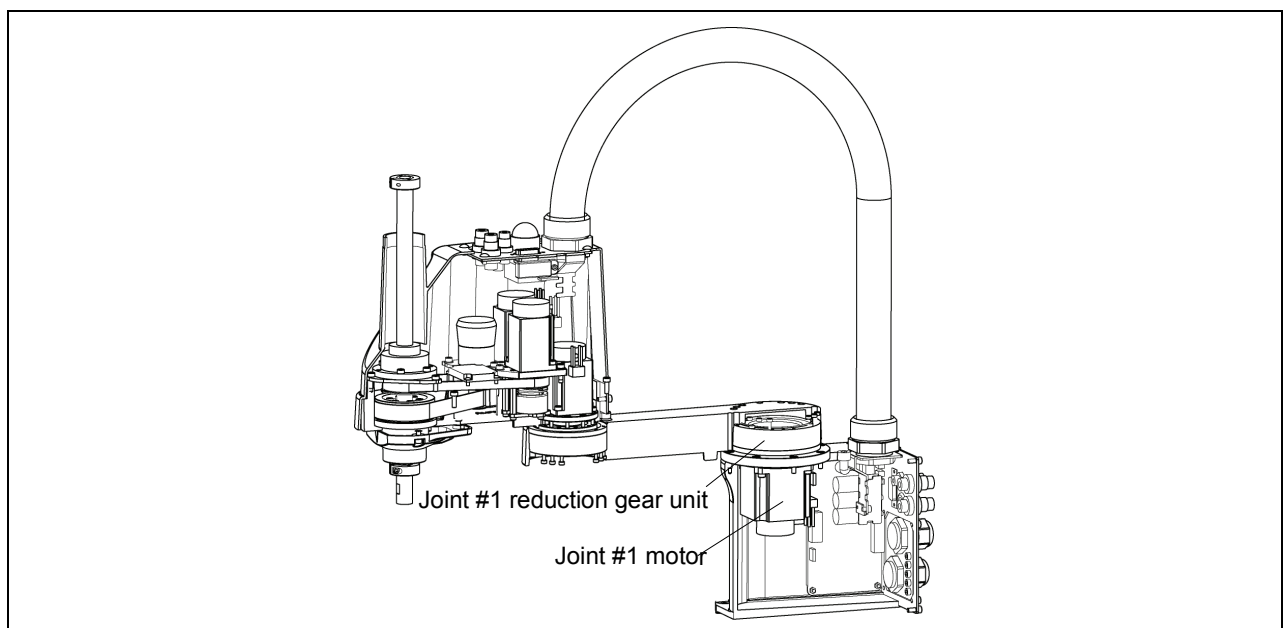

## 5.1 Replacing Joint #1 Motor

	Name	Quantity	Note
Maintenance parts	AC Servo Motor (200 W)	1	R13B000102
	Grease (SK-1A)	-	R13ZA00330100
Tools	Hexagonal wrench (width across flats: 2 mm)	1	For M4 set screw
	Hexagonal wrench (width across flats: 3 mm)	1	For M4 screw
	Torque wrench	1	
	Wiping cloth	1	For wiping grease

Joint #1 motor (1) Remove the Connector Plate.

### Removal

For details, refer to *Maintenance: 3.3 Connector Plate*.

- (2) Disconnect the connector X111. (Hold the claw to remove.)
- (3) Remove the Arm #1 mounting bolt in the Joint #1 side and remove the arm.

There is an O-ring between the Joint #1 unit and the arm. Be sure to keep the O-ring.

- (4) Remove the screws mounting the Joint #1 flange on the Base.

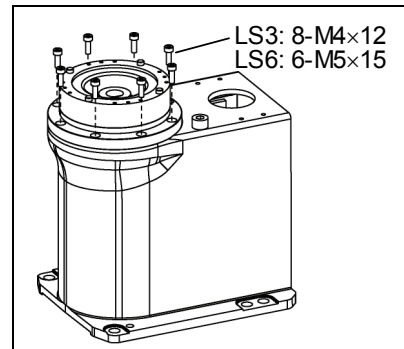

- (5) Hold up the Joint #1 unit and remove the connector X10 from the resolver board.

- (6) LS3: Loosen the motor mounting screws on the Joint #1 motor flange and remove the motor unit

There is an O-ring in the assembly position of the motor and Joint #1 flange. Be sure to keep the O-ring.

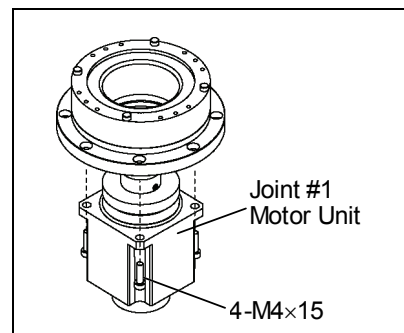

- LS6: Loosen the motor flange mounting screws on the Joint #1 motor flange and remove the motor unit

There is an O-ring in the assembly position of the motor and Joint #1 flange. Be sure to keep the O-ring.

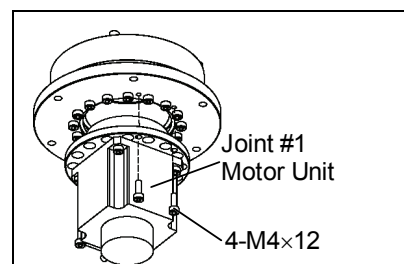

- (7) Remove the waveform generator from the Joint #1 motor.

There is a brass bushing in one of the set screw holes. Be sure to keep the bushing.

A: Brass Bushing LS3: M4

LS6: M5

B: Set Screw LS3: 2-M4×6

LS6: 2-M5×6

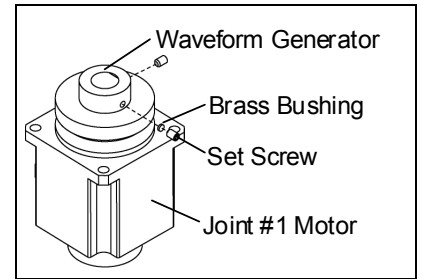

- (8) Only LS6

Remove the motor mounting screws and then remove the motor flange and O-ring.



LS3 does not have a motor flange.

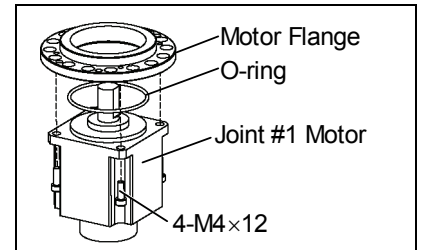

Joint #1 motor  
Installation

(1) Only LS6

Put the O-ring on the motor mounting surface and mount the motor flange.



LS3 does not have a motor flange.

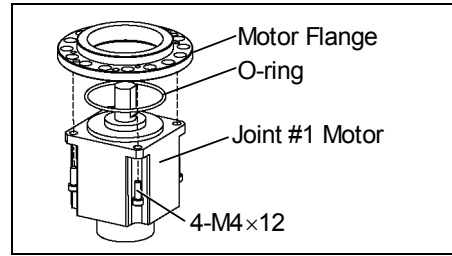

(2) Apply grease (SK-1A) to the between the waveform generator and motor.

Grease volume LS3: 4 g  
LS6: 13 g

Mount the waveform generator on the Joint #1 motor.

Be sure to align the end face of the waveform generator to the end face of the motor shaft.

Tighten one of the set screws vertically on the flat face of the motor shaft. Insert a bushing into the other set screw hole to prevent damage to the motor shaft.

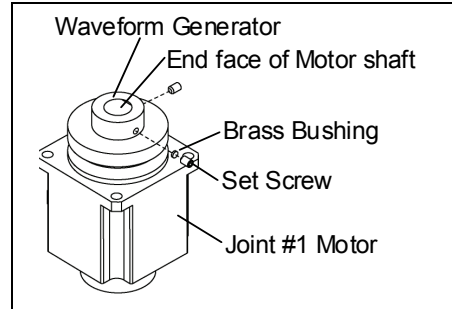

- A: Brass Bushing LS3: M4  
LS6: M5
- B: Set Screw LS3: 2-M4x6  
LS6: 2-M5x6



■ See the figure above for the orientation of the waveform generator. Be sure to install the waveform generator properly. Improper installation of the waveform generator will result in improper function of the Manipulator.

(3) LS3: Set an O-ring on the motor mounting surface and assemble the motor with the Joint #1 flange.

LS6: Set an O-ring on the motor flange and assemble the motor with the Joint #1 flange.

To insert the motor, turn it slowly from side to side by hand and push in.

(4) Connect the connector X10 to the resolver board.

(5) Mount the Joint #1 unit on the Base.

Secure the Joint #1 motor cables facing toward the back of the Base.

(6) Set the O-ring removed in the removal step (3) into the O-ring groove of the arm.

Then, mount the arm to the Joint #1 unit.

(7) Connect the connector X110.

(8) Mount the Connector Plate.

For details, refer to *Maintenance: 3.3 Connector Plate*.

(9) Execute the calibration for the Joint #1.

For details refer to *Maintenance: 13. Calibration*.

## 5.2 Replacing Joint #1 Reduction Gear Unit

A reduction gear unit consists of the following three parts. When replacing the reduction gear unit, be sure to always replace the waveform generator, flexspline, and circular spline all together as one set.

Waveform generator / Flexspline / Circular spline

For details of the reduction gear unit, refer to *Maintenance: 14. Maintenance Parts List*.

	Name		Quantity	Note
Maintenance Parts	Reduction Gear Unit	SHF20-50	1	LS3-401*: R13B010039
		SHF25-80		LS6-602*: R13B010041
	Grease	SK-1A	-	R13ZA00330100
Tools	Hexagonal wrench (width across flats: 2 mm)		1	For M4 set screw
	Hexagonal wrench (width across flats: 2.5 mm)		1	For M3 screw
	Hexagonal wrench (width across flats: 3 mm)		1	For M4 screw
	Torque wrench		1	
	Nippers		1	
	Spatula		1	For apply grease
	Wiping cloth		1	For wiping grease (Flange)
			1	For wiping grease (Bolt)
Screw (M4)		2	About 20 mm in length For flexspline removal	

### Joint #1 Reduction Gear Unit Removal

- (1) Remove the Joint #1 motor unit.

Follow the removal steps in *Maintenance: 5.1 Replacing Joint #1 Motor*.

- (2) Remove the reduction gear unit from the Joint #1 flange.

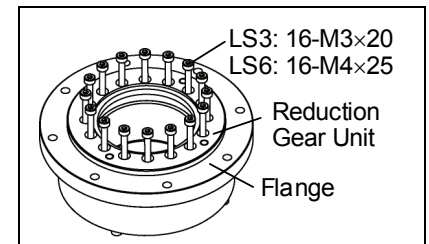

Joint #1  
Reduction  
Gear Unit  
Installation

- (1) A new reduction gear unit contains the parts shown in the picture on the right when it is unpacked.

The gear grooves of the flexspline, circular spline, and the bearings of the waveform generator have been greased. Wipe off excess grease from the mounting surface.

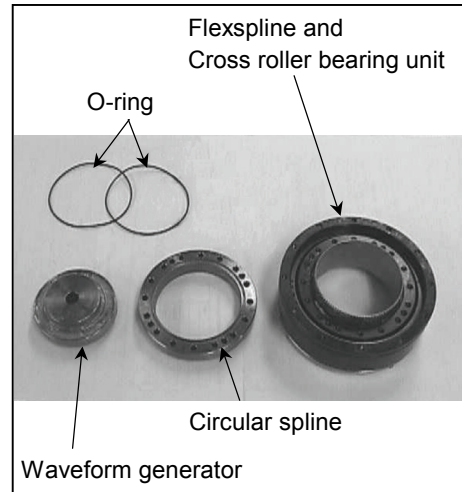

- Never adjust (loosen or tighten) the mounting bolts between the flexspline and cross roller bearing unit. If the mounting bolts are adjusted, the flexspline and cross roller bearing unit must be aligned by the maker of the reduction gear unit.

- (2) Fit the O-rings into the grooves on both sides of the new circular spline.

Make sure that the rings do not come out of the grooves.

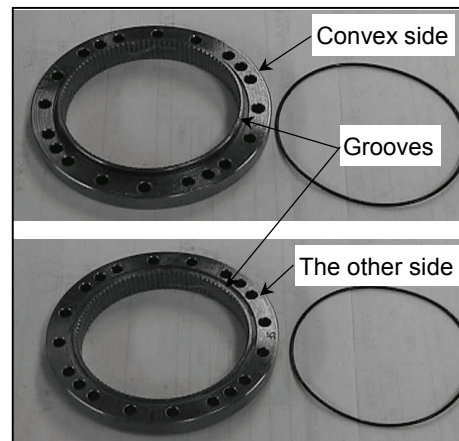

- (3) Face the convex side of the circular spline down, and then fit it into the flexspline.



- (4) Match the screw holes on the inner ring of the cross roller bearing unit and the through holes of the circular spline.

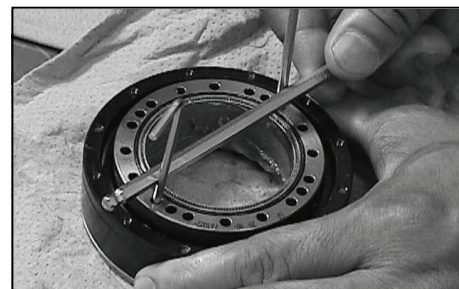

- (5) Secure the reduction gear flange to the circular spline.

Loosely fasten all bolts in a crisscross pattern so that the bolts will be fastened evenly. Then, using a torque wrench, tighten each bolt securely in a crisscross pattern at the torque specified in the table below.

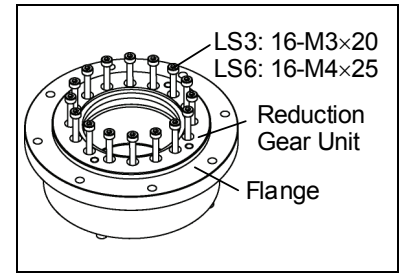

Item	Manipulator type	Bolt type	Bolts	Tightening torque
Joint #1 reduction gear unit	LS3	M3×20	16	300 N·cm (30.6 kgf·cm)
	LS6	M4×25	16	600 N·cm (61.2 kgf·cm)

NOTE  

Be careful not to apply too much force since it may damage the parts.

- (6) Apply grease (SK-1A) inside the flexspline.

Grease volume LS3: 19 g

LS6: 37 g

- (7) Mount the Joint #5 motor.

Follow the installation steps in *Maintenance: 5.1 Replacing Joint #1 Motor*.

## 6. Arm #2

 <p>WARNING</p>	<ul style="list-style-type: none"><li>■ Do not insert or pull out the motor connectors while the power to the robot system is turned ON. Inserting or pulling out the motor connectors with the power ON is extremely hazardous and may result in serious bodily injury as the Manipulator may move abnormally, and also may result in electric shock and/or malfunction of the robot system.</li><li>■ To shut off power to the robot system, pull out the power plug from the power source. Be sure to connect the AC power cable to a power receptacle. DO NOT connect it directly to a factory power source.</li><li>■ Before performing any replacement procedure, turn OFF the Controller and related equipment, and then pull out the power plug from the power source. Performing any replacement procedure with the power ON is extremely hazardous and may result in electric shock and/or malfunction of the robot system.</li></ul>
--	---

 <p>CAUTION</p>	<ul style="list-style-type: none"><li>■ Be careful not to apply excessive shock to the motor shaft when replacing the motors. The shock may shorten the life cycle of the motors and encoder and/or damage them.</li><li>■ Never disassemble the motor and encoder. A disassembled motor and encoder will cause a positional gap and cannot be used again.</li></ul>
--	--

After parts have been replaced (motors, reduction gear units, brakes, timing belts, ball screw spline unit, etc.), the Manipulator cannot operate properly because a mismatch exists between the origin stored in each motor and its corresponding origin stored in the Controller.

After replacing the parts, it is necessary to match these origins.

The process of aligning the two origins is called “Calibration”.

Refer to *Maintenance: 13. Calibration* to execute the calibration.

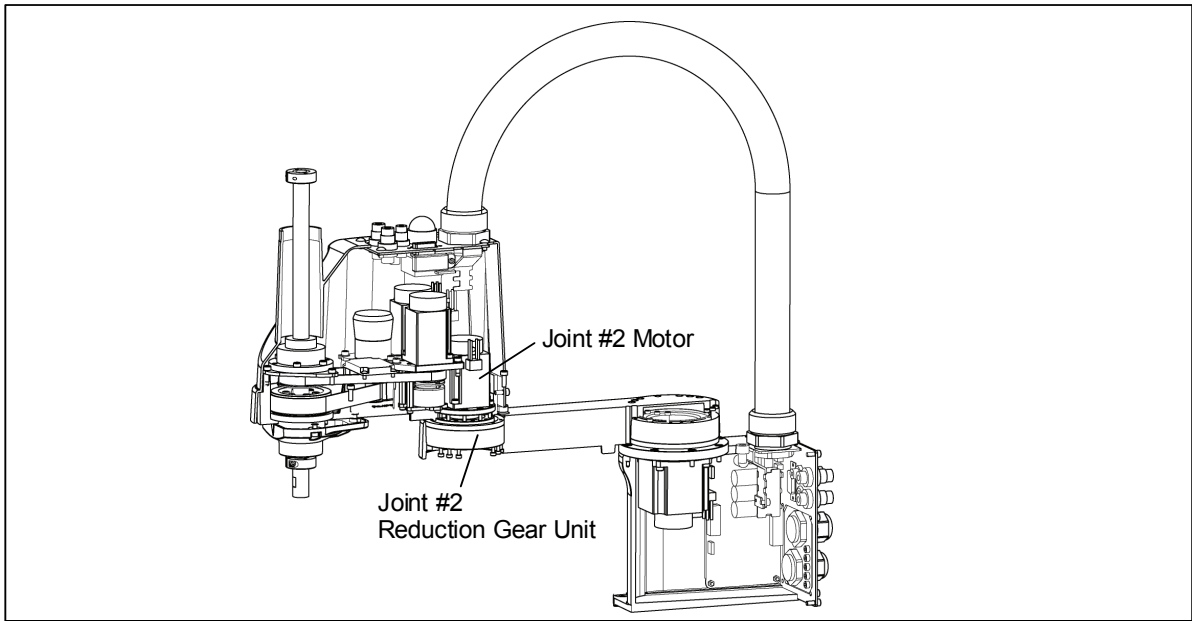



## 6.1 Replacing Joint #2 Motor

	Name	Quantity	Note
Maintenance Parts	AC Servo Motor	100W	LS3-401*: R13B000101
		200W	LS6-602*: R13B000102
	Grease	SK-2	LS3-401*: R13ZA00330400
		SK-1A	LS6-602*: R13ZA00330100
Tools	Hexagonal wrench (width across flats: 2 mm)		1 For M4 set screw
	Hexagonal wrench (width across flats: 3 mm)		1 For M4 screw
	Torque wrench		1
	Nippers		1 For cutting wire tie
	Wiping cloth		1 For wiping grease
Material	Wire tie	-	



LS3: A brake is mounted on the Joint #3 motor to prevent the shaft from lowering down due to the weight of the end effector while the power to the Controller is OFF or while the motor is in OFF status (MOTOR OFF).

LS6: A brake is mounted on the motor of Joints #3 and #4 to prevent the shaft from moving down due to the weight of the end effector while the power to the Controller is OFF or while the motor is in OFF status (MOTOR OFF).

Move the shaft down to its lower limit before the replacement procedure following the removal steps.

### Joint #2 Motor Removal

- (1) Turn ON the Controller.
- (2) Push down the shaft to its lower limit while pressing the brake release switch. Be sure to keep enough space and prevent the end effector hitting any peripheral equipment.

LS3: The brake release switch affects only Joint #3. When the brake release switch is pressed, the Joint #3 brake is released.

Be careful of the shaft while the brake release switch is being pressed because the shaft may be lowered by the weight of an end effector.

LS6: The brake release switch is applied to both Joints #3 and Joint #4.

When the brake release switch is pressed, the respective brakes of the Joint #3 and Joint #4 are released simultaneously.

Be careful of the shaft falling and rotating while the brake release switch is being pressed because the shaft may be lowered by the weight of an end effector.

- (3) Turn OFF the Controller.
- (4) Remove the Arm Top Cover.

For details, refer to *Maintenance: 3.1 Arm Top Cover*.

- (5) Remove the User Plate.

For details, refer to *Maintenance: 3.5 User Plate*.

- (6) Cut off the wire tie binding the cables.

At this point, do not cut the wire tie (in the duct fittings outlet) that binds the cables to the User Plate.

- (7) Disconnect the connectors X221 and X21. (Hold the claw to remove.)

- (8) Remove the screws mounting the motor unit and then remove the Joint #2 motor unit from the Arm #2.

LS3: Motor flange mounting screw 3-M4×10

LS6: Motor mounting screw 4-M4×12

To pull out the motor smoothly, move the Arm #2 slowly by hand while pulling the motor.

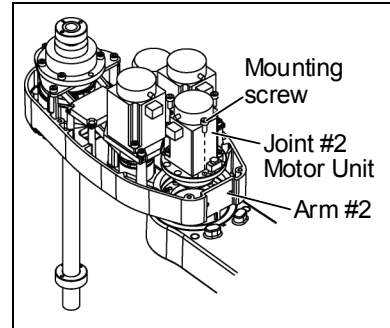

- (9) Remove the waveform generator from the Joint #2 motor.

There is a brass bushing in one of the set screw holes. Be sure to keep the bushing.

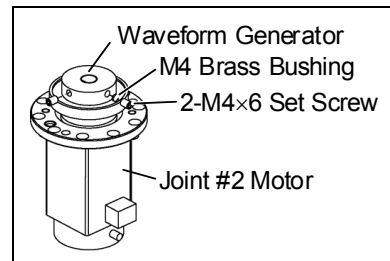

- (10) Only LS3

Remove the motor flange from the Joint #2 motor.



LS6 does not have a motor flange.

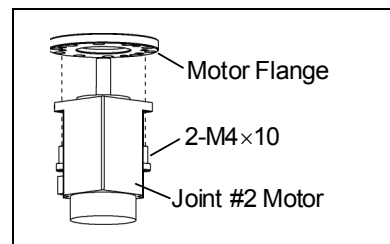

### Joint #2 Motor Installation

- (1) Only LS3

Mount the motor flange on the Joint #2 motor.



LS6 does not have a motor flange.

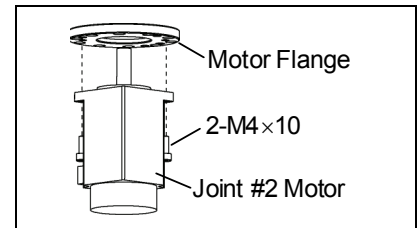

- (2) Mount the waveform generator on the Joint #2 motor.

Be sure to align the end face of the waveform generator to the end face of the motor shaft.

Tighten one of the set screws vertically on the flat face of the motor shaft. Insert a bushing into the other set screw hole to prevent damage to the motor shaft.

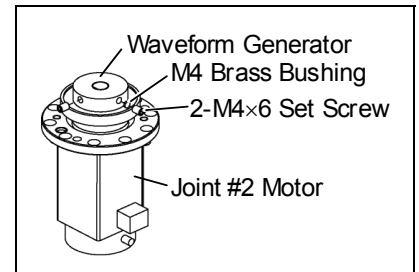

- See the figures above for the orientation of the waveform generator. Be sure to install the waveform generator properly. Improper installation of the waveform generator will result in improper function of the Manipulator.

- (3) Apply grease between the waveform generator and motor flange.

Grease volume LS3: 4 g (SK-2)

LS6: 6 g (SK-1A)

- (4) Mount the Joint #2 motor unit on the Arm #2.

To insert the motor, slowly move the Arm #2 by hand and push in.

LS3: Motor flange mounting screw 3-M4x10

LS6: Motor mounting screw 4-M4x12

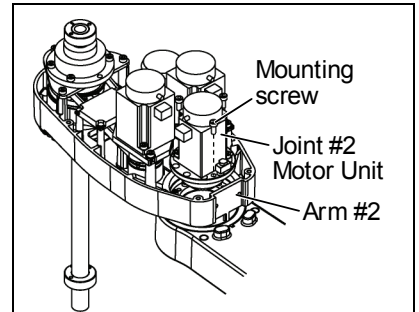

- (5) Mount the User Plate.

For details, refer to *Maintenance: 3.5 User Plate*.

- (6) Connect the connectors X221, X21.

- (7) Bind the cables with a wire tie in their original positions as before removed in the removal step (6).

Do not allow unnecessary strain on the cables.

- (8) Mount the Arm Top Cover.

For details, refer to *Maintenance: 3.1 Arm Top Cover*.

- (9) Execute the calibration for Joint #2.

For details refer to *Maintenance: 13. Calibration*.

## 6.2 Replacing Joint #2 Reduction Gear Unit

A reduction gear unit consists of the following three parts. When replacing the reduction gear unit, be sure to always replace the waveform generator, flexspline, and circular spline all together as one set.

Waveform generator / Flexspline / Circular spline

For details of the reduction gear unit, refer to *Maintenance: 14. Maintenance parts list.*

	Name		Quantity	Note
Maintenance parts	Reduction Gear Unit	SHF17-50	1	LS3-401*: R13B010040
		SHF20-50		LS6-602*: R13B010039
	Grease	SK-2	-	LS3-401*: R13ZA00330400
		SK-1A	-	LS6-602*: R13ZA00330100
	Hexagonal wrench (width across flats: 2 mm)		1	For M4 set screw
	Hexagonal wrench (width across flats: 2.5 mm)		1	For M3 screw
	Hexagonal wrench (width across flats: 3 mm)		1	For M4 screw
	Torque wrench		1	
	Spatula		1	For apply grease
	Wiping cloth		1	For wiping grease (Flange)
			1	For wiping grease (Bolt)
	Screw (M3) Length about 20 mm		2	For removing the flexspline
Material	Wire tie		-	

NOTE



LS3: A brake is mounted on the Joint #3 motor to prevent the shaft from lowering down due to the weight of the end effector while the power to the Controller is OFF or while the motor is in OFF status (MOTOR OFF).

LS6: A brake is mounted on the motor of Joints #3 and #4 to prevent the shaft from moving down due to the weight of the end effector while the power to the Controller is OFF or while the motor is in OFF status (MOTOR OFF).

Move the shaft down to its lower limit before the replacement procedure following the removal steps.

Joint #2  
Reduction  
Gear Unit  
Removal

- (1) Turn ON the Controller.
- (2) Push down the shaft to its lower limit while pressing the brake release switch. Be sure to keep enough space and prevent the end effector hitting any peripheral equipment.

LS3: The brake release switch affects only Joint #3. When the brake release switch is pressed, the Joint #3 brake is released.

Be careful of the shaft while the brake release switch is being pressed because the shaft may be lowered by the weight of an end effector.

LS6: The brake release switch is applied to both Joints #3 and Joint #4.

When the brake release switch is pressed, the respective brakes of the Joint #3 and Joint #4 are released simultaneously.

Be careful of the shaft falling and rotating while the brake release switch is being pressed because the shaft may be lowered by the weight of an end effector.

- (3) Turn OFF the Controller.
- (4) Remove the waveform generator from the Joint #2 motor.

Follow the removal steps in *Maintenance: 6.1 Replacing Joint #2 Motor*.

- (5) Remove the Arm #2 by removing the screws mounting the Arm #2 on the reduction gear unit.

A: LS3: 10-M3×18  
LS6: 16-M3×28

B: LS3: 8-M3×30+8-M3 small washer  
LS6: 8-M3×32+8-M3 small washer

C: LS3: 4-M3×15+4-M3 small washer  
LS6: 4-M3×12+4-M3 small washer

- (6) Remove the reduction gear unit from the Arm #1 by removing the screws that mounts the reduction gear unit on the Arm #1.

There is an O-ring between the Arm #1 and the reduction gear unit. Be sure to keep the O-ring.

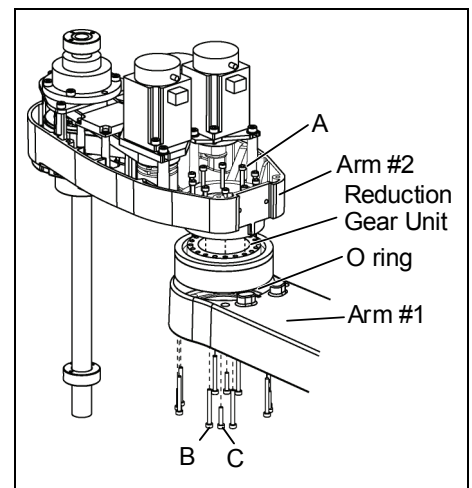

Joint #2  
Reduction  
Gear Unit  
Installation

- (1) A new reduction gear unit contains the parts shown in the picture on the right when it is unpacked.

The gear grooves of the flexspline, circular spline, and the bearings of the waveform generator have been greased. Wipe off excess grease from the mounting surface.

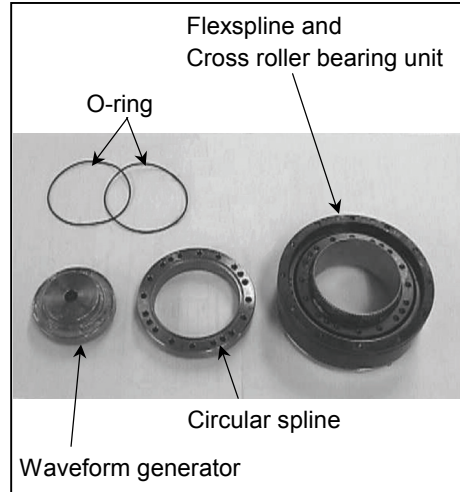

- Never adjust (loosen or tighten) the mounting bolts between the flexspline and cross roller bearing unit. If the mounting bolts are adjusted, the flexspline and cross roller bearing unit must be aligned by the maker of the reduction gear unit.

- (2) Fit the O-rings into the grooves on both sides of the new circular spline.

Make sure that the rings do not come out of the grooves.

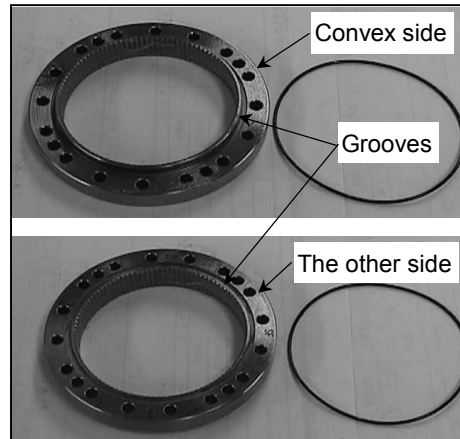

- (3) Face the convex side of the circular spline down, and then fit it into the flexspline.



- (4) Match the screw holes on the inner ring of the cross roller bearing unit and the through holes of the circular spline.

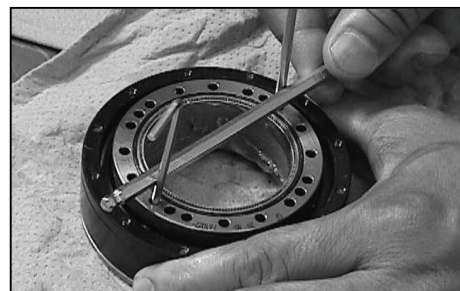

- (5) Set the O-ring removed in the removal step (6) into the O-ring groove of the Arm #1 and install the flexspline on the Arm #1.

A: LS3: 10-M3×18  
LS6: 16-M3×28

B: LS3: 8-M3×30+8-M3 small washer  
LS6: 8-M3×32+8-M3 small washer

C: LS3: 4-M3×15+4-M3 small washer  
LS6: 4-M3×12+4-M3 small washer

Loosely secure all bolts in a crisscross pattern so that the bolts will be secured evenly. Then, using a torque wrench, tighten each bolt securely in a crisscross pattern at the torque specified in the table below.

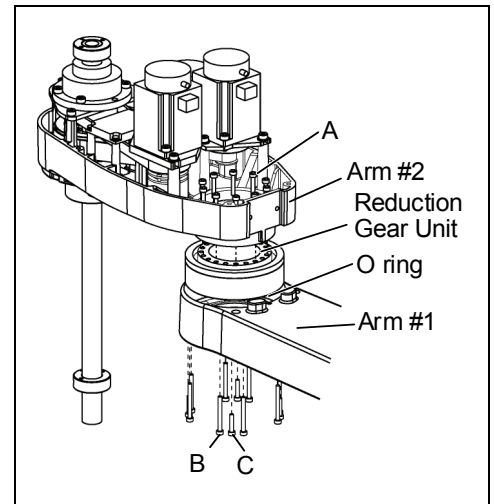

Item	Bolt type	Tightening torque
Joint #2 reduction gear unit	M3	300 N·cm (30.6 kgf·cm)



Be careful not to apply too much force since it may damage the parts

- (6) Apply grease between the motor flange and waveform generator and next inside the flexspline.

Grease volume Between the motor flange and waveform generator

LS3: 4 g (SK-2)

LS6: 6 g (SK-1A)

Inside the flexspline

LS3: 11 g (SK-2)

LS6: 16 g (SK-1A)

- (7) Set the attached O-ring into the O-ring groove of the circular spline.

Secure the Arm #2 on the circular spline.

- (8) Mount and Joint #2 motor.

Follow the installation steps in *Maintenance: 6.1 Replacing Joint #2 Motor*.

## 7. Arm #3

 <p>WARNING</p>	<ul style="list-style-type: none"><li>■ Do not insert or pull out the motor connectors while the power to the robot system is turned ON. Inserting or pulling out the motor connectors with the power ON is extremely hazardous and may result in serious bodily injury as the Manipulator may move abnormally, and also may result in electric shock and/or malfunction of the robot system.</li><li>■ To shut off power to the robot system, pull out the power plug from the power source. Be sure to connect the AC power cable to a power receptacle. DO NOT connect it directly to a factory power source.</li><li>■ Before performing any replacement, turn OFF the Controller and related equipment, and then pull out the power plug from the power source. Performing any replacement with the power ON is extremely hazardous and may result in electric shock and/or malfunction of the robot system.</li></ul>
--	---

 <p>CAUTION</p>	<ul style="list-style-type: none"><li>■ Be careful not to apply excessive shock to the motor shaft when replacing the motors. The shock may shorten the life cycle of the motors and encoder and/or damage them.</li><li>■ Never disassemble the motor and encoder. A disassembled motor and encoder will cause a positional gap and cannot be used again.</li></ul>
--	--

After parts have been replaced (motors, reduction gear units, brakes, timing belts, ball screw spline unit, etc.), the Manipulator cannot operate properly because a mismatch exists between the origin stored in each motor and its corresponding origin stored in the Controller.

After replacing the parts, it is necessary to match these origins.

The process of aligning the two origins is called “Calibration”.

Refer to *Maintenance: 13. Calibration* to execute the calibration.

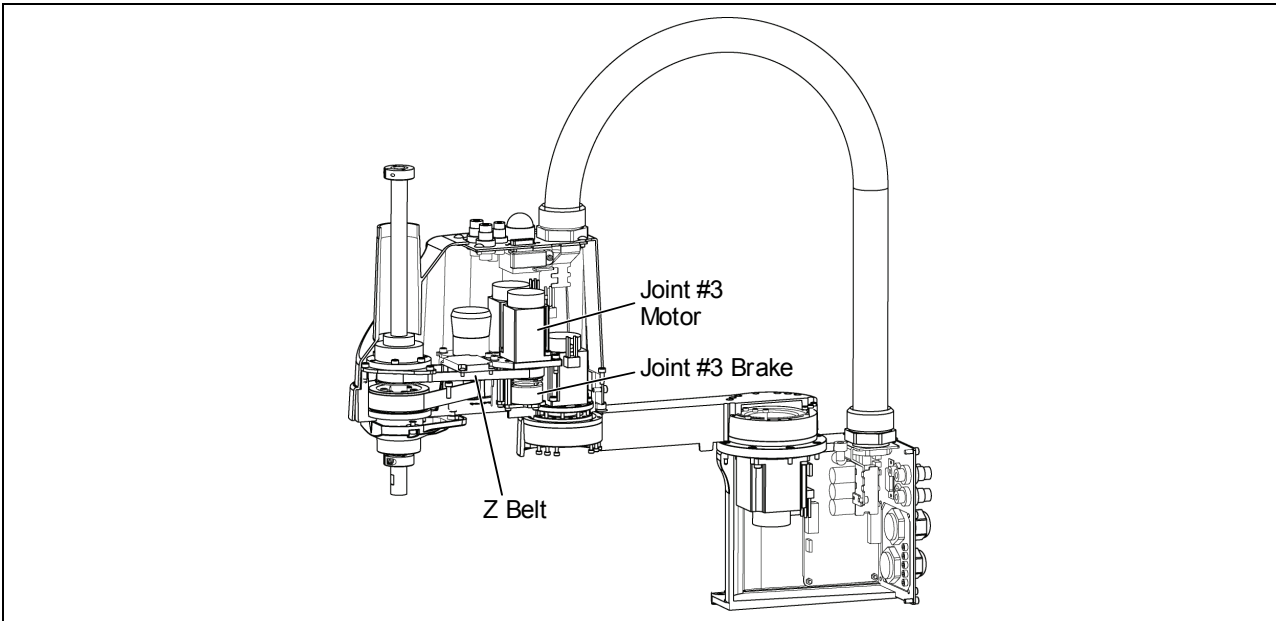



## 7.1 Replacing Joint #3 Motor

	Name	Quantity	Note
Maintenance parts	AC Servo Motor (100W)	1	R13B000101
Tools	Hexagonal wrench (width across flats: 2.5 mm)	1	For M5 set screw
	Hexagonal wrench (width across flats: 3 mm)	1	For M4 screw
	Torque wrench	1	
	Nippers	1	For cutting wire tie
	Force gauge	1	Belt tension 69 N (7.0 ± 0.5 kgf·cm)
	Suitable cord (Length about 800 mm)	1	For belt tension
Material	Wire tie	-	



LS3: A brake is mounted on the Joint #3 motor to prevent the shaft from lowering down due to the weight of the end effector while the power to the Controller is OFF or while the motor is in OFF status (MOTOR OFF).

LS6: A brake is mounted on the motor of Joints #3 and #4 to prevent the shaft from moving down due to the weight of the end effector while the power to the Controller is OFF or while the motor is in OFF status (MOTOR OFF).

Move the shaft down to its lower limit before the replacement procedure following the removal steps.

### Joint #3 motor Removal

- (1) Turn ON the Controller.
- (2) Push down the shaft to its lower limit while pressing the brake release switch. Be sure to keep enough space and prevent the end effector hitting any peripheral equipment.

LS3: The brake release switch affects only Joint #3. When the brake release switch is pressed, the Joint #3 brake is released.

Be careful of the shaft while the brake release switch is being pressed because the shaft may be lowered by the weight of an end effector.

LS6: The brake release switch is applied to both Joints #3 and Joint #4.

When the brake release switch is pressed, the respective brakes of the Joint #3 and Joint #4 are released simultaneously.

Be careful of the shaft falling and rotating while the brake release switch is being pressed because the shaft may be lowered by the weight of an end effector.

- (3) Turn OFF the Controller.
- (4) Remove the Arm Top Cover.

For details, refer to *Maintenance: 3.1 Arm Top Cover*.

- (5) Remove the control board.

For details, refer to *Maintenance: 11.3 Replacing Gyro Board*.

- (6) Cut off the wire tie binding the cables.

At this point, do not cut off a wire tie (in the duct fittings outlet) that binds the cables to the User Plate.

- (7) Remove the User Plate.

For details, refer to *Maintenance: 3.5 User Plate*.

- (8) Disconnect the following connectors.

Connectors X231, X31, X35 (Hold the claw to remove.)

- (9) Loosen the bolts for the Joint #3 motor unit.

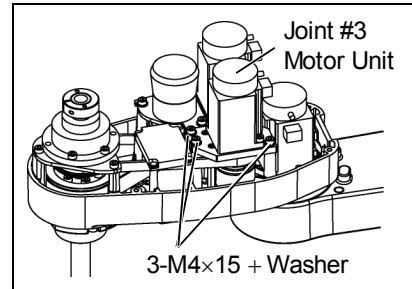

- (10) Remove the Joint #3 motor from the Joint #3 motor unit.

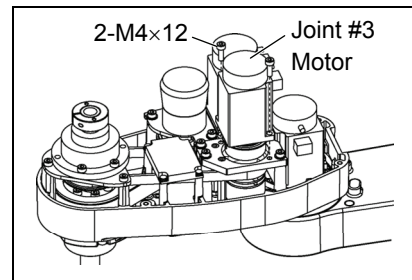

- (11) Loosen the screws of the pulley and brake hub and remove them from the Joint #3 motor.

There is a brass bushing in one of the set screw holes. Be sure to keep the bushing.

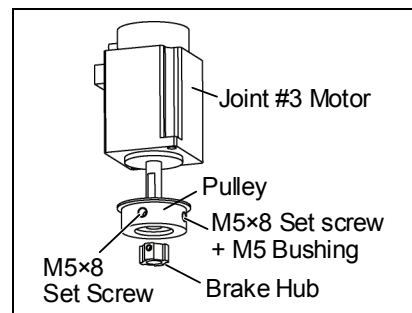

Joint #3 motor  
Installation

- (1) Mount the pulley and brake hub to the Joint #3 motor.

Insert the brake hub and secure it when it touches the motor shaft end face.

Secure the pulley when the pulley end face touches the brake hub.

Tighten one of the set screws vertically on the flat face of the motor shaft.

Insert a bushing into the other set screw hole to prevent damage to the motor shaft.

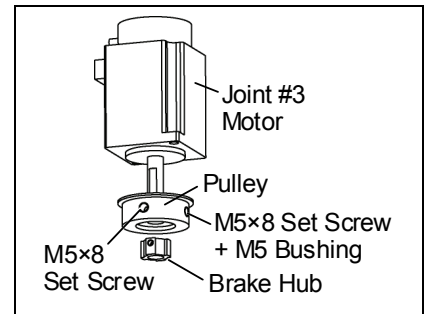

- (2) Mount the Joint #3 motor on the Z plate.

Pass the pulley through the Z belt and fit the brake disk to the hub.

Secure the motor cables facing to back of the Arm.

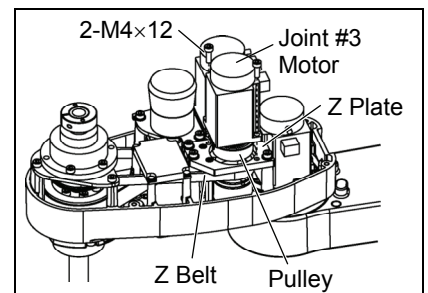

- (3) Loosely secure the Joint #3 motor unit to Arm #2.



Check that the motor unit can be moved by hand, and it will not tilt when pulled.

If the unit is secured too loose or too tight, the belt will not have the proper tension.

- (4) Apply the proper tension to the Z belt, and secure the Joint #3 motor unit.

Pass a suitable cord or string around the Joint #3 motor unit near its mounting plate. Then, pull the cord using a force gauge or similar tool to apply the specified tension shown in the figure on the right.

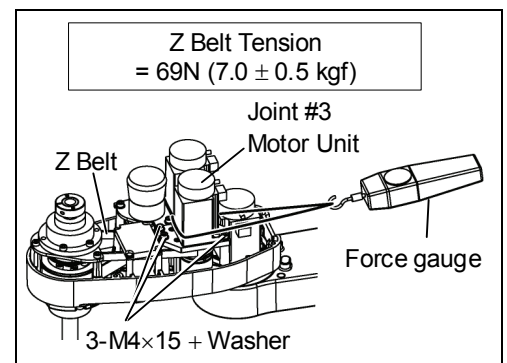

- (5) Mount the control board.

For details, refer to *Maintenance: 11.3 Replacing the Gyro Board*.

- (6) Connect the connectors: X231, X241, X31, X35, X41.

- (7) Mount the User Plate.

For details, refer to *Maintenance: 3.5 User Plate*.

- (8) Bind the cables with a wire tie in their original positions as before removed in the removal step (6).

Do not allow unnecessary strain on the cables.

- (9) Install the Arm Top Cover.

For details, refer to *Maintenance: 3.1 Arm Top Cover*.

- (10) Execute the calibration of Joints #3, #4.

For details, refer to *Maintenance: 13. Calibration*.

## 7.2 Replacing the Timing Belt

	Name	Quantity	Note
Maintenance parts	Z belt	(Width: 9 mm)	LS3-401*: R13B030233
		(Width: 10 mm)	LS6-602*: R13B030236
Tools	Hexagonal wrench (width across flats: 2.5 mm)	1	For M3 screw
	Hexagonal wrench (width across flats: 3 mm)	1	For M4 screw
	Torque wrench	1	
	Nippers	1	For cutting wire tie
	Force gauge	1	Belt tension 69 N (7.0 ± 0.5 kgf)
	Suitable cord (Length about 800 mm)	1	For belt tension
Material	Wire tie	-	



**LS3:** A brake is mounted on the Joint #3 motor to prevent the shaft from lowering down due to the weight of the end effector while the power to the Controller is OFF or while the motor is in OFF status (MOTOR OFF).

**LS6:** A brake is mounted on the motor of Joints #3 and #4 to prevent the shaft from moving down due to the weight of the end effector while the power to the Controller is OFF or while the motor is in OFF status (MOTOR OFF).

Move the shaft down to its lower limit before the replacement procedure following the removal steps.

### Z belt Removal

- (1) Turn ON the Controller.
- (2) Push down the shaft to its lower limit while pressing the brake release switch. Be sure to keep enough space and prevent the end effector hitting any peripheral equipment.

**LS3:** The brake release switch affects only Joint #3. When the brake release switch is pressed, the Joint #3 brake is released.

Be careful of the shaft while the brake release switch is being pressed because the shaft may be lowered by the weight of an end effector.

**LS6:** The brake release switch is applied to both Joints #3 and Joint #4.

When the brake release switch is pressed, the respective brakes of the Joint #3 and Joint #4 are released simultaneously.

Be careful of the shaft falling and rotating while the brake release switch is being pressed because the shaft may be lowered by the weight of an end effector.

- (3) Turn OFF the Controller.
- (4) Remove the Arm Top Cover.

For details, refer to *Maintenance: 3.1 Arm Top Cover*.

- (5) Remove the Gyro board.

For details, refer to *Maintenance: 11.3 Replacing the Control Board*.

- (6) Remove one screw that mounts the special power supply on the User Plate.

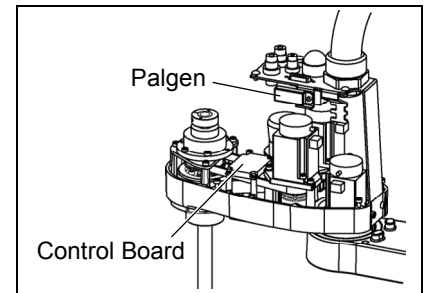

- (7) Cut off the wire tie binding the cables.

Cut off the wire tie binding the Joint #3 brake cable to the Arm #2 column.

At this point, do not cut off a wire tie (in the duct fittings outlet) that binds the cables to the User Plate.

- (8) Disconnect the following connectors.

Connectors X31, X32, X231 (Hold the claw to remove.)

- (9) Remove the User Plate.

For details, refer to *Maintenance: 3.5 User Plate*.

- (10) Remove the screws for the Joint #3 motor unit and pull out the Joint #3 motor unit.

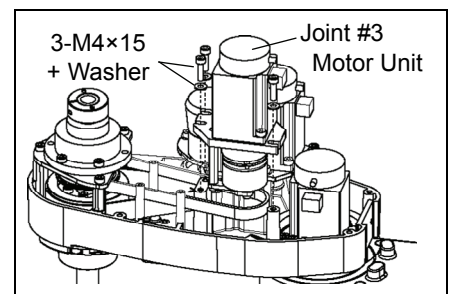

- (11) Remove the screws for the spline plate.

Holding the spline plate upward, pull out the Z belt.

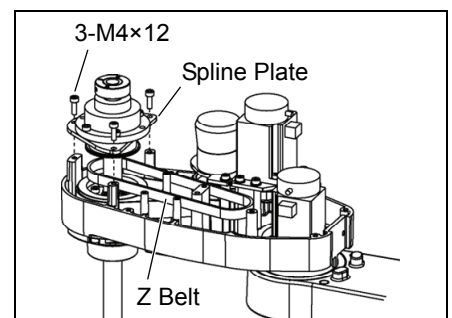

Z belt  
Installation

- (1) Pass a new Z belt through the shaft.
- (2) Lower the spline plate with the Z belt placed around the spline plate pulley.

Secure the spline plate with 3 screws.

Loosely secure the spline plate on the Arm #2 and move the shaft up and down several times before firmly secure the spline plate.

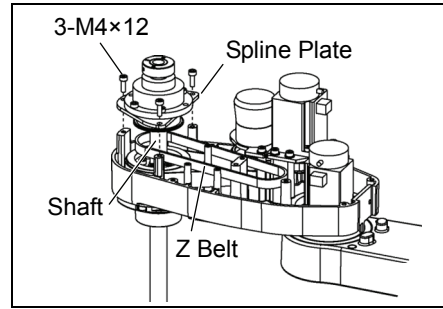

- (3) Mount the Joint #3 motor unit back in the arm.
- (4) Pass the brake cable and special power supply through the Z belt.

Place the Z belt around the Z1 pulley and Z2 pulley, with the gear grooves of the belt fitting into grooves of the pulleys completely.

- (5) Loosely secure the Joint #3 motor unit to the Arm #2.

Secure the ground wire with a mounting screw.

At this point, make sure that the Joint #3 motor unit can be moved by hand, and it will not tilt when pulled. If the unit is secured too loose or too tight, the belt will not have the proper tension.

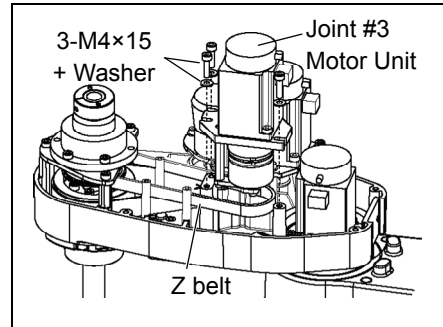

- (6) Apply the proper tension to the Z belt, and then secure the Joint #3 motor unit.

Pass a suitable cord or string around the Joint #3 motor unit near its mounting plate. Then, pull the cord using a force gauge or similar tool to apply the specified tension shown in the figure on the right.

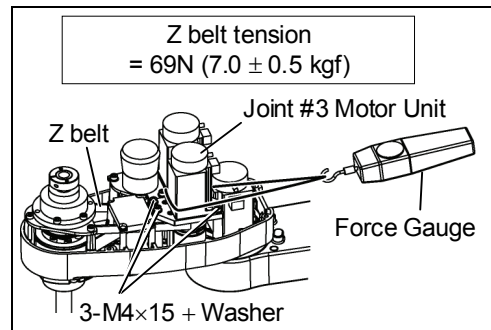

- (7) Mount the control board.  
For details, refer to *Maintenance: 11.3 Replacing the Control Board.*
- (8) Connect the connectors X231, X241, X31, X35, X41.
- (9) Mount the User Plate.  
For details, refer to *Maintenance: 3.5 User Plate.*
- (10) Bind the cables with a wire tie in their original positions as before removed in the removal step (7). Do not allow unnecessary strain on the cables.
- (11) Install the Arm Top Cover.  
For details, refer to *Maintenance: 3.1 Arm Top Cover.*
- (12) Execute the calibration of Joint #3.  
For details, refer to *Maintenance: 13. Calibration.*

## 7.3 Replacing the Brake

	Name	Quantity	Note
Maintenance parts	Solenoid brake	1	R13B030501
Tools	Hexagonal wrench (width across flats: 1.5 mm)	1	For M3 set screw
	Hexagonal wrench (width across flats: 2.5 mm)	1	For M3 screw
	Hexagonal wrench (width across flats: 3 mm)	1	For M4 screw
	Hexagonal wrench (width across flats: 4 mm)	1	For M5 screw
	Torque wrench	1	
	Nippers	1	For cutting wire tie
	Force gauge	1	Belt tension 69 N (7.0 ± 0.5 kgf)
	Suitable cord (Length about 800 mm)	1	For belt tension
Material	Wire tie	-	



LS3: A brake is mounted on the Joint #3 motor to prevent the shaft from lowering down due to the weight of the end effector while the power to the Controller is OFF or while the motor is in OFF status (MOTOR OFF).

LS6: A brake is mounted on the motor of Joints #3 and #4 to prevent the shaft from moving down due to the weight of the end effector while the power to the Controller is OFF or while the motor is in OFF status (MOTOR OFF).

Move the shaft down to its lower limit before the replacement procedure following the removal steps.

### Joint #3 brake Removal

- (1) Turn ON the Controller.
- (2) Push down the shaft to its lower limit while pressing the brake release switch. Be sure to keep enough space and prevent the end effector hitting any peripheral equipment.

LS3: The brake release switch affects only Joint #3. When the brake release switch is pressed, the Joint #3 brake is released.

Be careful of the shaft while the brake release switch is being pressed because the shaft may be lowered by the weight of an end effector.

LS6: The brake release switch is applied to both Joints #3 and Joint #4.

When the brake release switch is pressed, the respective brakes of the Joint #3 and Joint #4 are released simultaneously.

Be careful of the shaft falling and rotating while the brake release switch is being pressed because the shaft may be lowered by the weight of an end effector.

- (3) Turn OFF the Controller.
- (4) Remove the Arm Top Cover.

For details, refer to *Maintenance: 3.1 Arm Top Cover*.

- (5) Remove the Joint #3 motor unit.  
For details, refer to *Maintenance: 7.2 Replacing the Timing Belt*.

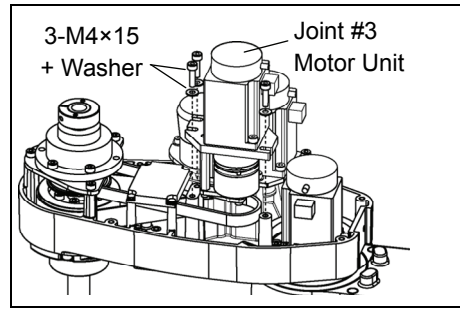

- (6) Remove the Joint #3 motor from the Joint #3 motor unit.

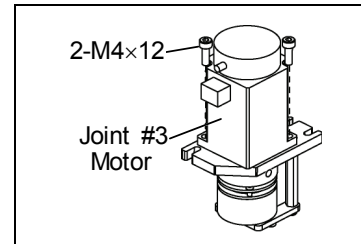

- (7) Remove the brake from the brake plate.

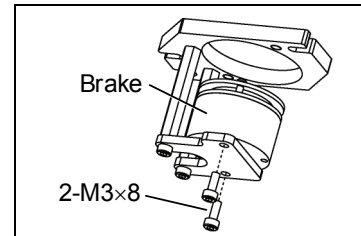

- (8) Loosen the screws of pulley and brake hub and remove them from the Joint #3 motor.  
There is a brass bushing in one of the set screw holes. Be sure to keep the bushing.

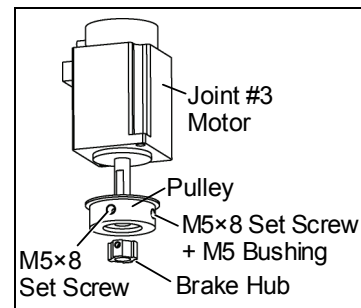



Joint #3 brake Installation

- (1) Mount the brake to the brake plate.

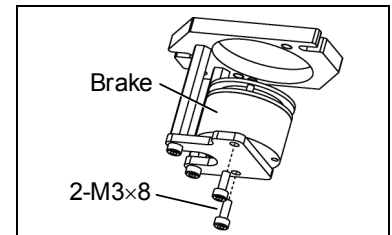

- (2) Mount the pulley and brake hub to the Joint #3 motor.

Insert the brake hub and secure it when it touches the motor shaft end face.

Secure the pulley when the pulley end face touches the brake hub.

Tighten one of the set screws vertically on the flat face of the motor shaft.

Insert a bushing into the other set screw hole to prevent damage to the motor shaft.

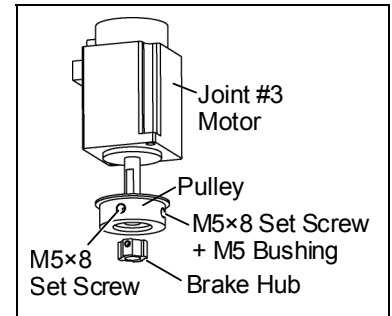

- (3) Mount the Joint #3 motor unit to the Z plate.

Align the position of the disk on the brake and the hub.

When the brake disk is not aligned, manually adjust the position after connecting the connector X32 and pressing the brake release switch to release the brake.

The motor cable must face the other side of the brake plate support columns.

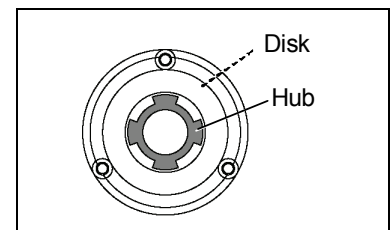

- (4) Mount the Joint #3 motor unit back in the Arm #2.

For details, refer to the section 7.2 *Replacing the Timing Belt*.

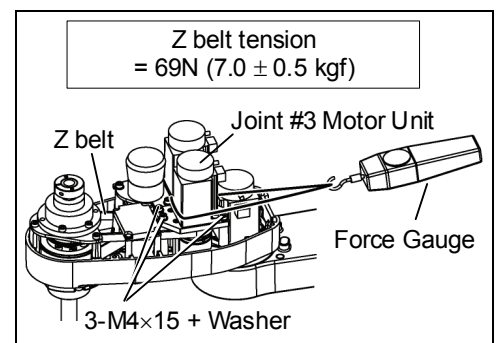

- (5) Mount the Arm Top Cover.

For details, refer to *Maintenance: 3.1 Arm Top Cover*.

- (6) Execute the calibration of Joint #3.

For details, refer to *Maintenance: 13. Calibration*.

## 8. Arm #4

 WARNING	<ul style="list-style-type: none"> <li>■ Do not insert or pull out the motor connectors while the power to the robot system is turned ON. Inserting or pulling out the motor connectors with the power ON is extremely hazardous and may result in serious bodily injury as the Manipulator may move abnormally, and also may result in electric shock and/or malfunction of the robot system.</li> <li>■ To shut off power to the robot system, pull out the power plug from the power source. Be sure to connect the AC power cable to a power receptacle. DO NOT connect it directly to a factory power source.</li> <li>■ Before performing any replacement, turn OFF the Controller and related equipment, and then pull out the power plug from the power source. Performing any replacement with the power ON is extremely hazardous and may result in electric shock and/or malfunction of the robot system.</li> </ul>
--	---

 CAUTION	<ul style="list-style-type: none"> <li>■ Be careful not to apply excessive shock to the motor shaft when replacing the motors. The shock may shorten the life cycle of the motors and encoder and/or damage them.</li> <li>■ Never disassemble the motor and encoder. A disassembled motor and encoder will cause a positional gap and cannot be used again.</li> </ul>
--	---

After parts have been replaced (motors, reduction gear units, brakes, timing belts, ball screw spline unit, etc.), the Manipulator cannot operate properly because a mismatch exists between the origin stored in each motor and its corresponding origin stored in the Controller.

After replacing the parts, it is necessary to match these origins.

The process of aligning the two origins is called “Calibration”.

Refer to *Maintenance: 13. Calibration* to execute the calibration.

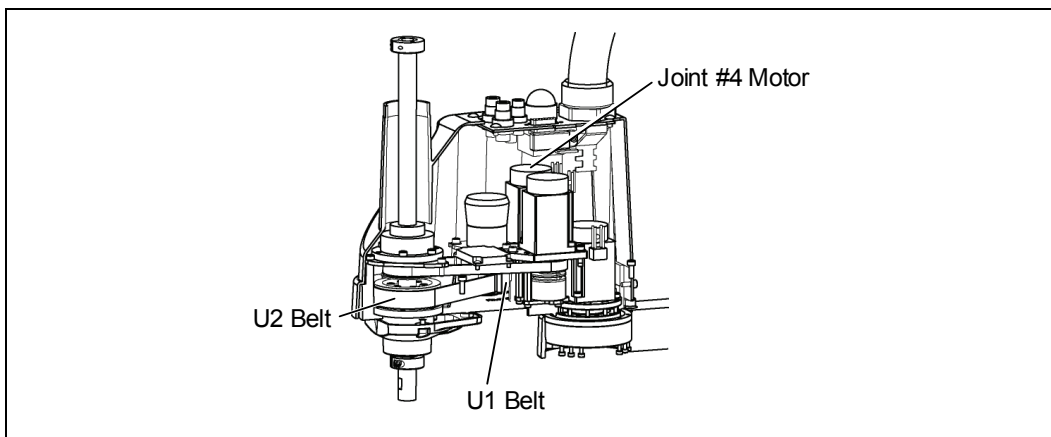

## 8.1 Replacing Joint #4 Motor

	Name	Quantity	Note
Maintenance parts	AC Servo Motor (100 W)	1	R13B000101
Tools	Hexagonal wrench (width across flats: 2 mm)	1	For M4 set screw
	Hexagonal wrench (width across flats: 3 mm)	1	For M4 screw
	Torque wrench	1	
	Nippers	1	For cutting wire tie
	Force gauge	1	Belt tension 39 N (4.0 ± 0.5 kgf)
	Suitable cord (Length about 800 mm)	1	For belt tension



**NOTE** LS3: A brake is mounted on the Joint #3 motor to prevent the shaft from lowering down due to the weight of the end effector while the power to the Controller is OFF or while the motor is in OFF status (MOTOR OFF).

LS6: A brake is mounted on the motor of Joints #3 and #4 to prevent the shaft from moving down due to the weight of the end effector while the power to the Controller is OFF or while the motor is in OFF status (MOTOR OFF).

Move the shaft down to its lower limit before the replacement procedure following the removal steps.

### Joint #4 motor Removal

- (1) Turn ON the Controller.
- (2) Push down the shaft to its lower limit while pressing the brake release switch. Be sure to keep enough space and prevent the end effector hitting any peripheral equipment.

LS3: The brake release switch affects only Joint #3. When the brake release switch is pressed, the Joint #3 brake is released.

Be careful of the shaft while the brake release switch is being pressed because the shaft may be lowered by the weight of an end effector.

LS6: The brake release switch is applied to both Joints #3 and Joint #4.

When the brake release switch is pressed, the respective brakes of the Joint #3 and Joint #4 are released simultaneously.

Be careful of the shaft falling and rotating while the brake release switch is being pressed because the shaft may be lowered by the weight of an end effector.

- (3) Turn OFF the Controller.
- (4) Remove the Arm Top Cover.

For details, refer to *Maintenance: 3.1 Arm Top Cover*.

- (5) Cut off the wire tie binding the cables.

At this point, do not cut off a wire tie (in the duct fittings outlet) that binds the cables to the User Plate.

- (6) Disconnect the connectors X241, X41. (Hold the claw to remove.)
- (7) Remove the User Plate.

For details, refer to *Maintenance: 3.5 User Plate*.

- (8) Remove the Joint #4 motor unit from the Arm #2.

Remove the bolts securing the Joint #4 motor on the motor plate and pull out the motor.

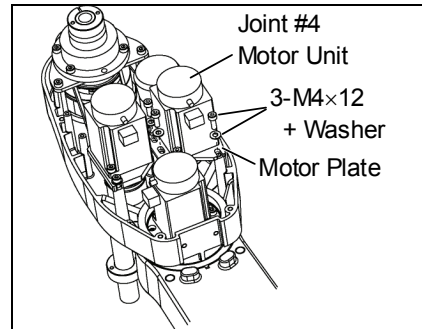

- (9) Remove the pulley from the Joint #4 motor.

There is a brass bushing in one of the set screw holes. Be sure to keep the bushing.

- (10) Remove the motor plate from the Joint #4 motor.

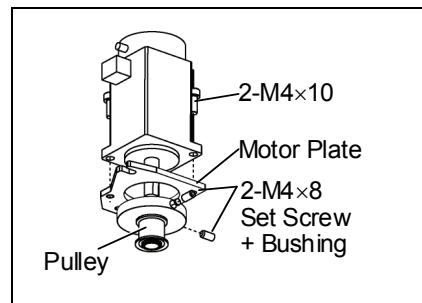

**Joint #4 motor Installation** (1) Mount the motor plate to the Joint #4 motor.  
At this point, the motor cables must be in the convex shape side of the plate.

- (2) Mount the pulley to the Joint #4 motor.  
Be sure to fit the end face of the pulley to the end face of the motor shaft.

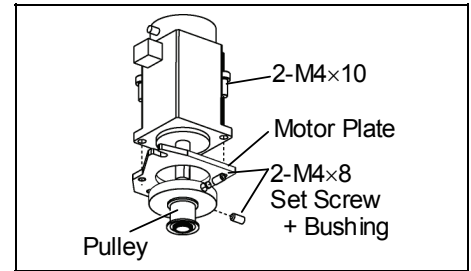

Tighten one of the set screws vertically on the flat face of the motor shaft.

Insert a bushing into the other set screw hole to prevent damage to the motor shaft.  
Then, tighten both set screws.

- (3) Place the pulley around the U1 belt and place the Joint #4 motor unit in the upper face of the Arm #2.

- (4) Loosely secure the Joint #4 motor unit to Arm #2.



NOTE Make sure the motor unit can be moved by hand, and it will not tilt when pulled. If the unit is secured too loose or too tight, the belt will not have the proper tension.

Make sure the gear grooves of the belt are fit into those of the pulleys completely.

- (5) Apply the proper tension to the U1 belt and secure the Joint #4 motor unit.

Pass a suitable cord or string around the Joint #4 motor unit near its mounting plate.

Then, pull the cord using a force gauge or similar tool to apply the specified tension shown in the figure.

- (6) Connect the connectors X241 and X41.

- (7) Mount the User Plate.

For details, refer to *Maintenance: 3.5 User Plate*.

- (8) Mount the control board.

For details, refer to *Maintenance: 11.3 Replacing the Gyro Board*.

- (9) Bind the cables with a wire tie in their original positions as before removed in removal step (5). Do not allow unnecessary strain on the cables.

- (10) Mount the Arm Top Cover.

For details, refer to *Maintenance: 3.1 Arm Top Cover*.

- (11) Execute the calibration of Joint #4.

For details on the calibration method, refer to *Maintenance: 13. Calibration*.

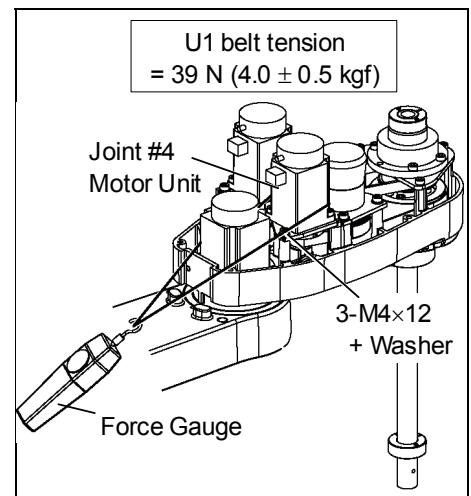
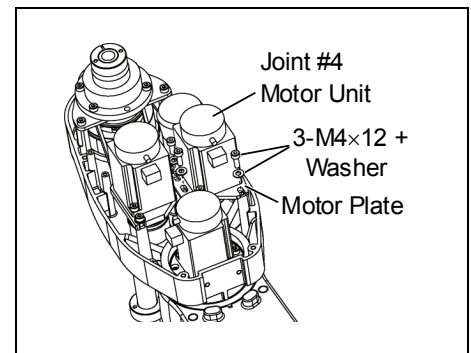

## 8.2 Replacing the Timing Belt

	Name		Quantity	Note
Maintenance parts	U1 belt	(Width 10 mm)	1	LS3-401*: R13B030234
				LS6-602*: R13B030237
	U2 belt	(Width 16 mm)	1	LS3-401*: R13B030235
		(Width 15 mm)		LS6-602*: R13B030238
Tools	Hexagonal wrench (width across flats: 3 mm)		1	For M4 screw
	Spanner (width across flats: 7 mm)		1	
	Torque wrench		1	
	Nippers		1	For cutting wire tie
	Force gauge		1	Belt tension 69N (7.0 ± 0.5 kgf) 39N (4.0 ± 0.5 kgf)
	Suitable cord (Length about 800 mm)		1	For belt tension

## NOTE



LS3: A brake is mounted on the Joint #3 motor to prevent the shaft from lowering down due to the weight of the end effector while the power to the Controller is OFF or while the motor is in OFF status (MOTOR OFF).

LS6: A brake is mounted on the motor of Joints #3 and #4 to prevent the shaft from moving down due to the weight of the end effector while the power to the Controller is OFF or while the motor is in OFF status (MOTOR OFF).

Move the shaft down to its lower limit before the replacement procedure following the removal steps.

### 8.2.1 U2 Belt

#### U2 belt Removal

- (1) Turn ON the Controller.
- (2) Push down the shaft to its lower limit while pressing the brake release switch. Be sure to keep enough space and prevent the end effector hitting any peripheral equipment.

LS3: The brake release switch affects only Joint #3. When the brake release switch is pressed, the Joint #3 brake is released.

Be careful of the shaft while the brake release switch is being pressed because the shaft may be lowered by the weight of an end effector.

LS6: The brake release switch is applied to both Joints #3 and Joint #4.

When the brake release switch is pressed, the respective brakes of the Joint #3 and Joint #4 are released simultaneously.

Be careful of the shaft falling and rotating while the brake release switch is being pressed because the shaft may be lowered by the weight of an end effector.

- (3) Turn OFF the Controller.
- (4) Remove the Arm Top Cover.

For details, refer to *Maintenance: 3.1 Arm Top Cover*.

- (5) Remove the control board.

For details, refer to *Maintenance: 11.3 Replacing the Control Board*.

- (6) Remove one screw that mounts the special power supply on the User Plate.

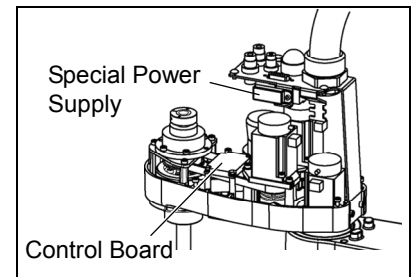

- (7) Cut off the wire tie binding the cables.

Cut off the wire tie binding the Joint #3 brake cable to the Arm #2 column.

At this point, do not cut off a wire tie (in the duct fittings outlet) that binds the cables to the User Plate.

- (8) Disconnect the following connectors.

Connectors X31, X32, X35, X41, X231, X241 (Hold the claw to remove.)

- (9) Remove the User Plate.

For details, refer to *Maintenance: 3.5 User Plate*.

- (10) Remove the screws securing the Joint #3 motor unit and pull out the motor unit.

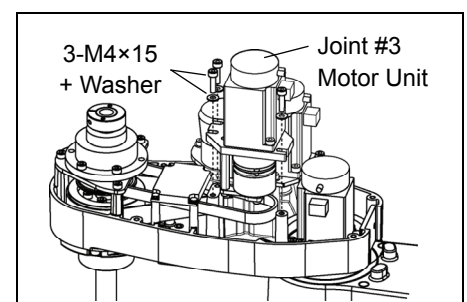

- (11) Remove the screws securing the Joint #4 motor unit and pull out the motor unit.

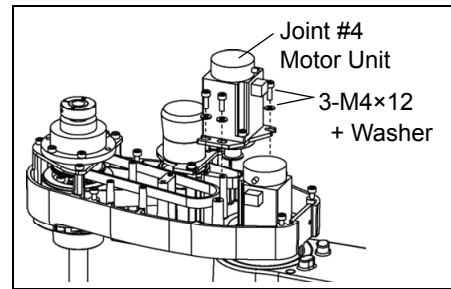

- (12) Remove the screws securing the Joint #4 intermediate shaft unit.

Pull out the Joint #4 intermediate shaft unit and U1 belt.

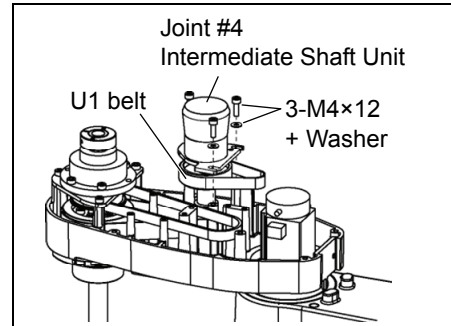

- (13) Remove the screws mounting the spline plate.

Hold up the spline plate and pull out the Z belt and U2 belt.

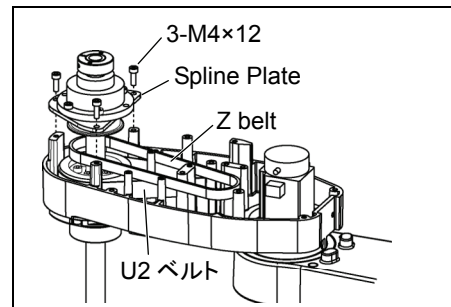



U2 belt  
Installation

- (1) Hold up the spline plate and set the U2 belt around the U3 pulley.

Make sure the gear grooves of the belt are fit into those of the pulleys completely.

- (2) Hold up the spline plate and set the Z belt around the Z2 pulley.

Make sure the gear grooves of the belt are fit into those of the pulleys completely.

- (3) Loosely secure the spline plate on the Arm #2 and move the shaft up and down several times before firmly secure the spline plate.

- (4) Keeping the U1 belt on the large pulley of the Joint #4 intermediate shaft unit, set the U2 belt in the Arm #2 on the small pulley and put them on the Arm #2 upper surface.

Make sure the gear grooves of the belts are fit into those of the pulleys completely.

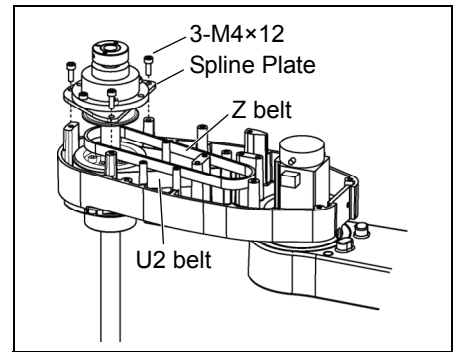

- (5) Loosely secure the Joint #4 intermediate shaft unit.

Make sure the unit can be moved by hand, and it will not tilt when pulled. If the unit is secured too loose or too tight, the belt will not have the proper tension.

- (6) Apply the proper tension to the U2 belt, and then secure the Joint #4 intermediate shaft unit.

Pass a suitable cord or string around the Joint #4 intermediate shaft unit near its mounting plate.

Then, pull the cord using a force gauge or similar tool to apply the specified tension shown in the figure on the right.

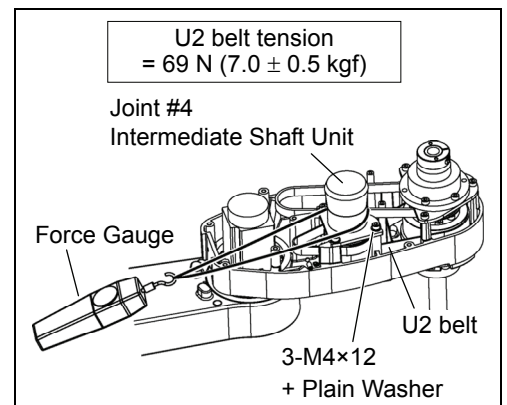

- (7) Mount the Joint #4 motor unit on the Arm #2 with the U1 belt around the pulley.

- (8) Loosely secure the Joint #4 motor unit to the Arm #2.

Make sure the motor unit can be moved by hand, and it will not tilt when pulled. If the unit is secured too loose or too tight, the belt will not have the proper tension.

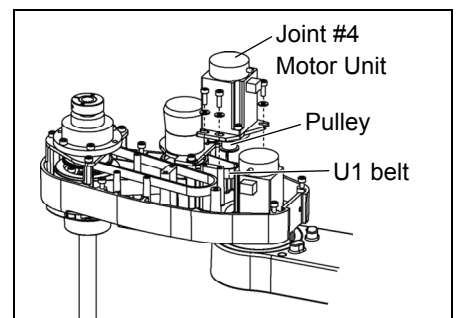

- (9) Apply the proper tension to the U1 belt and secure the Joint #4 motor unit.

Pass a suitable cord or string around the Joint #4 motor unit near its mounting plate.

Then, pull the cord using a force gauge or similar tool to apply the specified tension shown in the figure on the right.

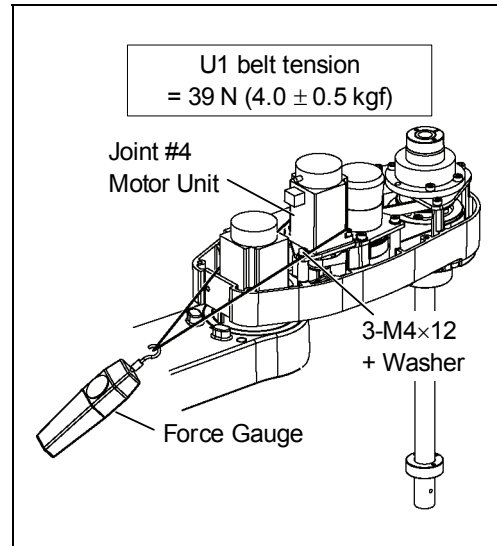

- (10) Put the Joint #3 motor unit back in the arm.

- (11) Pass the brake cable and special power supply through the Z belt.

Set the Z belt around the Z1 pulley and Z2 pulley, with the gear grooves of the belt fitting into grooves of the pulleys completely.

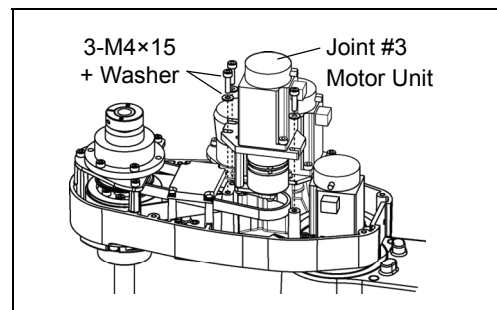

- (12) Loosely secure the Joint #3 motor unit to Arm #2.

Secure the ground wire with a mounting screw.

Make sure the motor unit can be moved by hand, and it will not tilt when pulled. If the unit is secured too loose or too tight, the belt will not have the proper tension.

- (13) Apply the proper tension to the Z belt and secure the Joint #3 motor unit.

Pass a suitable cord or string around the Joint #3 motor unit near its mounting plate.

Then, pull the cord using a force gauge or similar tool to apply the specified tension shown in the figure on the right.

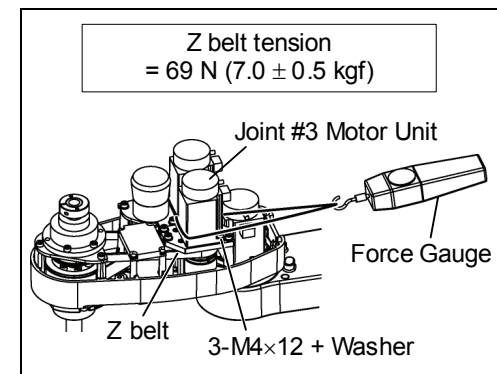

- (14) Remove the control board.

For details, refer to *Maintenance: 11.3 Replacing the Control Board*.

- (15) Connect the following connectors.

Connector X31, X32, X35, X41, X231, X241

- (16) Mount the User Plate.

For details, refer to *Maintenance: 3.5 User Plate*.

- (17) Bind the cables with a wire tie in their original positions as before removed in the removal step (7).

Do not allow unnecessary strain on the cables.

- (18) Remove the Arm Top Cover.

For details, refer to *Maintenance: 3.1 Arm Top Cover*.

- (19) Execute the calibration for Joint #3.

For details on the calibration method, refer to *Maintenance: 13. Calibration*.

### 8.2.2 U1 Belt

#### U1 belt Removal

- (1) Remove the Joint #4 motor.  
Follow the removal steps in *Maintenance: 8.2.1 U2 Belt*.

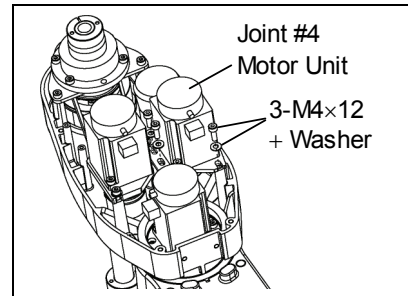

- (2) Remove the Joint #4 intermediate shaft unit.  
Follow the removal steps in *Maintenance: 8.2.1 U2 Belt*.

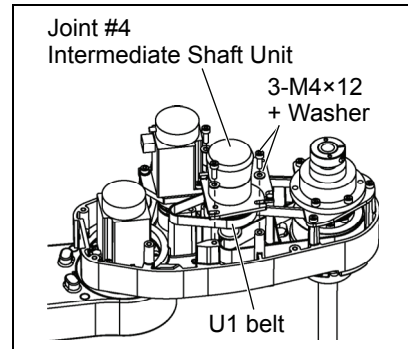

- (3) Remove the U1 belt.

U1 belt  
Installation

- (1) Keeping the U1 belt on the large pulley of the Joint #4 intermediate shaft unit, set the U2 belt in the Arm #2 on the small pulley and put them on the Arm #2 upper surface.



NOTE Make sure the gear grooves of the belts are fit into those of the pulleys completely.

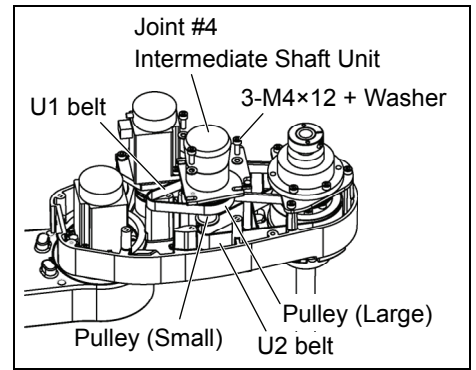

- (2) Loosely secure the Joint #4 intermediate shaft unit.

Make sure the motor unit can be moved by hand, and it will not tilt when pulled.  
If the unit is secured too loose or too tight, the belt will not have the proper tension.

- (3) Apply the proper tension to the U2 belt, and then secure the Joint #4 intermediate shaft unit.

Pass a suitable cord or string around the Joint #4 intermediate shaft unit near its mounting plate.

Then, pull the cord using a force gauge or similar tool to apply the specified tension shown in the figure on the right.

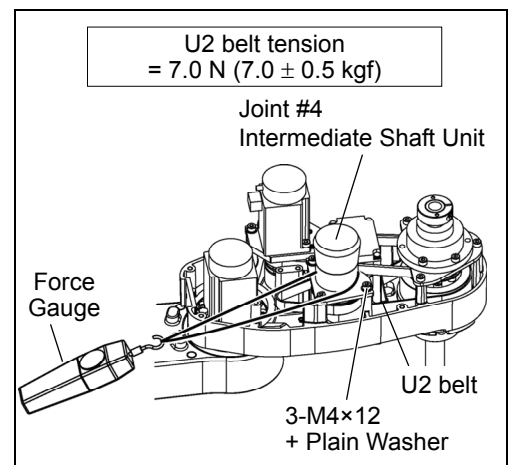

- (4) Loosely secure the Joint #4 motor unit to Arm #2.

Make sure the motor unit can be moved by hand, and it will not tilt when pulled.  
If the unit is secured too loose or too tight, the belt will not have the proper tension.

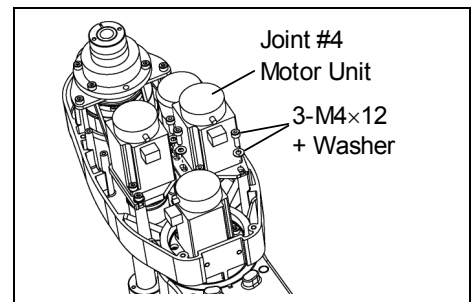

- (5) Apply the proper tension to the U1 belt, and then secure the Joint #4 intermediate shaft unit.

Pass a suitable cord or string around the Joint #4 motor unit near its mounting plate.

Then, pull the cord using a force gauge or similar tool to apply the specified tension shown in the figure on the right.

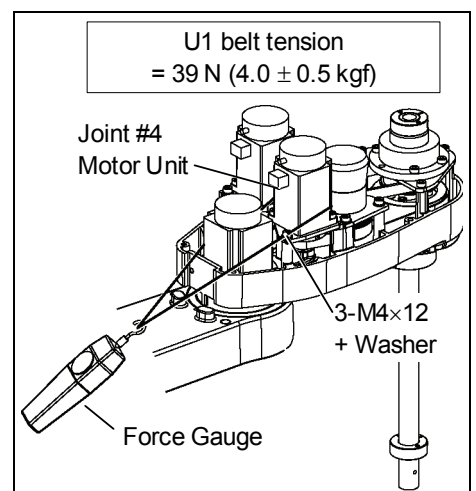

- (6) Connect the connector X241, X41.
- (7) Bind the cables with a wire tie in their original position as before removed in the removal step (5).
- (8) Remove the User Plate.  
For details, refer to *Maintenance: 3.5 User Plate*.
- (9) Install the Arm Top Cover.  
For details, refer to *Maintenance: 3.1 Arm Top Cover*.
- (10) Execute the calibration of Joint #4.  
For details, refer to *Maintenance: 13. Calibration*.

### 8.3 Replacing the Brake (For LS6 series)

	Name	Quantity	Note
Maintenance parts	Solenoid brake	1	R13B030502
Tools	Hexagonal wrench (width across flats: 1.3 mm)	1	For M2.5 set screw
	Hexagonal wrench (width across flats: 2 mm)	1	For M2.5 screw
	Nippers	1	For cutting wire tie
Material	Wire tie	1	

A brake is mounted on the motor of Joints #3 and #4 of LS6 series to prevent the shaft from moving down due to the weight of the end effector while the power to the Controller is OFF or while the motor is in OFF status (MOTOR OFF).

Move the shaft down to its lower limit before the replacement procedure following the removal steps.

For LS6 series

(1) Turn ON the Controller.

Joint #4 brake  
Removal

(2) Push down the shaft to its lower limit while pressing the brake release switch. Be sure to keep enough space and prevent the end effector hitting any peripheral equipment.

The brake release switch is applied to both Joint #3 and #4. When the brake release switch is pressed, the respective brake for Joints #3 and #4 are released simultaneously.

Be careful of the shaft falling and rotating while the brake release switch is being pressed because the shaft may be lowered by the weight of an end effector.

(3) Turn OFF the Controller.

(4) Remove the Arm Top Cover.

For details, refer to *Maintenance: 3.1 Arm Top Cover*.

(5) Disconnect the connector X42.

(6) Cut off the wire tie banding brake cables.

(7) Remove the rubber cap.

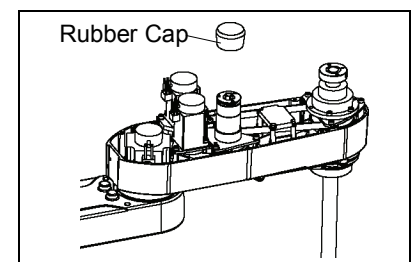

(8) Remove the brake hub.

(9) Remove the brake.

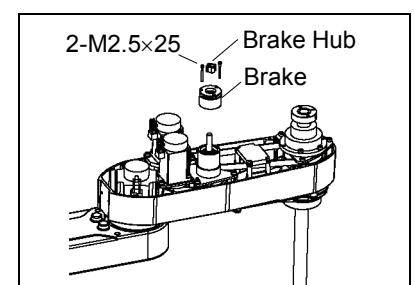

For LS6 series (1) Mount the brake to the Joint #4 intermediate shaft unit.

Joint #4 brake Installation (2) Mount the brake hub to the Joint #4 intermediate shaft unit.

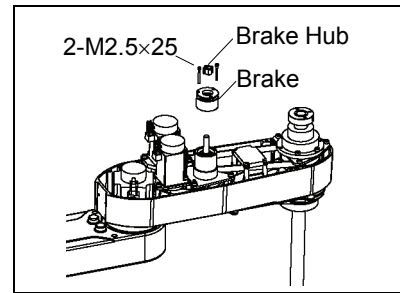

(3) Mount the rubber cap.

Insert 9 mm to the brake.

If the cap is inserted 10 mm or more, the rotation part touches the rubber cap and may result in malfunctions.

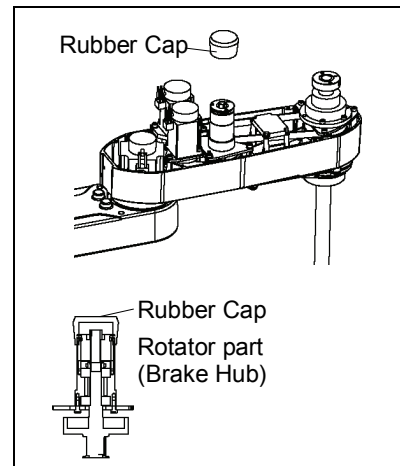

(4) Connect the connector X42.

(5) Re-bundle the cables in their original positions with a wire tie removed in step (6).

Do not allow unnecessary strain on the cables.

(6) Install the Arm Top Cover.

For details, refer to *Maintenance: 3.1 Arm Top Cover*.



# 9. Bellows

**NOTE**  A large amount of dust is emitted when replacing the bellows.  
Take the Manipulator to an outer room such as the room in front of the clean room's entrance, or take the necessary countermeasures to prevent dust emission before removing the bellows.

	Name	Quantity	Note
Maintenance parts	Bellows	1	LS3-401C: R13B030704 LS6-602C: R13B030708 Bellows are supplied in pairs.
Tools	Cross-point screwdriver	1	For clamp band removal

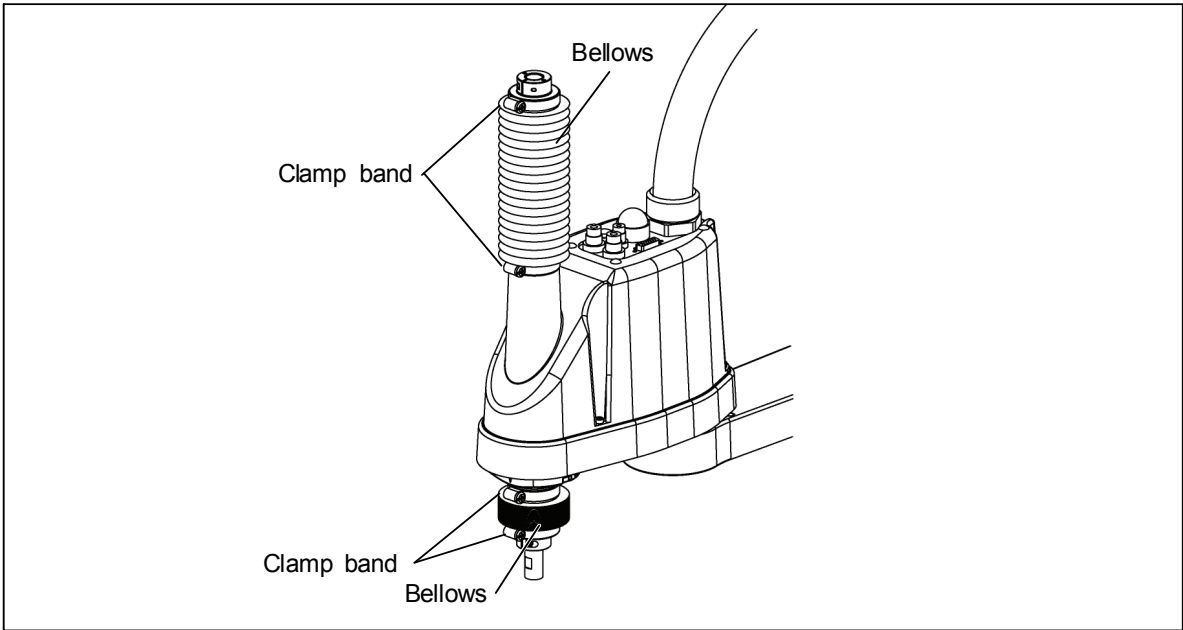

- Bellows Removal**
- (1) Remove the cables and tubes from the end effector.
  - (2) Remove the end effector.
  - (3) Turn ON the controller. Stop motor excitation. (MOTOR OFF)
  - (4) Loosen the two clamp bands on the bellows.
  - (5) Pull out the bellows and clamp bands from the shaft.

**Bellows Installation**

- (1) To attach the upper bellows, move the shaft to its lower limit.  
To attach the lower bellows, move the shaft to its upper limit.

To move the shaft up/down, press and hold the brake release switch.  
Be sure to keep enough space and prevent the end effector hitting any peripheral equipment.

**LS3:** The brake release switch affects only Joint #3. When the brake release switch is pressed, the Joint #3 brake is released.

Be careful of the shaft while the brake release switch is being pressed because the shaft may be lowered by the weight of an end effector.

**LS6:** The brake release switch is applied to both Joints #3 and Joint #4.

When the brake release switch is pressed, the respective brakes of the Joint #3 and Joint #4 are released simultaneously.

Be careful of the shaft falling and rotating while the brake release switch is being pressed because the shaft may be lowered by the weight of an end effector.

- (2) Pass the shaft through the bellows from the larger joint.

- (3) Secure the cover side of the bellows.

The bellows has two joints:  
The larger joint must be attached to the cover side.  
The smaller joint must be attached to the end face side of the shaft.  
Attach the mounting part of the bellows until the end touches the cylindrical part of the cover.

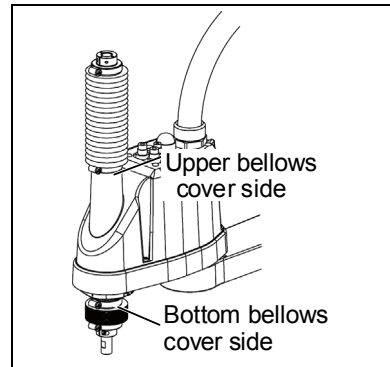

Then, secure them with clamp bands.

- (4) Secure the shaft edge side of the bellows.

Cover the bearing case (black) on the edge of the shaft with the bellows mounting part.

Then, secure them with clamp bands.

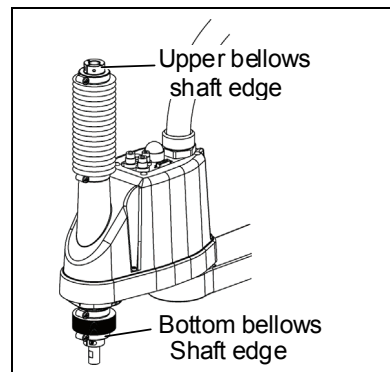

- (5) When completed the bellows installation, check that the bellows stretch smoothly without any excessive force by moving the shaft up/down by hand and rotating the Joint #4.
- (6) Turn OFF the Controller and peripheral equipments.
- (7) Attach the end effector.
- (8) Connect the cables and tubes to the end effector.

## 10. Ball Screw Spline Unit

 <b>WARNING</b>	<ul style="list-style-type: none"> <li>■ Do not insert or pull out the motor connectors while the power to the robot system is turned ON. Inserting or pulling out the motor connectors with the power ON is extremely hazardous and may result in serious bodily injury as the Manipulator may move abnormally, and also may result in electric shock and/or malfunction of the robot system.</li> <li>■ To shut off power to the robot system, pull out the power plug from the power source. Be sure to connect the AC power cable to a power receptacle. DO NOT connect it directly to a factory power source.</li> <li>■ Before performing any replacement procedure, turn OFF the Controller and related equipment, and then pull out the power plug from the power source. Performing any replacement procedure with the power ON is extremely hazardous and may result in electric shock and/or malfunction of the robot system.</li> </ul>
---	---

**NOTE**  After parts have been replaced (motors, reduction gear units, brakes, timing belts, ball screw spline unit, etc.), the Manipulator cannot operate properly because a mismatch exists between the origin stored in each motor and its corresponding origin stored in the Controller.

After replacing the parts, it is necessary to match these origins.

The process of aligning the two origins is called “Calibration”.

Refer to *Maintenance: 13. Calibration* to perform the calibration.

### 10.1 Greasing the Ball Screw Spline Unit

	Name	Quantity	Note
Maintenance parts	For Ball Screw Spline Unit (AFB grease)	Proper quantity	R13ZA00330200
Tools	Wiping cloth	1	For wiping grease (Spline shaft)
	Cross-point screwdriver	1	For clamp band removal Only for Cleanroom-model

**NOTE**  **LS3:** The brake release switch affects only Joint #3. When the brake release switch is pressed, the Joint #3 brake is released.

Be careful of the shaft while the brake release switch is being pressed because the shaft may be lowered by the weight of the end effector.

**LS6:** The brake release switch affects both Joints #3 and #4. When the brake release switch is pressed in emergency mode, the brake for both Joints #3 and #4 are released simultaneously.

Be careful of the shaft falling and rotating while the brake release switch is pressed because the shaft may be lowered by the weight of an end effector.

### 10.1.1 Standard-model (S type)

Cover the surrounding area such as the end effector and peripheral equipment in case the grease drips.

- (1) Turn ON the Controller. Stop motor excitation. (MOTOR OFF)
- (2) Move the arm to a position where Joint #3 can be moved in full stroke.
- (3) Move the shaft to its upper limit manually while pressing the brake release switch.
- (4) Turn OFF the Controller.
- (5) Wipe off the old grease from the upper part of the shaft, and then apply new grease to it.

When applying the new grease to the upper part of the shaft, directly fill the grooves on it by hand. Wipe off excess grease from the shaft.

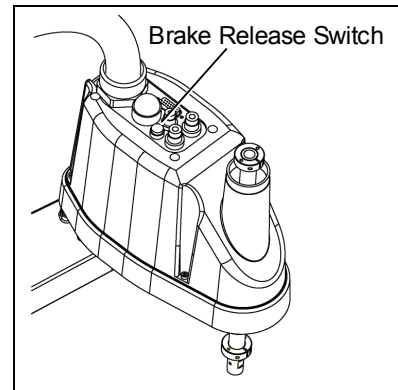

- (6) Turn ON the Controller.
- (7) Move the shaft to its lower limit by hand while pressing the brake release switch.
- (8) Wipe off the old grease from the lower part of the shaft, and then apply new grease to it.

When applying the new grease to the lower part of the shaft, directly fill the grooves on it by hand. Wipe off excess grease from the shaft.

- (9) Move the shaft up and down several times while pressing the brake release switch to smooth out the grease on the shaft. Wipe off excess grease from the shaft.

When wiping off the excess grease from the upper part of shaft, turn OFF the Controller and remove the Arm Top Cover.

For details, refer to *Maintenance: 3.1 Arm Top Cover*.

## 10.1.2 Cleanroom-model

Cover the surrounding area such as the end effector and peripheral equipment in case the grease drips.

Upper Part  
of the Shaft

- (1) Turn ON the Controller. Stop motor excitation. (MOTOR OFF)
- (2) Move the arm to a position where Joint #3 can be moved in full stroke.
- (3) Move the shaft to the lower limit manually while pressing the brake release switch.
- (4) Loosen the clamp band under the bellows, and then lift the bellows.
- (5) Move the shaft to the upper limit manually while pressing the brake release switch.

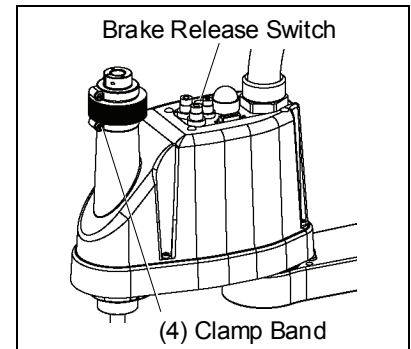

- (6) Wipe off the old grease from the upper part of the shaft, and then apply new grease.

Directly fill the grooves on the shaft inside the bellows with grease by hand.

Wipe off excess grease from the shaft.

Lower Part  
of the Shaft

- (7) Loosen the clamp band on the bellows, and then move the bellows downward.
- (8) Move the shaft to the lower limit manually while pressing the brake release switch.

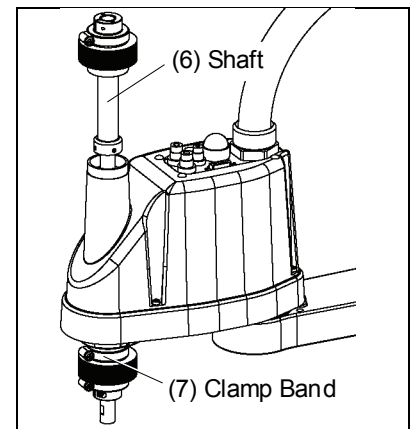

- (9) Wipe off the old grease from the lower part of the shaft, and then apply new grease.

Directly fill the grooves on the shaft inside the bellows with grease by hand.

Wipe off excess grease from the shaft.

- (10) Move the shaft up and down several times while pressing the brake release switch to smooth out the grease on the shaft. Wipe off excess grease from the shaft.

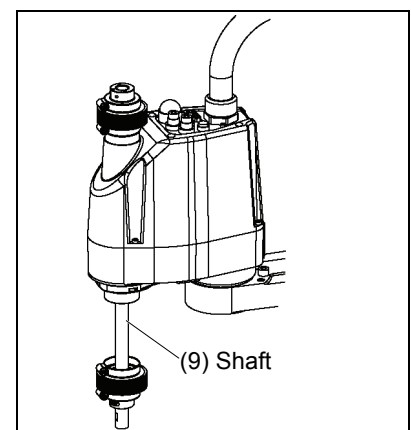

- (11) Secure the bellows.

To attach the upper bellows, move the shaft to its lower limit.

To attach the lower bellows, move the shaft to its upper limit.

To move the shaft up/down, press and hold the brake release switch.

Attach the mounting part of the bellows until it touches the cylindrical part of the cover.

Then, secure them with clamp bands.

## 10.2 Replacing the Ball Screw Spline Unit



LS3: A brake is mounted on the Joint #3 motor to prevent the shaft from lowering down due to the weight of the end effector while the power to the Controller is OFF or while the motor is in OFF status (MOTOR OFF).

LS6: A brake is mounted on the motor of Joints #3 and #4 to prevent the shaft from moving down due to the weight of the end effector while the power to the Controller is OFF or while the motor is in OFF status (MOTOR OFF).

Move the shaft down to its lower limit before the replacement procedure following the removal steps.

	Name	Quantity	Note
Maintenance parts	Ball Screw Spline Unit	1	Each manipulator model (Refer to <i>Maintenance: 14. Maintenance parts</i> )
	For Ball Screw Spline Unit (AFB grease)	Proper quantity	R13B010228
Tools	Hexagonal wrench (width across flats: 3 mm)	1	For M4 screw
	Torque wrench	1	
	Nippers	1	For cutting wire tie
	Cross-point screwdriver	1	Only for Cleanroom-model
	Force gauge	1	Belt tension 98 N (10 kgf) / 74 N (7.5 kgf)
	Suitable cord (Length about 1000 mm)	1	For belt tension
	Wiping cloth	1	For wiping grease (Spline shaft)
Material	Wire tie	-	

### Ball Screw Spline Unit Removal

- (1) Turn ON the Controller.
- (2) Push down the shaft to its lower limit while pressing the brake release switch. Be sure to keep enough space and prevent the end effector hitting any peripheral equipment.

LS3: The brake release switch affects only Joint #3. When the brake release switch is pressed, the Joint #3 brake is released.

Be careful of the shaft while the brake release switch is being pressed because the shaft may be lowered by the weight of an end effector.

LS6: The brake release switch is applied to both Joints #3 and Joint #4.

When the brake release switch is pressed, the respective brakes of the Joint #3 and Joint #4 are released simultaneously.

Be careful of the shaft falling and rotating while the brake release switch is being pressed because the shaft may be lowered by the weight of an end effector.

- (3) Turn OFF the Controller.
- (4) Detach the wires/tubes from the end effector, and remove the end effector.
- (5) This step is only for Cleanroom-model.

Remove the bellows. For details, refer to *Maintenance: 9. Bellows*.

- (6) Remove the Arm Top Cover and Arm Bottom Cover.

For details, refer to *Maintenance: 3. Covers*.

- (7) Remove the following.

Joint # motor unit // Joint #4 motor unit // Joint #4 intermediate pulley // U belt

Follow the U2 belt removal steps in *Maintenance: 8.2 Replacing the Timing Belt*.

- (8) Remove three screws mounting the spline plate.

- (9) Remove four screws mounting the spline nut.

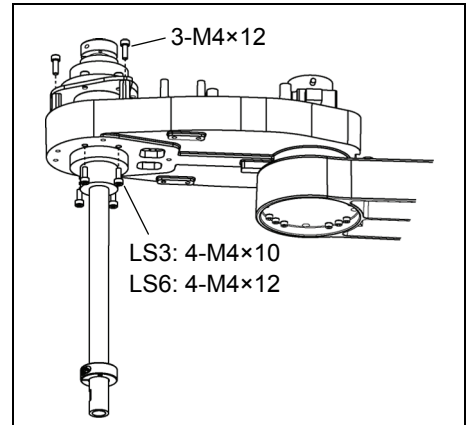

- (10) Pull out the following toward the Arm #2 upper side.

Ball screw spline unit / Z belt / U2 belt

Ball Screw  
Spline Unit  
Installation

- (1) Insert a new ball screw spline unit in the Arm #2.
- (2) Secure the spline nut from the bottom side of the Arm #2.

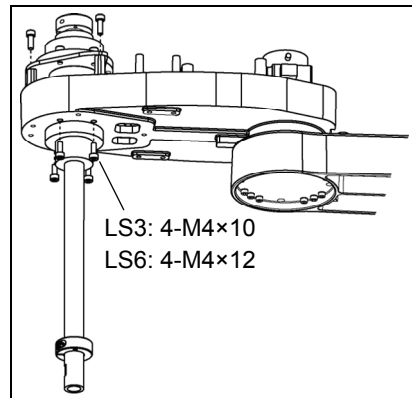

- (3) Mount the following.  
Joint #3 motor unit / Joint #4 motor unit / Joint #4 intermediate pulley /  
U1 belt / U2 belt / Z belt  
Follow the U2 belt installation steps in *Maintenance: 8.2 Replacing the Timing Belt*.
- (4) Mount the Arm Top Cover and Arm Bottom Cover.  
For details, refer to *Maintenance: 3. Covers*.
- (5) Grease the shaft.  
For details, refer to *Maintenance: 10.1 Greasing the Ball Screw Spline Unit*.
- (6) For the Cleanroom-model, mount the bellows.  
For details, refer to *Maintenance: 9. Bellows*.
- (7) Mount the end effector, cables, and tubes.
- (8) Perform the calibration of Joints #3, #4.  
For details, refer to *Maintenance: 13. Calibration*.



## 11. Lithium Battery and Boards

 <b>WARNING</b>	<ul style="list-style-type: none"> <li>■ Do not insert or pull out the motor connectors while the power to the robot system is turned ON. Inserting or pulling out the motor connectors with the power ON is extremely hazardous and may result in serious bodily injury as the Manipulator may move abnormally, and also may result in electric shock and/or malfunction of the robot system.</li> <li>■ To shut off power to the robot system, pull out the power plug from the power source. Be sure to connect the AC power cable to a power receptacle. DO NOT connect it directly to a factory power source.</li> <li>■ Before performing any replacement procedure, turn OFF the Controller and related equipment, and then pull out the power plug from the power source. Performing any replacement procedure with the power ON is extremely hazardous and may result in electric shock and/or malfunction of the robot system.</li> </ul>
---	---

 <b>WARNING</b>	<ul style="list-style-type: none"> <li>■ Use meticulous care when handling the lithium battery. Improper handling of the lithium battery as mentioned below is extremely hazardous, may result in heat generation, leakage, explosion, or inflammation, and may cause serious safety problems.            &lt;Improper Handling&gt;           <table style="margin-left: 20px; border: none;"> <tr> <td>- Battery Charge</td> <td>- Deformation by Pressure</td> </tr> <tr> <td>- Disassembly</td> <td>- Short-circuit (Polarity; Positive/Negative)</td> </tr> <tr> <td>- Incorrect Installation</td> <td>- Heating (85°C or more)</td> </tr> <tr> <td>- Exposing to Fire</td> <td>- Soldering the terminal of the lithium battery directly</td> </tr> <tr> <td>- Forced Discharge</td> <td></td> </tr> </table> </li> <li>■ When disposing of the battery, consult with the professional disposal services or comply with the local regulation.            Spent battery or not, make sure the battery terminal is insulated. If the terminal contacts with the other metals, it may short and result in heat generation, leakage, explosion, or inflammation.</li> </ul>	- Battery Charge	- Deformation by Pressure	- Disassembly	- Short-circuit (Polarity; Positive/Negative)	- Incorrect Installation	- Heating (85°C or more)	- Exposing to Fire	- Soldering the terminal of the lithium battery directly	- Forced Discharge	
- Battery Charge	- Deformation by Pressure										
- Disassembly	- Short-circuit (Polarity; Positive/Negative)										
- Incorrect Installation	- Heating (85°C or more)										
- Exposing to Fire	- Soldering the terminal of the lithium battery directly										
- Forced Discharge											

When the lithium battery power is low, an error will occur to warn the user about the low battery status when the Controller is turned ON (when software is started up).

When the error occurs, the position data in motors will be lost and all joints need to be completely calibrated again.

The life span of the lithium battery is 1.5 years. Even if the Manipulator is constantly connected to power, the lithium battery needs to be replaced every 1.5 years.

Make sure to use our specified lithium battery.

(Refer to *Maintenance: 14. Maintenance Parts List*.)

Be sure to set the correct polar when installing the battery.

Maintenance 11. Lithium Battery

---

	Name	Quantity	Note
Maintenance parts	Battery unit	1	R13B060007 Lithium battery for replacement (A set of 3 batteries)
	Resolver board	1	R13B040501
	Control board	1	R13B040502
Tools	Nippers	1	For cutting wire tie
	Hexagonal wrench (width across flats: 3 mm)	1	For M4 screw (For replacing battery board)
Material	Wire tie	2	For fixing battery unit (battery)

## 11.1 Replacing the Battery Unit (Lithium Battery)

### Battery unit (lithium battery) Removal

- (1) Turn OFF the controller.
- (2) Remove the Connector Plate.  
For details, refer to *Maintenance: 3.3 Connector Plate*.
- (3) Take out the battery plate from the Base.

Battery plate mounting screw: 1 - M3×5

Be careful not to disconnect the battery connector.



If you disconnect all the current batteries before connecting the new battery, the robot will lose the home position data and the calibration must be executed again. The battery units are exchanged according to the following procedures.

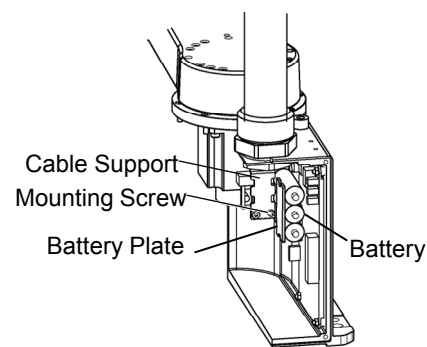

- (4) Cut off the wire tie binding the lithium batteries to the battery plate.
- (5) Bind new batteries to the battery plate with a new wire tie.
- (6) Mount the battery plate to the cable support.

Battery plate mounting screw: 1 - M3×5

- (7) Disconnect one connector of the old three batteries and connect a new one.
- (8) Disconnect the other old batteries connector and connect new ones.
- (9) Mount the Connector Plate.

For details, refer to *Maintenance: 3.3 Connector Plate*.

- (10) Turn ON the controller.
- (11) Check if the manipulator moves to points correctly in correct orientation.  
To do so, select some points already registered and move the manipulator to the points.
- (12) If the manipulator does not move to the points correctly, execute the calibration of all joints and axes.

For details, refer to *Maintenance: 13. Calibration*.

## 11.2 Replacing the Resolver Board

After battery board and parts have been replaced (motors, reduction gear units, brakes, timing belts, ball screw spline unit, etc.), the manipulator cannot operate properly because a mismatch exists between the origin stored in each motor and its corresponding origin stored in the controller.

After replacing the parts, it is necessary to match these origins.

The process of aligning the two origins is called “Calibration”.

Refer to *Maintenance: 13. Calibration* to execute the calibration.

### Resolver Board Removal

- (1) Turn OFF the controller.
- (2) Remove the Connector Plate.  
For details, refer to *Maintenance: 3.3 Connector Plate*.
- (3) Disconnect three batteries connectors and the M/C signal connector.

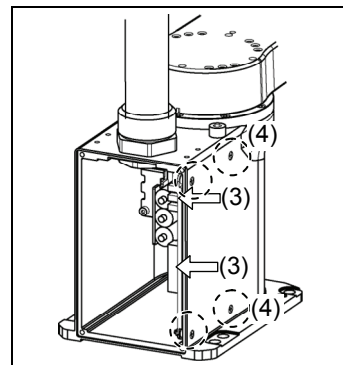

- (4) Remove the screws (flat head screw ×4) on the side face of the Base.

Slowly pull out the resolver board and heat-transfer sheet from the Base.

The signal connector is connected. Do not pull out forcibly.

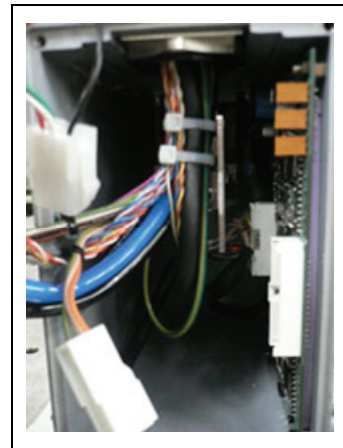

- (5) Disconnect the connectors X10 and X20 from the resolver board.

### Resolver Board Installation

- (1) Attach the heat-transfer sheet on the surface without connectors of a new resolver board.

Be sure to attach the sheet on the correct surface.



- (2) Connect the connectors X10 and X20 to the resolver board.
- (3) Put the surface with connectors of the resolver board toward the inside of the Base and slowly insert the resolver board into the Base.

Secure the board to the side face of the Base with the screws (flat head screws  $\times 4$ ).

Be careful not to remove the heat-transfer sheet while inserting the resolver board.

Secure the resolver board so that the Base side face and resolver board hold the heat-transfer sheet between them.



- (4) Connect the three batteries connectors and M/C signal connector.

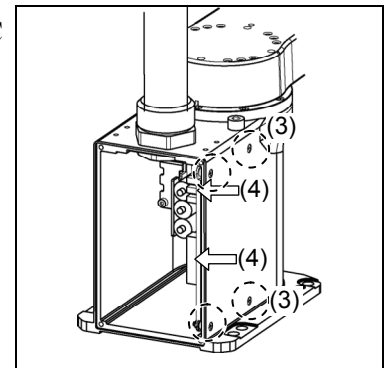

- (5) Mount the Connector Plate.

For details, refer to *Maintenance: 3.3 Connector Plate*.

- (6) Turn ON the Controller.

- (7) Execute the calibration of all joints and axes.

For details, refer to *Maintenance: 13. Calibration*.

## 11.3 Replacing the Control Board

- Control Board Removal
- (1) Turn OFF the controller.
  - (2) Remove the Arm Top Cover.  
For details, refer to *Maintenance: 3.1 Arm Top Cover*.
  - (3) Disconnect the connector X35.
  - (4) Remove the Control board.

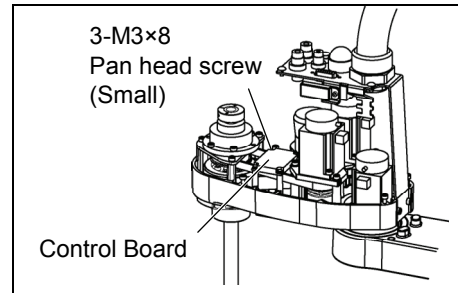

- Control Board Installation
- (1) Mount a new Control board.  
Be careful of the board direction.



- (2) Connect the connector X35.
- (3) Mount the Arm Top Cover.  
For details, refer to *Maintenance: 3.1 Arm Top Cover*.
- (4) Turn ON the controller.

## 12. LED Lamp



WARNING

- Do not insert or pull out the motor connectors while the power to the robot system is turned ON. Inserting or pulling out the motor connectors with the power ON is extremely hazardous and may result in serious bodily injury as the Manipulator may move abnormally, and also may result in electric shock and/or malfunction of the robot system.
- To shut off power to the robot system, pull out the power plug from the power source. Be sure to connect the AC power cable to a power receptacle. DO NOT connect it directly to a factory power source.
- Before performing any replacement procedure, turn OFF the Controller and related equipment, and then pull out the power plug from the power source. Performing any replacement with the power ON is extremely hazardous and may result in electric shock and/or malfunction of the robot system.

	Name	Quantity	Note
Maintenance parts	LED Lamp	1	R13A030000200
Tools	Cross-point screwdriver	1	For wire removal
	Nippers	1	
Material	Wire tie	1	

### LED Lamp Removal

- (1) Remove the Arm Top Cover.  
For details, refer to *Maintenance: 3.1 Arm Top Cover*.
- (2) Remove the User Plate.  
For details, refer to *Maintenance: 3.5 User Plate*.
- (3) Disconnect the X1 and X2 terminals from the LED.
- (4) Turn the lens counterclockwise to remove. Then, turn the lens holder counterclockwise to remove.
- (5) Remove the LED and ring from the User Plate.

### LED Lamp Installation

- (1) Connect the X1 and X2 terminals to the LED.  
Each terminal must be connected to the same terminal number on the LED.
- (2) Put the User Plate between the ring and lens holder, and then secure the LED to the cover.
- (3) Mount the lens.
- (4) Mount the User Plate.  
For details, refer to *Maintenance: 3.5 User Plate*.
- (5) Install the Arm Top Cover.  
For details, refer to *Maintenance: 3.1 Arm Top Cover*.

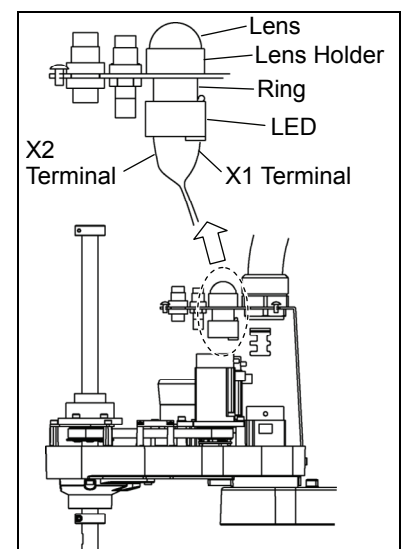

# 13. Calibration

## 13.1 About Calibration

After parts have been replaced (motors, reduction gear units, timing belts, etc.), the Manipulator cannot execute the positioning properly because a mismatch exists between the origin stored in each motor and its corresponding origin stored in the Controller.

After replacing the parts, it is necessary to match these origins.

The process of aligning the two origins is called “Calibration”. Note that calibration is not the same as teaching\*.

\*: “Teaching” means to teach the Controller coordinate points (including poses) anywhere in the operating area of the Manipulator.

 <b>WARNING</b>	<ul style="list-style-type: none"> <li>■ To ensure safety, a safeguard must be installed for the robot system. For details on the safeguard, refer to EPSON RC+ User’s Guide: <i>2.4 Installation and Design Precautions</i>.</li> <li>■ Before operating the robot system, make sure that no one is inside the safeguarded area. The robot system can be operated in the mode for teaching even when someone is inside the safeguarded area. The motion of the Manipulator is always in restricted (low speeds and low power) status to secure the safety of an operator. However, operating the robot system while someone is inside the safeguarded area is extremely hazardous and may result in serious safety problems in case that the Manipulator moves unexpectedly.</li> </ul>
---	--

### Command Input

Calibration procedures include the process to input commands. Select EPSON RC+ menu-[Tools]-[Command Window] to use the command window.

The information above is omitted in the calibration procedure.

### Jog Motion

The process to set the jog motion is included in the [Jog & Teach] page of the Robot Manager. Select EPSON RC+ menu-[Tools]-[Robot Manager] and select the [Jog & Teach] tab to use the [Jog & Teach] page.

The page above is indicated as [Jog & Teach] in the calibration procedure.



## 13.2 Calibration Procedure

EPSON RC+ has a wizard for calibration.

This section indicates the calibration using the calibration wizard of EPSON RC+.

The same calibration procedure is used for each joint.

The follow the steps below are calibration using Joint #1. Follow the steps below to calibrate other joints.

When coordinates for the Manipulator working point require calculation, it is important for Joint #2 to be calibrated accurately. Execute the procedure in “Calibration Using Right / Left Arm Orientations” to accurately calibrate Joint #2. For details, refer to *Maintenance: 13.3 Accurate Calibration of Joint #2*.

When calibrating Joint #4, you must calibrate Joint #3 and #4 at the same time. You cannot calibrate Joint #4 alone because of the structure of the Manipulator.



If Err9716 or 5016 (Power supply failure of the absolute encoder. Replace the battery. Check the robot internal wiring) occurs, apply the procedure of *13.4 Calibration Procedure without using Calibration Wizard - 3. Encoder Initialization* and then, start the calibration wizard.

The reference point (a point to check the accuracy) needs to be specified for calibration.

(1) Start the calibration wizard.

For EPSON RC+ 5.0:

- i. Select EPSON RC+ menu-[Setup]-[Controller] to display the [Controller] dialog.
- ii. Select [Robot]-[Calibration] to display [Robot Calibration].
- iii. Select the joint and click the <Calibrate...> button.

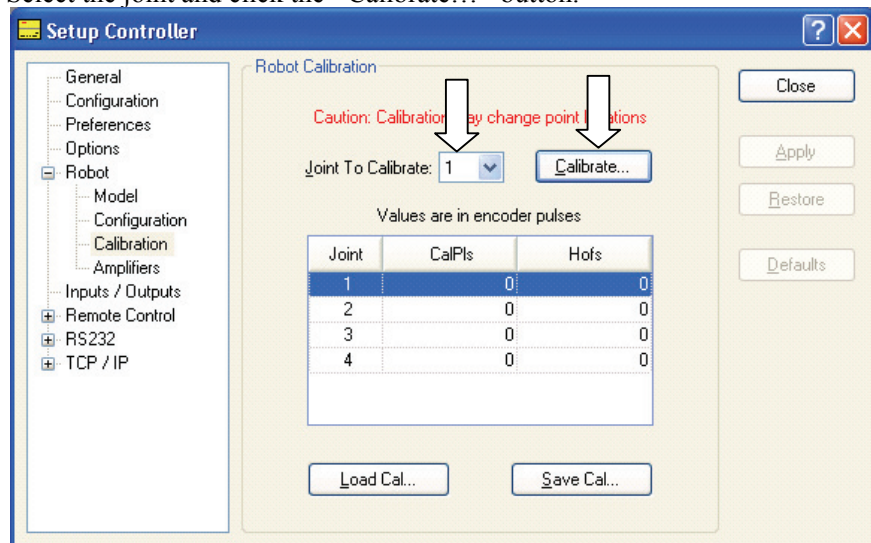

For EPSON RC+7.0:

- i. Select EPSON RC+ 7.0 menu - [Setup] to display the [System Configuration] dialog.
- ii. Select [Robots]-[Robot\*\*] to display [Calibration].
- iii. Select the joint and click the <Calibrate...> button.

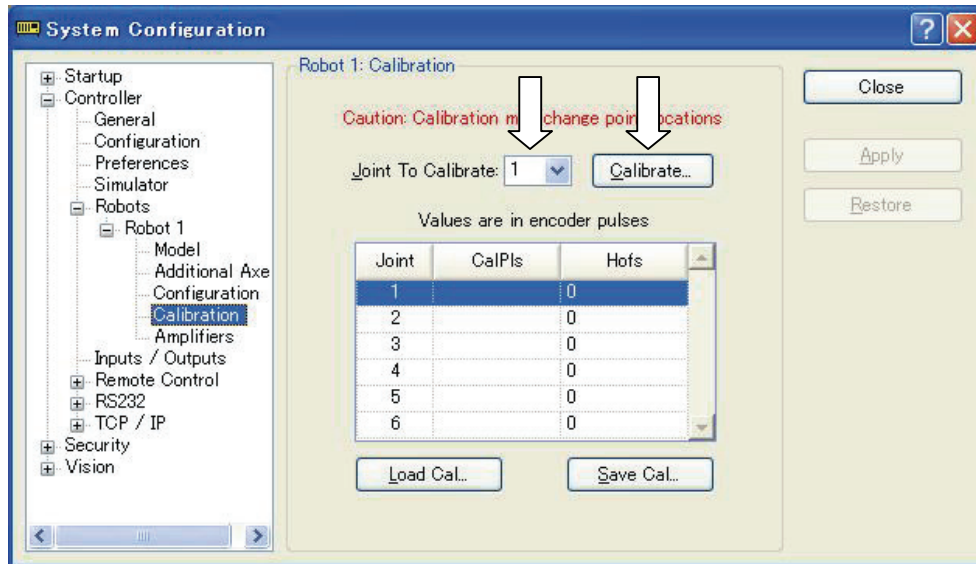

- (2) Confirm the warning message and click the <Yes> button.  
(Following steps use images of EPSON RC+ 5.0 dialogs.)

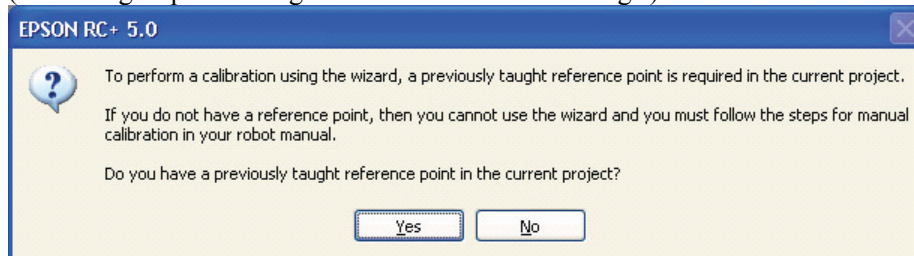

- (3) Move the joint to calibrate manually to approximate zero position, as shown in the dialog. After moving the joint click the <Next> button.

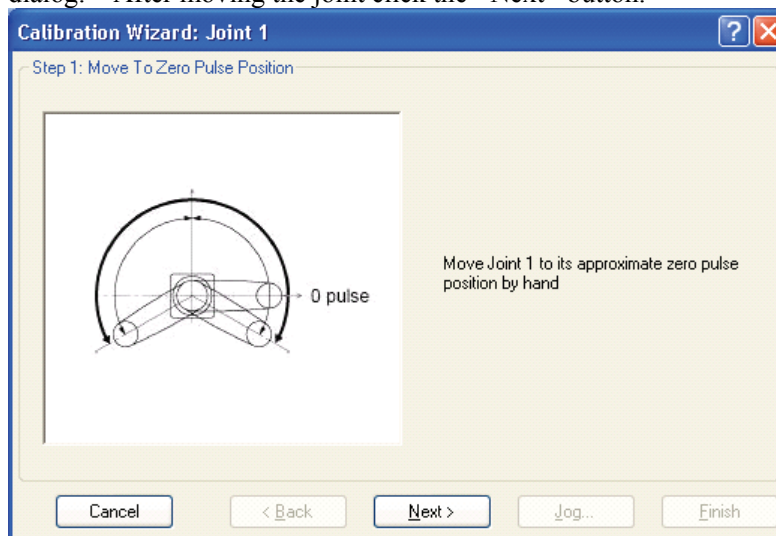

0 pulse position of Joint #1:  
position aligned with X-axis in  
Robot coordinate system

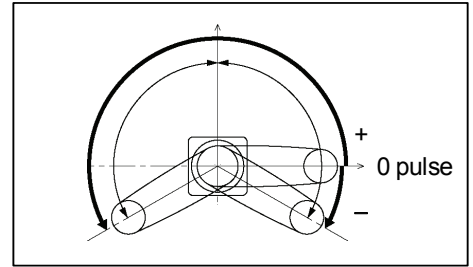

0 pulse position of Joint #2:  
position where Arms #1 and #2  
are in a straight line  
(Regardless of the Joint #1  
direction.)

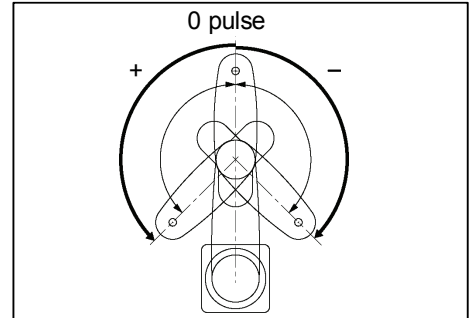

0 pulse position of Joint #3:  
upper limit position in motion  
range

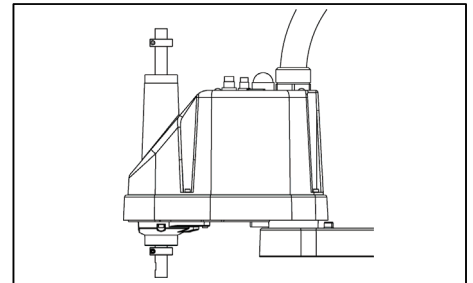

The height of Joint #3 depends on manipulator model.

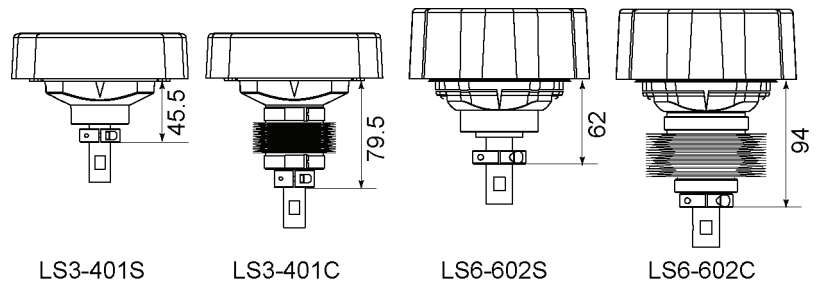

0 pulse position of Joint #4:  
position where the flat surface  
(or groove in the up/down  
mechanical stop) on the shaft  
faces toward the tip of Arm #2

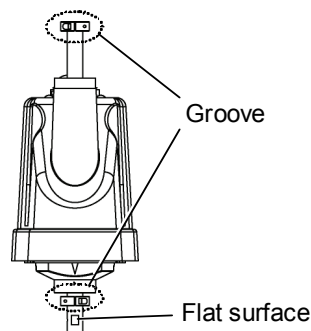
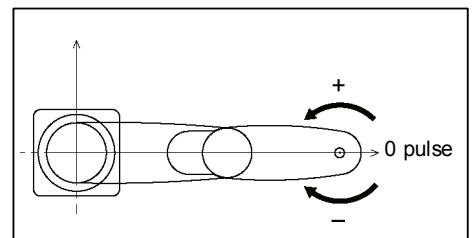

- (4) Click the <Yes> button to reset the encoder.

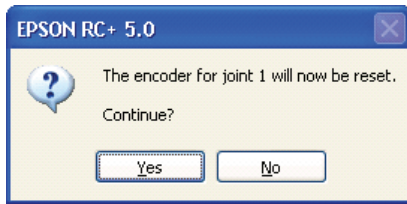

\* This window will disappear when the Controller starts up.

- (5) Reboot the Controller.

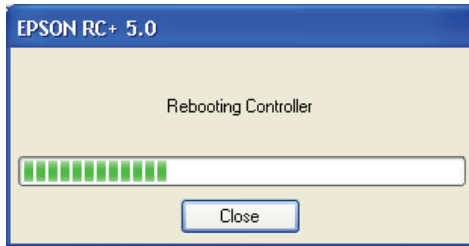

\* This window will disappear when the Controller starts up.

- (6) Select the reference point to use for calibration, and click the <Next> button.

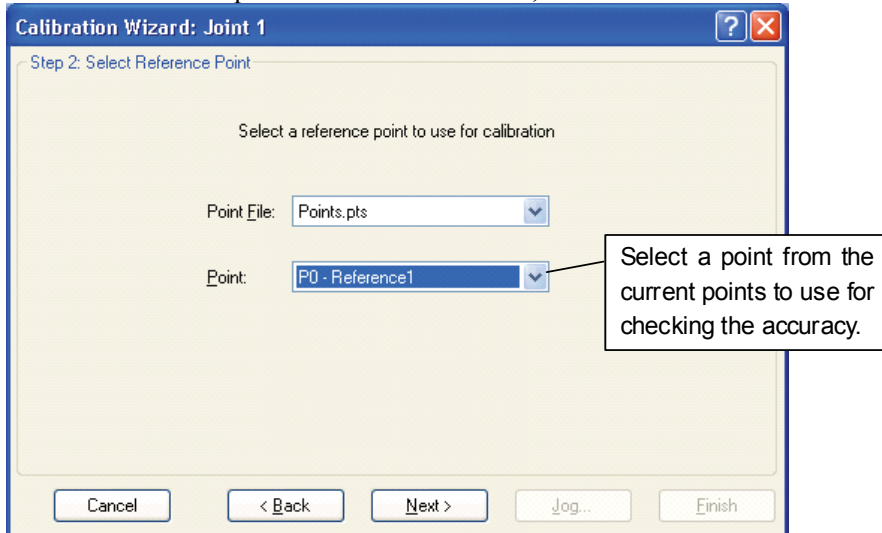

- (7) Click the <Jog...> button to display the [Jog & Teach] dialog.

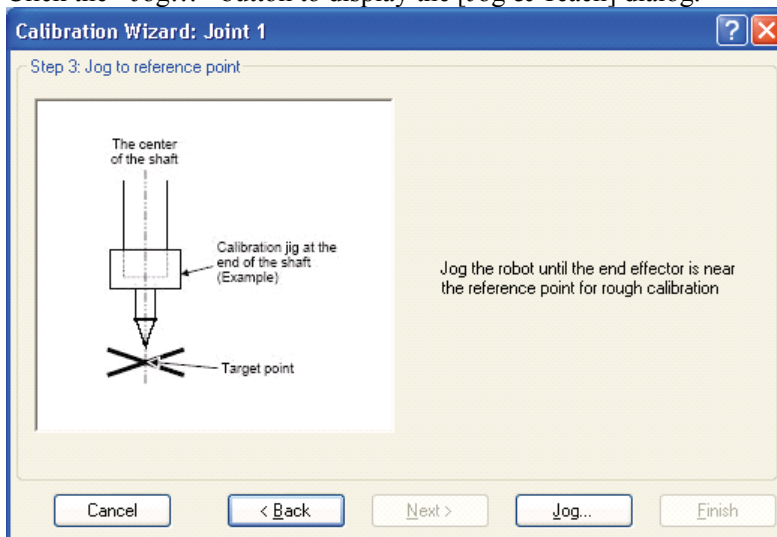

- (8) Jog the end effector to approximate reference point in the [Jog & Teach] dialog for rough calibration. Then click the <OK> button.

\* Before operating the robot, open the [Jog & Teach] tab and click on the <Motor ON> button.

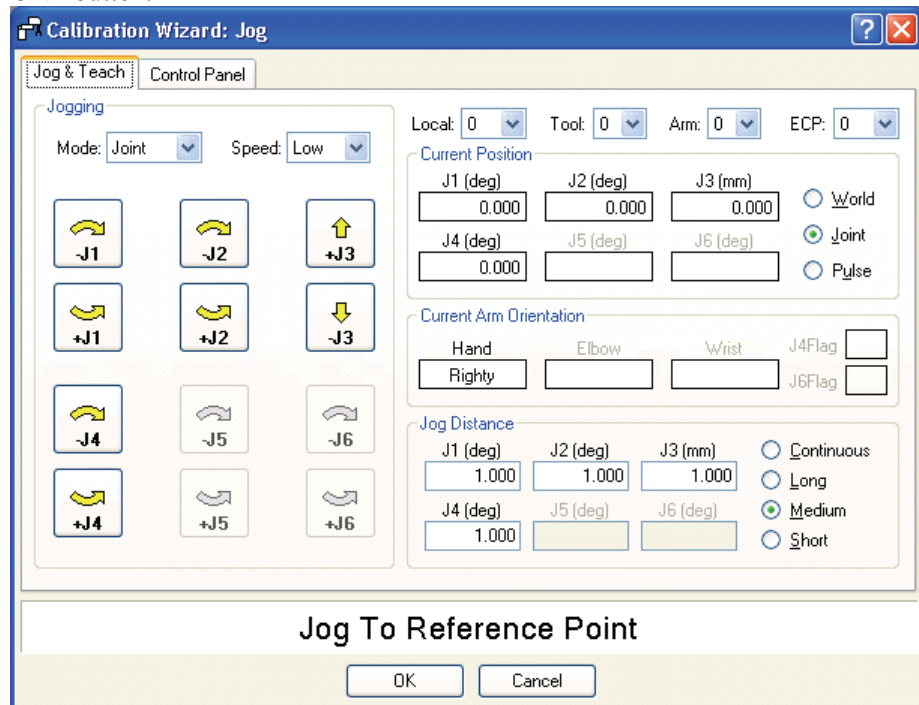

- (9) Click the <Next> button.

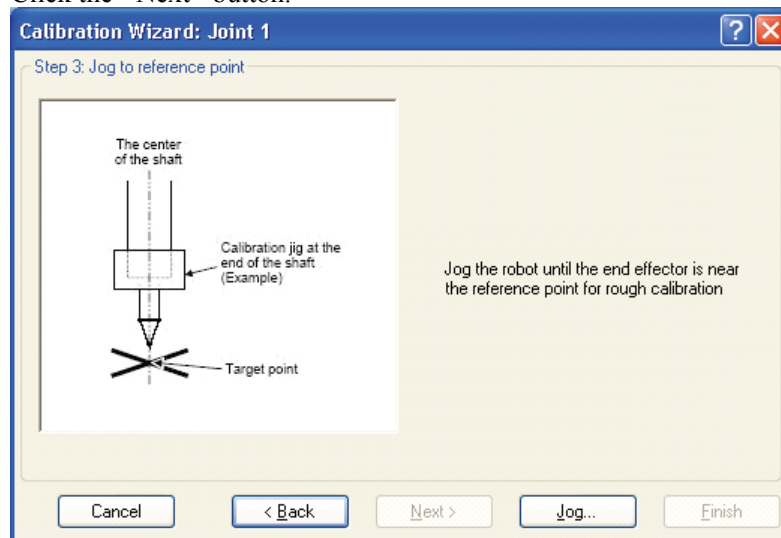

(10) The manipulator moves to the reference point. Click the <Execute> button.

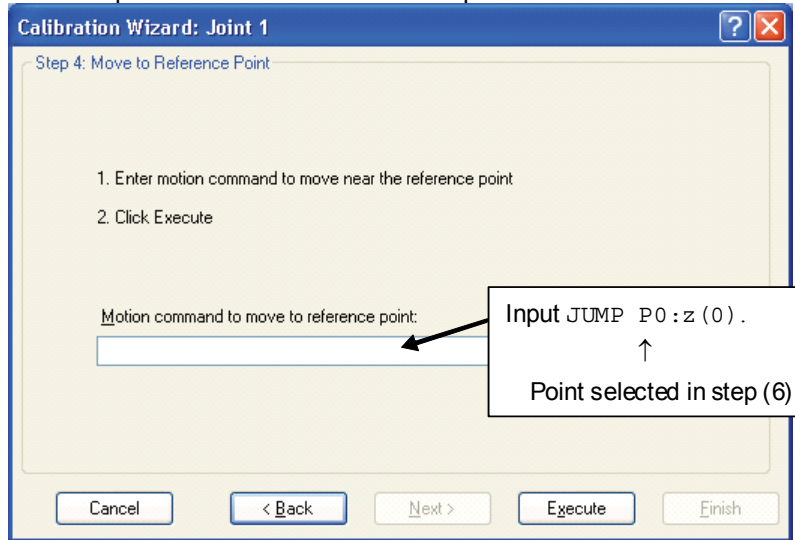

(11) Confirm the message and click the <Yes> button.

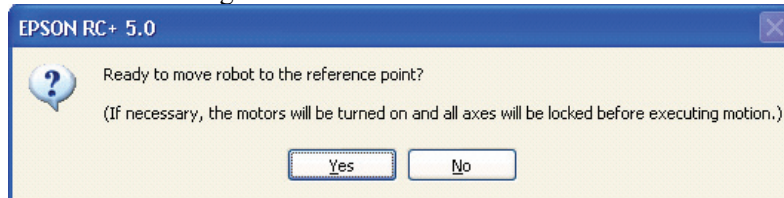

(12) After the manipulator moves to the reference point, click the <Next> button.

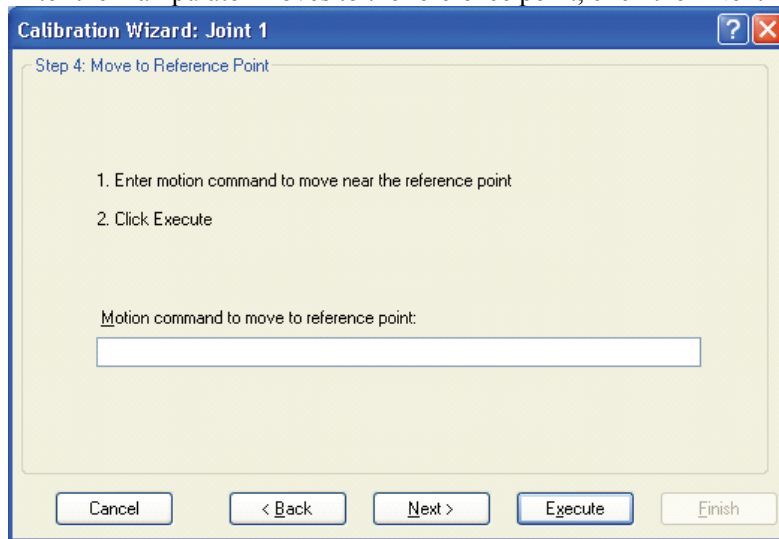

(13) Jog to the accurate reference position.

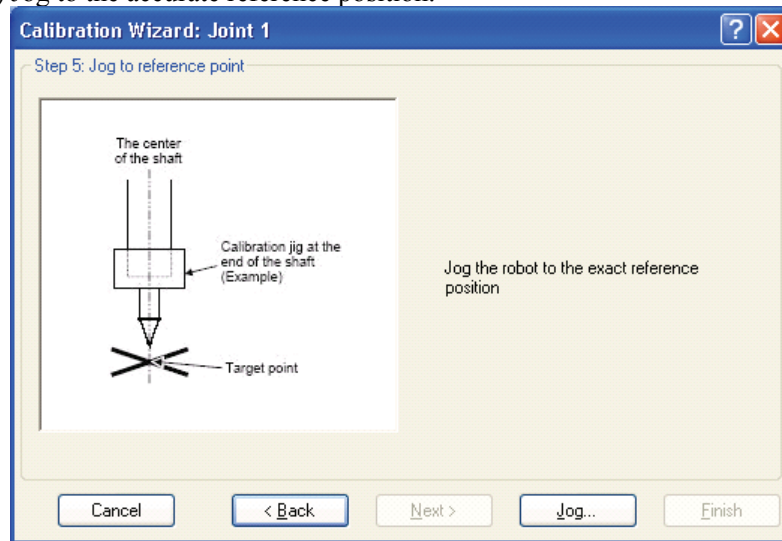

(14) Jog the end effector to approximate reference point in the [Jog & Teach] dialog for rough calibration. Then click the <OK> button.

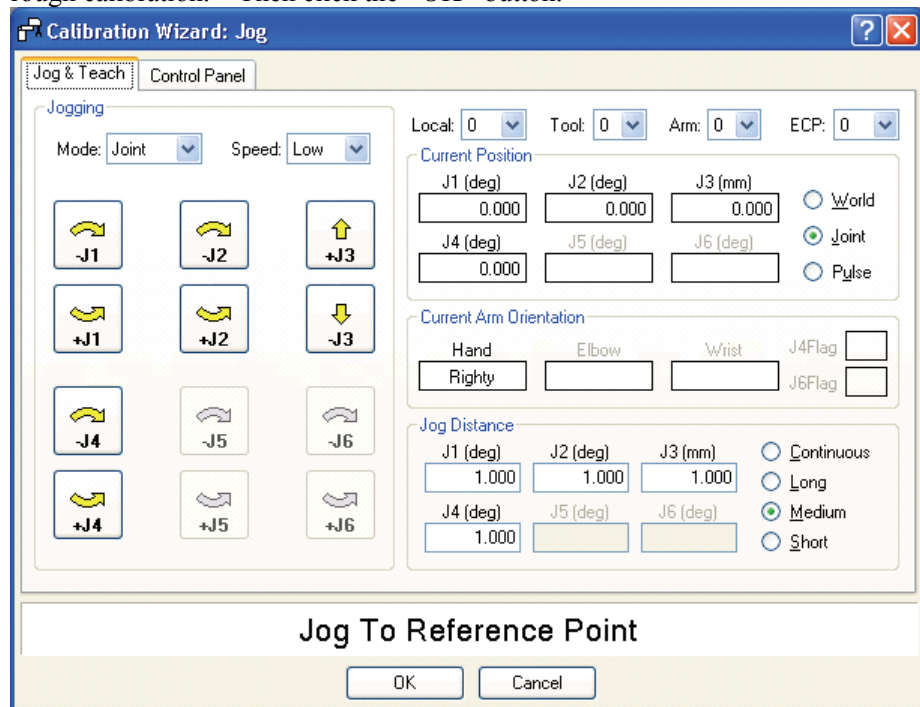

\* Position Joint #2 only and move Joint #3 to around 0 pulse.

(15) Click the <Next> button.

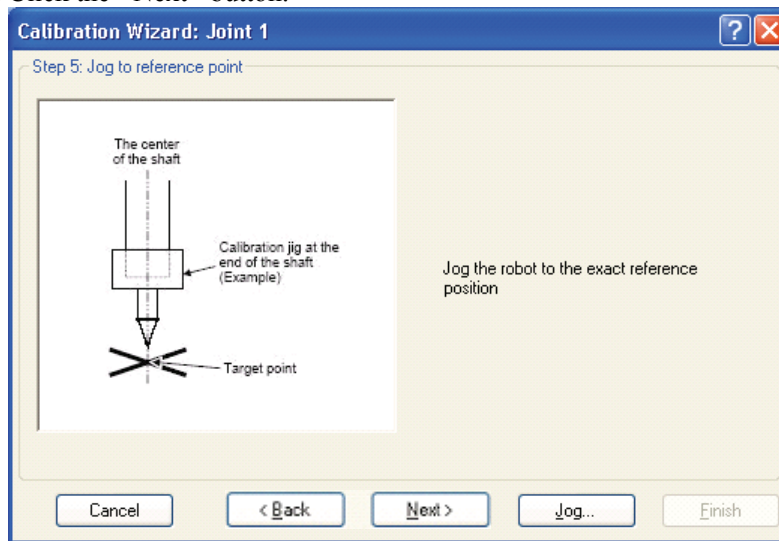

(16) Execute the procedure in “Calibration Using Right / Left Arm Orientations” to accurately calibrate Joint #2.

Go on to the step (17) for the other joints calibration.

i. Move to another point that has different pose (from righty to lefty) using Jump command. Click the <Yes> button.

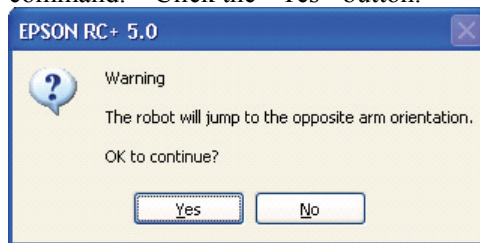

ii. Jog to the accurate reference position.

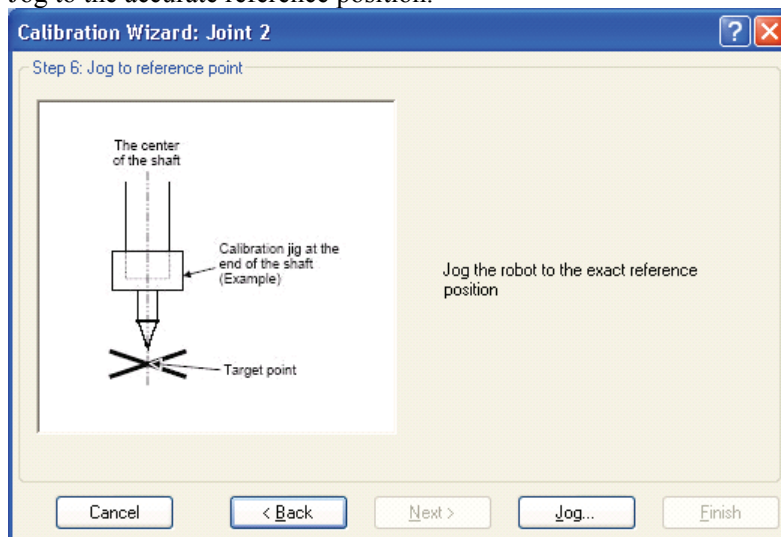



iii. Jog to the accurate reference position and adjust the position. Click the <OK> button.

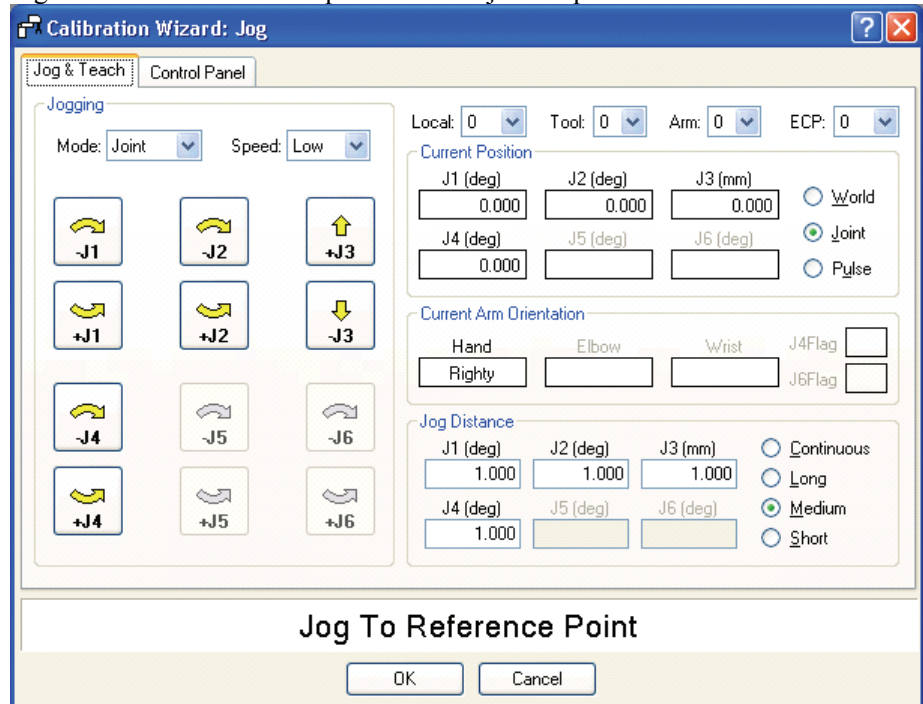

iv. Click the <Next> button.

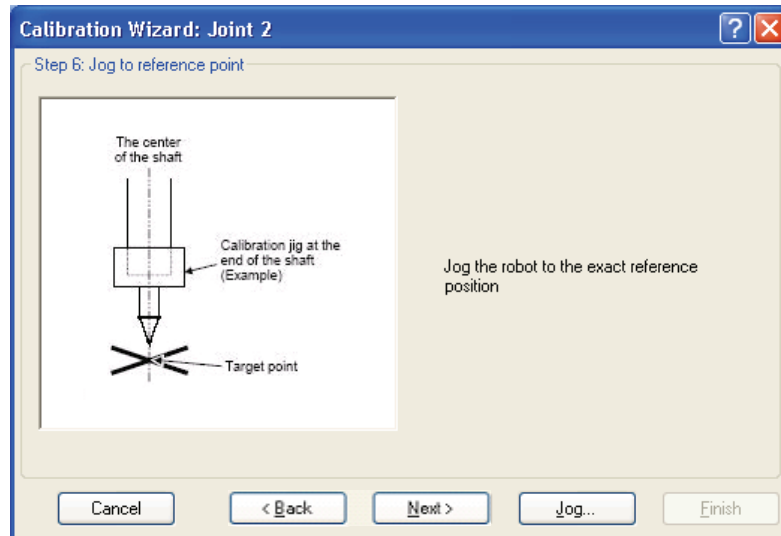

(17) Calibration is complete. Click the <Finish> button.

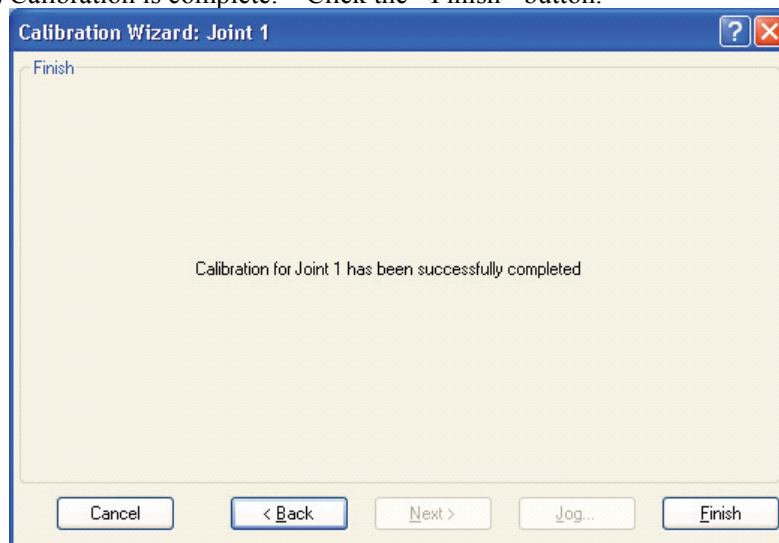

(18) Move the manipulator to other points and check if it can move without problems.  
Teach points where appropriate.

## 13.3 Accurate Calibration of Joint #2

When coordinates for the Manipulator working point require calculation, it is important for Joint #2 to be calibrated accurately.



If the accuracy of Joint #2 is not obtained through the steps in the section *13.2 Calibration Procedure*, follow the steps below “Calibration Using Right / Left Arm Orientations” to accurately calibrate Joint #2.

The reference point is the center of the ball screw spline shaft during this calibration.

When there is a misalignment between the center of the end effector and the center of the ball screw spline shaft, remove the end effector and execute the calibration of the shaft.

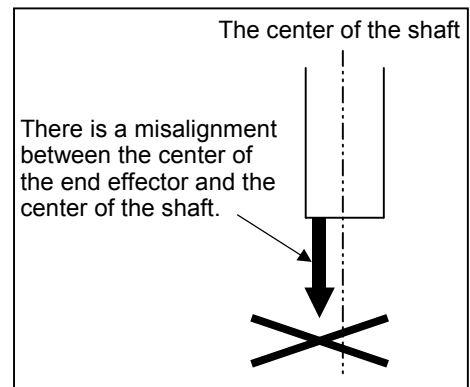

Make a calibration jig as shown in the right figure and attach it on the end of the shaft to make the center of the shaft clear.

Decide a target point and mark a cross (×) on it so that you can easily verify the center of the shaft after switching the arm pose between right and left.

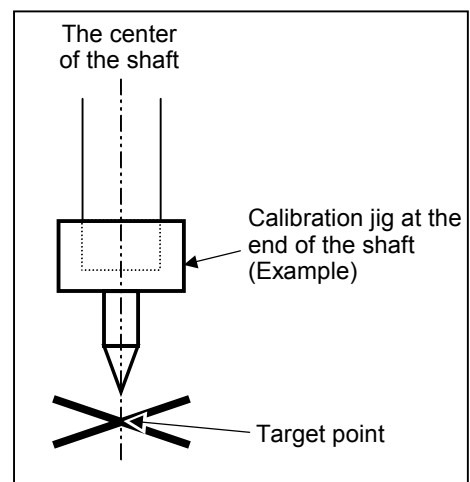

After removing the end effector and executing the calibration, install the end effector and move the Manipulator to the teaching point to verify whether there is a positional gap. If there is a positional gap, fine-tune the installation position of the end effector and teach the point again.

Coordinates for the working point requires calculation in the following cases:

- Teaching the working point by entering the coordinate values (MDI teaching)
- Switching the arm orientation between right and left at a given point
- Using the Pallet command
- Executing CP control (such as linear or circular interpolation)
- Using the Local command
- Pose data specified with relative coordinates <Example: P1+X(100)>
- Vision Guide camera calibrations

## Calibration Using Right / Left Arm Orientations

- (1) Check the point data for calibration

Use a point you can easily verify the accuracy within the work envelop of both right and left arm. Then, check the number of points you want to use.

- (2) Open the Tools menu | Robot Manager | Control Panel and click the MOTOR ON.
- (3) Click the <Free All> button to free all joints from servo control. Now, you can move arms by hands.
- (4) Move the arms to the position of point data for calibration in rightly arm orientation.
- (5) From the current position, teach any point data number unused.  
This point is now called P1.

Specify the point number “1” and click the <Teach> button in the [Jog & Teach].

- (6) Click the Lock All in the [Control Panel] to lock all joints under servo control.
- (7) Switch to the lefty arm orientation. Then, move the arm to the same point.

>Jump P1/L:Z(0) ' Change the arm orientation from righty to lefty  
Z is the maximum position

\* If there is interference on the way from right to lefty, click the Free All in the [Control Panel] and change the arm orientation to lefty by hands. Then, go to the step (6), (7).

- (8) The joints are slightly out of position.

Adjust the gap with the -Z in the Jogging group in the [Jog & Teach]. Then, teach another point data number unused. This point is now called P2.

Specify point number “P2” and click the <Teach> button in [Jog & Teach].

- (9) Input the new Hof's value.

>Hofs Hof's (1), Hof's (2) + (Ppls(P1,2) + Ppls(P2,2)) /  
2, Hof's (3), Hof's (4)

- (10) From the current lefty arm orientation (the position in the step (8)), teach the point data number used in the step (8). This point is called P2.

Specify point number “P2” and click the <Teach> button in [Jog & Teach].

- (11) Switch to the righty arm orientation. Then, make sure the manipulator move to the correct position.

>Jump P2/R ' Change the arm orientation from lefty to righty

\* If there is any interference on the way from lefty to righty, click the Free All in the [Control Panel] and change the arm orientation to righty by hands. Then, go to the step (6), (11).

- (12) Move the manipulator to other point data and make sure it moves to the correct position. Teach some more points if required.

\* Delete the two points taught for the Joint #2 calibration.

## 13.4 Calibration Procedure without using Calibration Wizard



This section indicates the calibration without using the calibration wizard of EPSON RC+. For details of calibration using the calibration wizard, refer to *13.2 Calibration Procedure*.

When coordinates for the Manipulator working point require calculation, it is important for Joint #2 to be calibrated accurately. Execute the procedure in “Calibration Using Right / Left Arm Orientations” to accurately calibrate Joint #2. For details, refer to *Maintenance: 13.3 Accurate Calibration of Joint #2*.

You cannot calibrate Joint #4 alone because of the structure of the Manipulator. When calibrating Joint #4, you must calibrate Joint #3 and #4 at the same time.



The reference point (a point to identify the position of the manipulator) needs to be specified for calibration.

Follow steps 1 to 6 described below in order to calibrate the origin.

### 1. Basic Pose Confirmation

(1)-1 After the part replacement, execute the calibration using the point data currently registered.

Confirm the point data number (P\*) to reconstruct the correct manipulator position.

\* Point data before the parts replacement (motor, reduction gear, belt, etc.) is necessary for the calibration.

### 2. Part Replacement

(2)-1 Replace parts as dictated by this manual.

\* Be careful not to injure yourself or damage parts during part replacement.

### 3. Encoder Initialization

(3)-1 Turn ON the Controller when all joints are in the motion range.

(3)-2 Manually move the joint that needs origin alignment to its approximate 0 pulse position.

0 pulse position of Joint #1:  
 position aligned with X-axis in  
 Robot coordinate system

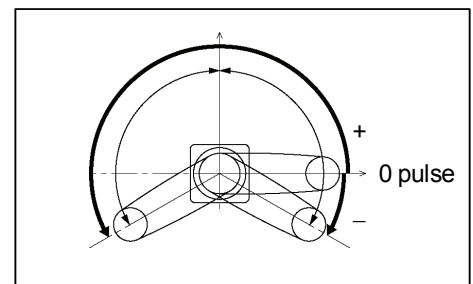

0 pulse position of Joint #2:  
 position where Arms #1 and #2 are in a straight line  
 (Regardless of the Joint #1 direction.)

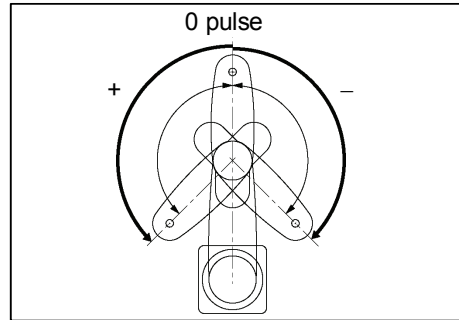

0 pulse position of Joint #3:  
 upper limit position in motion range

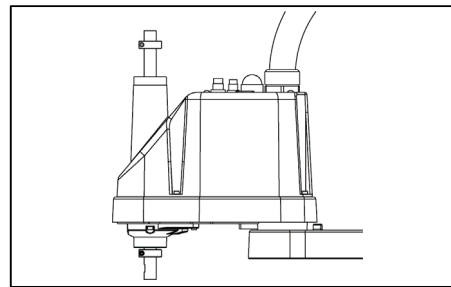

The height of Joint #3 depends on manipulator model.

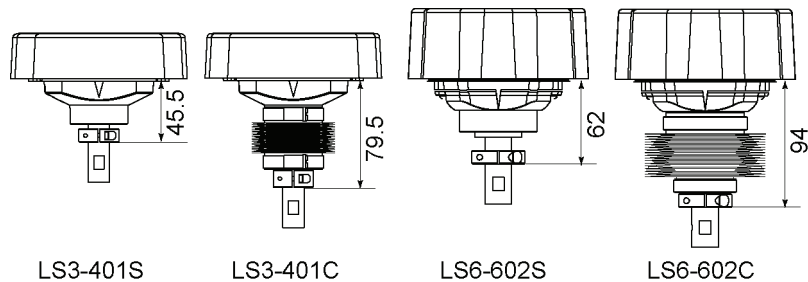

0 pulse position of Joint #4:  
 position where the flat surface  
 (or groove in the up/down  
 mechanical stop) on the shaft  
 faces toward the tip of Arm #2

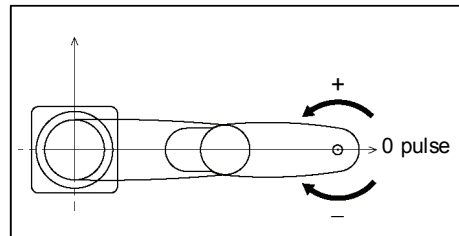
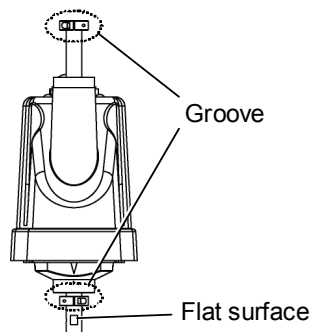

(3)-3 Connect EPSON RC+ to the Controller.

Select a robot to be calibrated. Input as below in the [Command Window] and execute it.

(This example uses “robot 1”.)

> robot 1

- (3)-4 Execute the absolute encoder initialization command.

Input one of the following commands to [Command Window] according to the joint being calibrated.

Joint #1: >EncReset 1  
 Joint #2: >EncReset 2  
 Joint #3: >EncReset 3  
 Joint #4: >EncReset 3, 4

- (3)-5 Reboot the Controller.

Select EPSON RC+ menu-[Tools]-[Controller] and click the <Reset Controller> button.

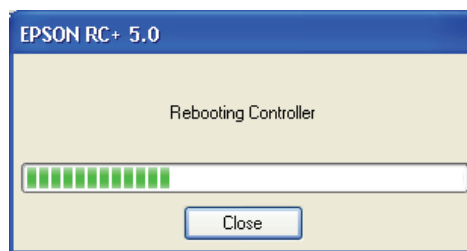

\* This window will be disappeared when the Controller starts up.

#### 4. Rough Calibration

- (4)-1 Turn ON the motor from EPSON RC+ menu-[Tools]-[Robot Manager]-[Controller Panel].

- (4)-2 Click the <Free All> button in the [Control Panel] page to free all joints and move the arms manually.

- (4)-3 Move the Manipulator to the approximate position and orientation.

- (4)-4 To execute temporary calibration, input the pulse value of the specified point data.

When the specified point data is “P1,” input and execute the following command to [Command Window] according to the joint being calibrated.

> Calpls Ppls (P1, 1) , Ppls (P1, 2) , Ppls (P1, 3) , Ppls (P1, 4)

- (4)-5 Execute the temporary calibration.

Input and execute one of the following commands to [Command Window] according to the joint being calibrated.

Joint #1: >Calib 1  
 Joint #2: >Calib 2  
 Joint #3: >Calib 3  
 Joint #4: >Calib 3, 4

## 5. Calibration (Accurate Positioning)

(5)-1 Click the <Lock All> button in [Control Panel] to put all joints back under servo control.

(5)-2 Move the joint to the specified point using a motion command.

For example, when the specified point data is “P1”, click <MOTOR ON> button in [Control Panel] and execute “Jump P1:Z(0)” from [Jog & Teach].

\* The joint NOT being calibrated moves to the original position.

(5)-3 Accurately align the joint\* being calibrated to the specified point using jog commands.

\* You must move Joint #3 and #4 to the position when calibrating Joint #4.

Select the jog mode [Joint] from [Jog & Teach] to execute the jog motion.

(5)-4 Execute the calibration.

Input and execute one of the following commands to [Command Window] according to the joint being calibrated.

```
Joint #1: >Calib 1  
Joint #2: >Calib 2  
Joint #3: >Calib 3  
Joint #4: >Calib 3, 4
```

## 6. Accuracy Testing

(6)-1 Move the Manipulator to another point to confirm that it moves to the same position.

If it does not move to the same position, re-calibrate using another point. You must set the point again if reproducibility cannot be assured through calibration.



## 14. Maintenance Parts List

### 14.1 LS3-401\*

Part Name		Code	Note	Reference: Maintenance
Cable Unit		R13B020059		4.1
AC Servo Motor	Joint #1	R13B000102	200 W	5.1, 6.1
	Joint #2 / #3 / #4	R13B000101	100 W	7.1, 8.1
Reduction Gear Unit *1	Joint #1	R13B010039	SHF20-50	5.2
	Joint #2	R13B010040	SHF17-50	6.2
O-ring	Joint #1	R13A030700200		5.2
		R13A031200700		
		R13B031245		
	Joint #2	R13A030700100		6.2
		R13A031200600		
Timing Belt	Joint #3	R13B030233	Z	7.2
	Joint #4	R13B030234	U1	8.2
		R13B030235	U2	
Solenoid Brake		R13B030509	Z	7.3
Brake Release Switch		R13Z702640100		-
Bellows	LS3-401C	R13B030704		9
Ball Screw Spline	LS3-401S	R13B010228	150 mm	10.2
	LS3-401C	R13B010229	120 mm	
Battery		R13B060007	Lithium battery for replacement (A set of 3 batteries)	11.1
Resolver Board		R13B040501		11.2
Control Board		R13B040502		11.3
LED Lamp		R13A030000200		12
Grease	Ball Screw Spline	R13ZA00330200	AFB grease (400 g)	10
	Reduction Gear Unit	R13ZA00330100	SK-1A (500 g)	5.2, 6.2
		R13ZA00330400	SK-2 (500 g)	
Arm Cover		R13B030448	White	3.1
M/C Cable		R12B020453	3 m	4.3
		R12B020454	5 m	
		R12B020455	10 m	

## 14.2 LS6-602\*

Part Name		Code	Note	Reference: Maintenance
Cable Unit		R13B020060		4.1
AC Servo Motor	Joint #1 / #2	R13B000102	200 W	5.1, 6.1
	Joint #3 / #4	R13B000101	100 W	7.1, 8.1
Reduction Gear Unit *1	Joint #1	R13B010041	SHF25-80	5.2
	Joint #2	R13B010039	SHF20-50	6.2
O-ring	Joint #1	R13A030700300		5.2
		R13A031200600		
		R13B031245		
		R13B031242		
	Joint #2	R13A030700200		6.2
		R13A031200700		
Timing Belt	Joint #3	R13B030236	Z	7.2
	Joint #4	R13B030237	U1	8.2
		R13B030238	U2	
Solenoid Brake		R13B030509	Z	7.3
		R13B030502	U	7.4
Brake Release Switch		R13Z702640100		-
Bellows	LS6-602C	R13B030708		9
Ball Screw Spline	LS6-602S	R13B010231	200 mm	10.2
	LS6-602C	R13B010232	170 mm	
Battery		R13B060007	Lithium battery for replacement (A set of 3 batteries)	11.1
Resolver Board		R13B040501		11.2
Control Board		R13B040502		11.3
LED Lamp		R13A030000200		12
Grease	Ball Screw Spline	R13ZA00330200	AFB grease (400 g)	10
	Reduction Gear Unit	R13ZA00330100	SK-1A (500 g)	5.2, 6.2
Arm Cover		R13B030449	White	3.1
M/C Cable		R12B020453	3 m	4.3
		R12B020454	5 m	
		R12B020455	10 m	

**\*1 Reduction Gear Unit**

A reduction gear unit consists of the following three parts. When replacing the reduction gear unit, be sure to always replace the waveform generator, flexspline, and circular spline all together as one set.

**Waveform generator**

This waveform generator consists of an ellipsoidal cam with ball bearings on its outer circumference.

The inner ring of bearings is secured to the cam, while the outer ring is capable of flexible deformation through the ball bearings.

**Flexspline**

A thin, elastic, cup-shaped metal body with gear teeth around the outer circumference of the opening.

**Circular spline**

A rigid, ring-shaped body with gear teeth on the inner circumference.

The circular spline has two more teeth than the flexspline does.

Splines are greased. Be careful not to let grease adhere to clothes.

